

Crestron CLT-1DELV4/CLX-1DELV4

Terminal Block and Module

Installation Guide



Further Inquiries
To locate specific information or resolve questions after reviewing this guide, contact Crestron's True Blue Support at 1-888-CRESTRON [1-888-273-7876] or, for assistance within a particular geographic region, refer to the listing of Crestron worldwide offices at www.crestron.com/offices.

To post a question about Crestron products, log onto Crestron's Online Help at www.crestron.com/onlinehelp. First-time users must establish a user account to fully benefit from all available features.

Future Updates
As Crestron improves functions, adds new features, and extends the capabilities of the CLT-1DELV4 and CLX-1DELV4, additional information may be made available as manual updates. These updates are solely electronic and serve as intermediary supplements prior to the release of a complete technical documentation revision.

Check the Crestron website periodically for manual update availability and its relevance. Updates are identified as an "Addendum" in the Download column.

WARNING: To avoid fire, shock, or death, turn off power at circuit breaker or fuse and test that power is off before wiring!

- NOTES:** Observe the following points.
- To be installed and/or used in accordance with appropriate electrical codes and regulations.
 - This product should be installed by a qualified electrician.

Crestron Electronics, Inc.
15 Volvo Drive Rockleigh, NJ 07647
Tel: 888.CRESTRON
Fax: 201.767.7576
www.crestron.com

Installation Guide - DOC. 5989C (2002071) 12.14



Specifications subject to change without notice.

This product is Listed to applicable UL Standards and requirements by Underwriters Laboratories Inc.



INTRODUCTION

The Crestron® 1-feed, 4-dimmer terminal block and module (CLT-1DELV4 and CLX-1DELV4) are considered a single entity and must be used together. They ship separately so that the terminal block (CLT-1DELV4) wiring can be accomplished before module (CLX-1DELV4) installation. They can be mounted in any Crestron Automation Enclosure (CAEN-Series Enclosures). The terminal block is designed to terminate the circuit feed (line and neutral) and distribute the controlled circuit (load) to the fixtures. The module connects to the terminal block and performs dimming control of the lighting loads.

The unit requires 120 Vac 50/60 Hz single phase input voltage. The maximum load is 10 A for any controlled circuit; the maximum load is 16 A total.

An oversized heat sink dissipates heat efficiently. There are LEDs on the module to indicate communication to a Cresnet® network, input power to the module, and output power to the load.

The CLT terminals and CLX modules are shown in the following illustrations.

CLT-1DELV4 Terminal Block with Left- and Right-Side Labels

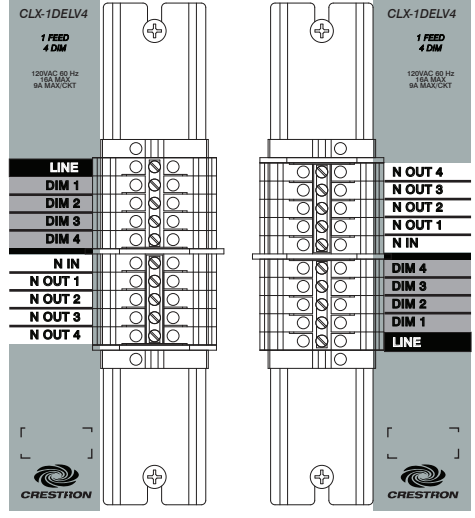

CLX-1DELV4 Module (Connects to a CLT-1DELV4)

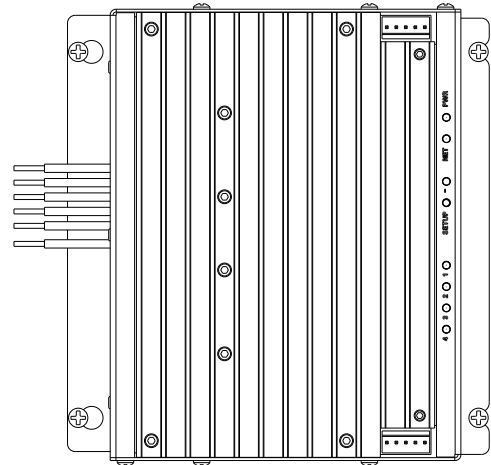

INSTALLATION

NOTE: Before using the CLX-1DELV4, ensure the device is using the latest firmware. Check for the latest firmware for the CLX-1DELV4 at www.crestron.com/firmware. Firmware is loaded onto the device using Crestron Toolbox™.

The terminal block and module must be mounted into a Crestron Automation Enclosure by a licensed electrician and in accordance with all national and local codes.

CAUTION: This equipment is for indoor use only and needs to be air-cooled. Mount it in a well-ventilated area. The ambient temperature must be 32° to 104° F (0° to 40° C). The relative humidity must be 0% to 90% (non-condensing).

NOTE: When connecting to an arc fault breaker, the load should not exceed 1,000 watts total. Crestron certified breakers have a 2,000 watt limit.

Terminal blocks are installed along the left side of single-wide enclosures and along the outside edges (left and right sides) of double-wide enclosures. Modules are installed along the right side of single-wide enclosures and side-by-side in the center of double-wide enclosures. When installing modules and terminal blocks in a double-wide enclosure, be sure to invert the units on the right side so that they can be properly wired. Refer to the illustrations that follow when considering the location of terminal blocks and modules within an enclosure.

NOTE: Modules and terminal blocks must be installed into the lowest available spaces and continue toward the top of the enclosure.

IMPORTANT SAFEGUARDS

When using electrical equipment, basic safety precautions should always be followed including the following:

READ AND FOLLOW ALL SAFETY INSTRUCTIONS.

- Do not use outdoors.
- Do not mount near gas or electric heaters.
- Equipment should be mounted in locations and at heights where it will not be subjected to tampering by unauthorized personnel.
- The use of accessory equipment not recommended by the manufacturer may cause an unsafe condition.
- Do not use this equipment for other than its intended use.
- All servicing should be performed by qualified service personnel.
- If any Emergency Circuits are fed or controlled from this panel, it must be located electrically where fed from a UPS, generator, or other guaranteed source of power during emergency and power outage situations.

SAVE THESE INSTRUCTIONS.

Terminal Block and Module Layout for a Single-Wide Enclosure

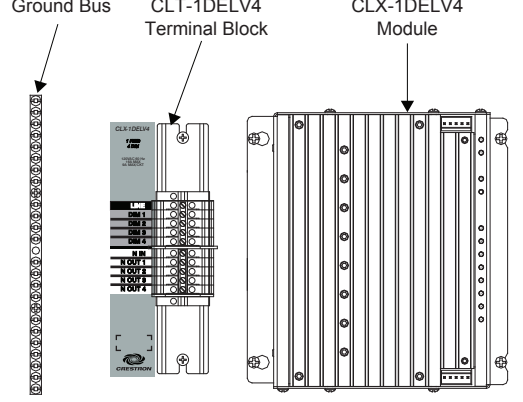

NOTE: Unless otherwise indicated, the lighting system specified in this guide is modular, requiring assembly in the field by a licensed electrician in accordance with all national and local codes.

If an assembled UL Listed panel is required, it can be obtained through Crestron's UL Listed panel shop. This includes complete in-factory system configuration and assembly by Crestron for an additional fee.

Terminal Block Installation and Field Wiring

Apply the supplied adhesive label before installing the terminal block. The adhesive label provides the labeling for each terminal in the terminal block and is designed to accommodate installation into the left or right side of a cabinet.

NOTE: Both left-side and right-side adhesive wiring labels are provided. The left-side labels are used in both single- and double-wide enclosures. The right-side labels are only used in double-wide enclosures.

- Remove the backing from the left- or right-side adhesive wiring label.
- Apply the adhesive label by aligning the holes in the label with the holes on the Crestron Automation Enclosure where the terminal block is to be mounted. The wiring label lies beneath the terminal block as shown in the following diagrams.
- Use the two supplied self-tapping Phillips pan head screws (8B x 1/4 inch length) to secure the terminal block to the Crestron Automation Enclosure.

CAUTION: Bypass jumpers are provided to test circuits and to protect the module during installation. When properly secured by five screws, each of the two jumpers on the black and red sections of the terminal block shorts the LINE in to DIM out so that the circuit is energized. Do not remove any bypass jumpers until all feed and load wiring has been completed, the circuit has been tested for electrical faults, and the module has been installed. Refer to "Module Installation."

Furthermore, the two jumpers on the white sections of the terminal block tie the neutral ins to the neutral outs. These jumpers should never be removed.

NOTE: Use copper conductors only – rated 75° C or greater.

- Turn off the circuit breakers.
- Connect the circuit feed (line and neutral) and controlled circuit (load) wires to the terminal block per the markings provided on the wiring label (as shown in the following diagrams). Terminal blocks accept one 14–10 AWG wire. Strip the wires to 1/2 inch (13 millimeters). Tighten terminal blocks to 9 in-lbs.
- Terminate the ground wires at the grounding terminal blocks that are available in the cabinet. Tighten the grounding terminal blocks to 35 in-lbs (14–10 AWG), 40 in-lbs (8 AWG), or 45 in-lbs (6–4 AWG).
- Test each circuit for electrical faults by turning on each of the circuit breakers and checking that the breakers do not trip and that power is delivered to the proper loads.

Wiring the Terminal Block to the Feed and Load(s)

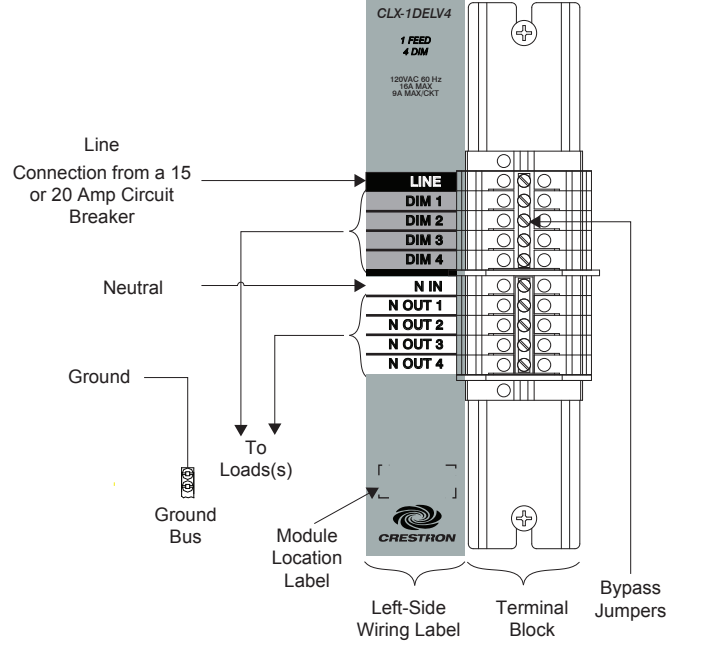

Module Installation

CAUTION: The module contains electrostatic sensitive devices (ESDs); the unit must be handled from the metal chassis – do not touch the PC board or components.

Install the modules after the terminal blocks are installed and the enclosure has been completely wired.

- Use the four supplied self-tapping Phillips pan head screws (8B x 1/4 inch length) to secure the module to the enclosure.
- As shown in the wiring diagram above, connect the wires from the module to the terminal block. Each wire exits the module directly in line with, and is the same color as, the terminal to which it should be connected. Wires are pre-stripped to 1/2 inch (13 millimeters). Tighten to 9 in-lbs.
- If the module is being installed above another module within the enclosure, attach the supplied module interconnect cable to the two modules. The illustration that follows shows the area within a double-wide enclosure where the corners of four modules meet.

NOTE: One wire on the module interconnect cable may be a different color from the rest. The color has no bearing on its orientation during installation.

Use Module Interconnect Cable to Wire One Module to Another

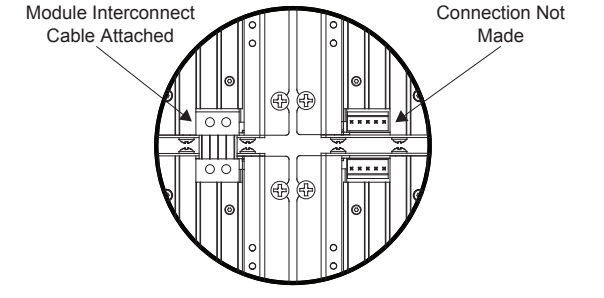

- Turn on the circuit breakers and verify that the green PWR LED on the module lights, the breakers do not trip, and power is delivered to the loads.
- Turn off the circuit breakers.

NOTE: Before the bypass jumpers are removed, the control system that provides functionality to the system should be properly connected and programmed.

- Remove the bypass jumpers on the black and red sections of the terminal block. The jumpers on the white sections of the terminal block must remain installed. Refer to the figures that follow for reference.

Wiring the Terminal Block to the Module

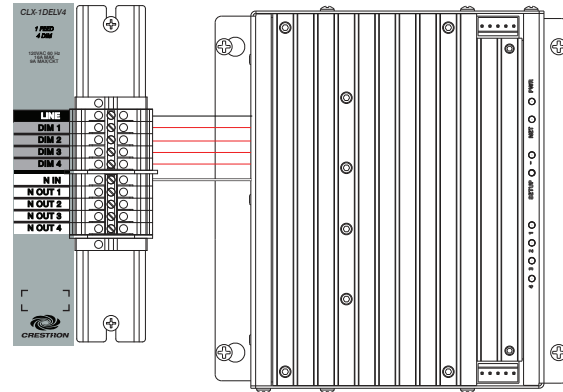

Remove the Line Jumpers after Testing

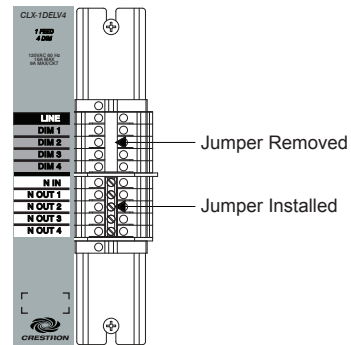

TEST THE LOADS

Test that each load is connected to the proper output on the module by using Local mode.

- Press the **SETUP** button momentarily (less than three seconds) to enter Local mode. The SETUP LED and output LED 1 illuminate and power is applied to the devices connected to output 1.
- Press the **SETUP** button again to turn off output 1 and turn on output 2.
- Press the **SETUP** button again for each output that needs to be tested.
- After turning on the last output, press the **SETUP** button again to turn on all outputs.
- Press the **SETUP** button once more to turn off all outputs and LEDs and to exit Local mode.

Product warranty can be found at www.crestron.com/warranty.

The specific patents that cover Crestron products are listed at patents.crestron.com.

Crestron, the Crestron logo, Crestron Toolbox, and Cresnet are either trademarks or registered trademarks of Crestron Electronics, Inc. in the United States and/or other countries. UL and the UL logo are either trademarks or registered trademarks of Underwriters Laboratories, Inc. in the United States and/or other countries. Other trademarks, registered trademarks and trade names may be used in this document to refer to either the entities claiming the marks and names or their products. Crestron disclaims any proprietary interest in the marks and names of others. *Crestron is not responsible for errors in typography or photography.*

This document was written by the Technical Publications department at Crestron.
©2014 Crestron Electronics, Inc.