

# Crestron **TMK-4L & WMKT-4L** Trim Ring Mount Kits

---

## Installation Guide



This document was prepared and written by the Technical Documentation department at:



Crestron Electronics, Inc.  
15 Volvo Drive  
Rockleigh, NJ 07647  
1-888-CRESTRON

# Contents

<b>Trim Ring Mount Kits: TMK-4L &amp; WMKT-4L</b>	<b>1</b>
Description.....	1
Setup.....	2
Supplied Hardware.....	2
Installation.....	4
Resources.....	10
Industry Compliance.....	10
Reference Documents.....	10
Further Inquiries.....	10
Future Updates.....	10
Return and Warranty Policies.....	11
Merchandise Returns / Repair Service.....	11
CRESTRON Limited Warranty.....	11



# Trim Ring Mount Kits: TMK-4L & WMKT-4L

---

## Description

Trim Ring Mount Kits are the preferred method of mounting the Crestron Isys<sup>®</sup> TPS-4L wall mounted touchpanel when a finished appearance within a neatly trimmed cutout is required. This application is perfect for wallpapering.

---

**NOTE:** If mounting into a material other than drywall (for example, wood lectern, concrete, or rock) use the cutout template, available in the post-construction kit WMKT-4L. For concrete and rock mounting material, allow for proper ventilation before mounting the touchpanel.

---

There are two Trim Ring Mount Kits. The TMK-4L is a pre-construction accessory. Pre-construction refers to framed walls prior to hanging drywall. This accessory must be used with either the Pre-Construction Mount Kit (PMK-4L) or Back Box Kit (BB-4L).

The WMKT-4L is a post-construction kit. Post-construction refers to framed walls with drywall hung. This accessory is designed with a mounting plate so that it can be placed anywhere on a wall without the support of a stud. The mounting plate is also ideal for installing the touchpanel in a lectern.

---

**NOTE:** If necessary, consult the latest revision of the TPS-4L Installation and Operations Guide (Doc. 6449) for a complete list of mounting options. The document is available from the Crestron website (<http://www.crestron.com/manuals>).

---

## Setup

### Supplied Hardware

The TMK-4L consists of a metal trim ring that attaches to the BB-4L or PMK-4L. The WMKT-4L consists of the trim ring found in the TMK-4L as well as a mounting plate.

The mounting plate provides the necessary support for post-construction applications. Two overlay cutout templates (4007975) are supplied. One is in the shape of the required opening; the other is similar to a frame, with the inner area of the frame the shape of the required opening. (Refer to the illustrations on pages 3 and 4.) Use the template that is most convenient.

#### *Supplied Hardware for the TMK-4L and WMKT-4L*

DESCRIPTION	PART NUMBER	QUANTITY
Metal, Plate, Trim Ring	2013241	1
Metal, Plate, Mounting (WMKT-4L only)	2013242	1
Screw, #04-40 x 2", Pan, Phil (WMKT-4L Only)	2018793	4
Overlay, Template, Wall Cutout (WMKT-4L Only)	4007975	1

The dimensions of the TMK-4L/WMKT-4L are shown below and on the next page.

#### *Dimensional Drawing – Trim Ring*

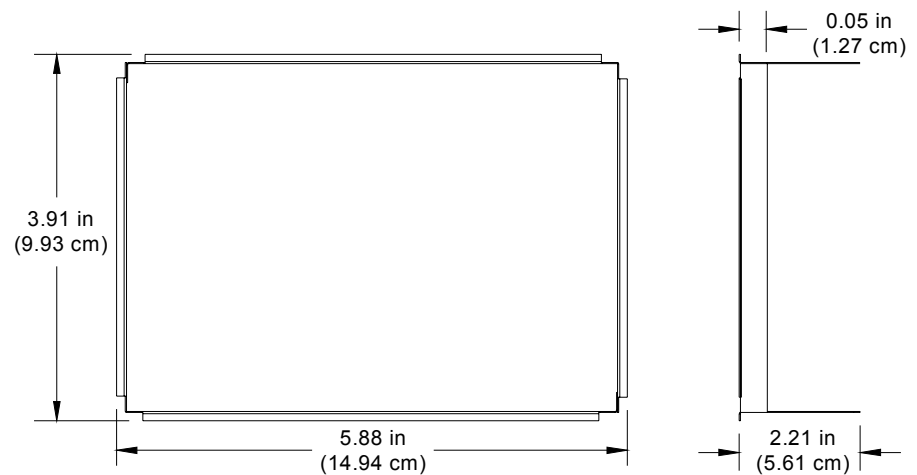

*Dimensional Drawing – Mounting Plate*

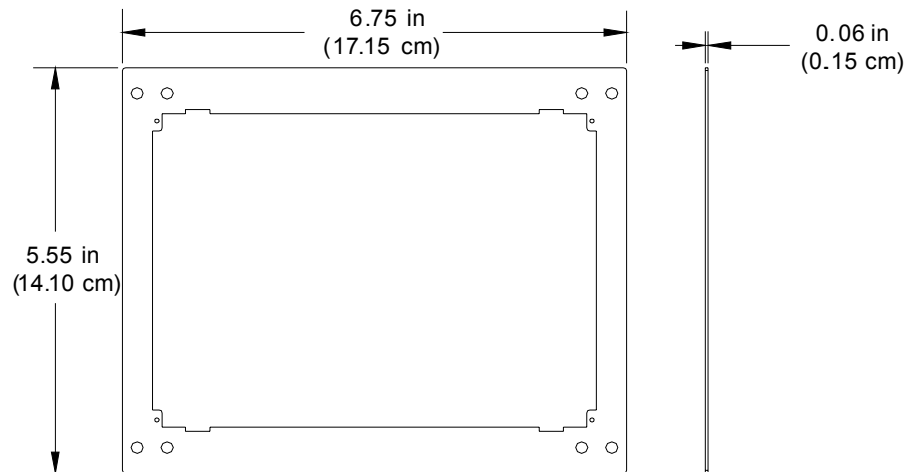

*Drywall Cutout Template and Dimensions (supplied with WMKT-4L only), 1 of 2*

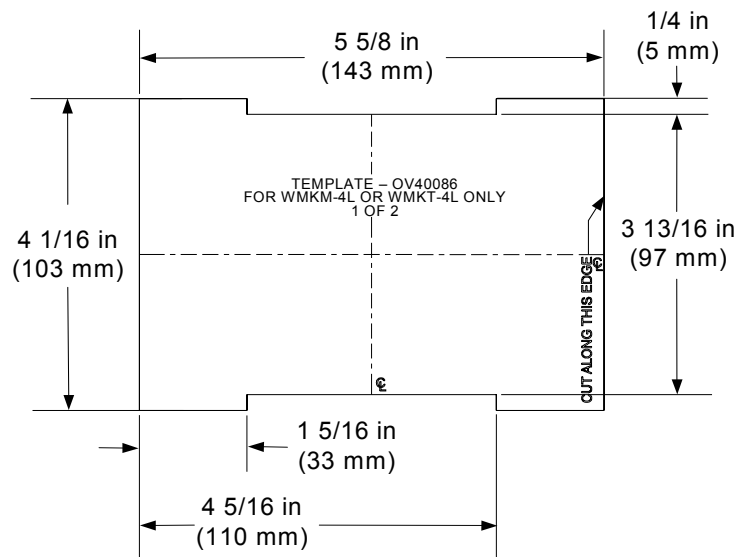

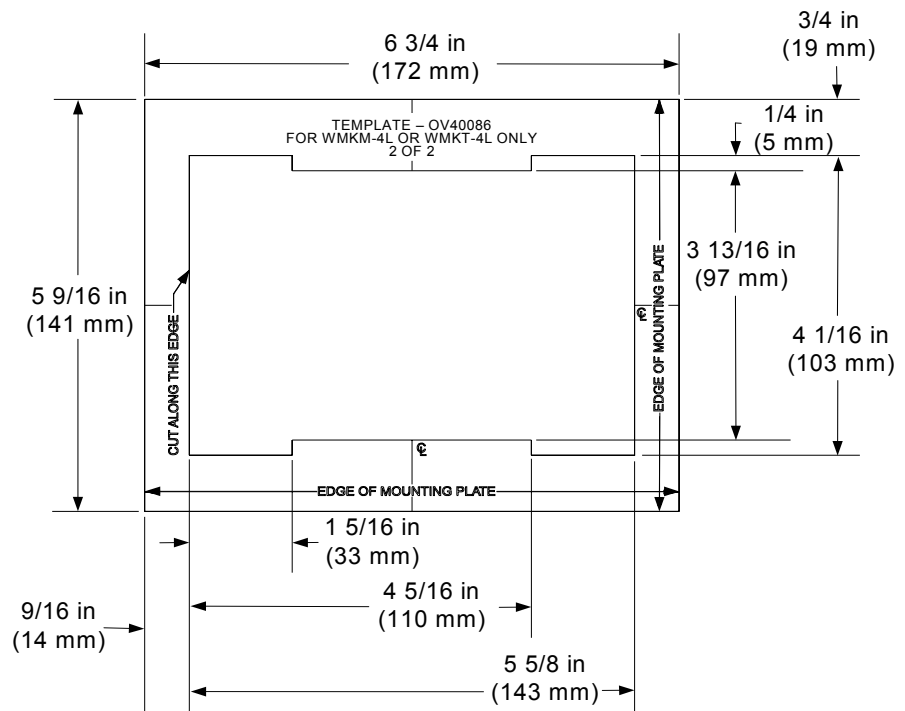
*Drywall Cutout Template and Dimensions (supplied with WMKT-4L only), 2 of 2*

## Installation

This section provides an installation procedure for each Trim Ring Mount Kit. The “TMK-4L Procedure” starts below and the “WMKT-4L Procedure” starts on page 6. Be sure to review each procedure before starting.

### **TMK-4L Procedure**

This section provides the necessary steps for the assembly of the TMK-4L with either the BB-4L or PMK-4L. It is assumed that the BB-4L or PMK-4L has been secured to the stud according to the instructions in the latest revisions of their Installation Guides (Doc. 6387 and Doc. 6388 respectively). It is also assumed that drywall is in place and a rectangular cutout for the touchpanel is made in the drywall.

Complete the steps in the order provided. The only tool required and not supplied is a level.

---

**CAUTION:** Allow an air gap of at least 12 inches (30.48 cm) in the wall cavity above and below the touchpanel for heat dissipation.

---

**NOTE:** When installing into the PMK-4L, verify that the 18 AWG bus wire securing the cables for the touchpanel remains attached.

---

1. Verify that the rectangular cutout in the drywall is as level as possible.
2. Insert the symmetrical trim ring into the opening, as shown in the illustration on the following page.

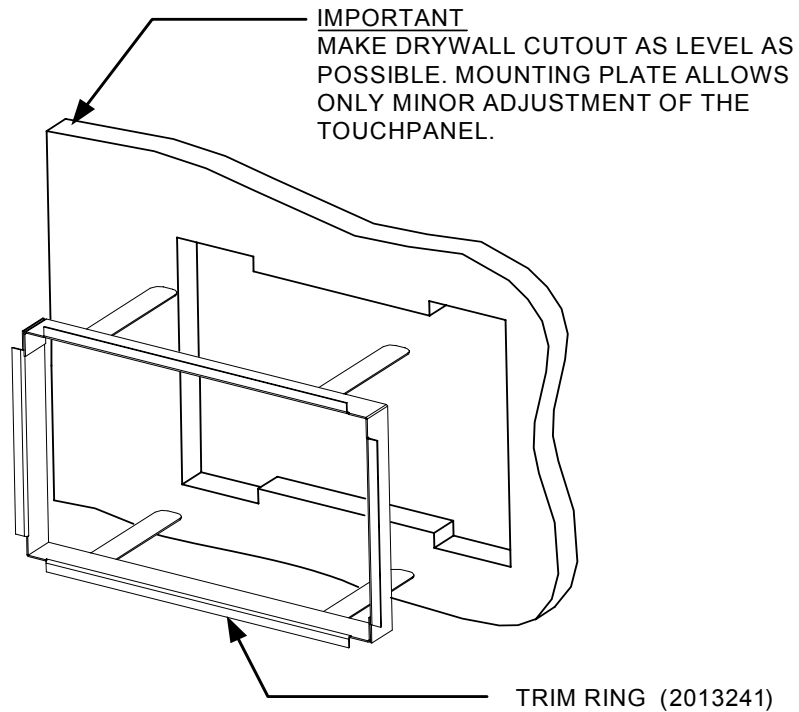

*Insert Trim Ring into Opening*

---

**NOTE:** The required PMK-4L or BB-4L is not shown.

---

3. When the trim ring is in position, bend the top two flanges of the ring upward and the bottom two flanges downward.
  - If mounting into the PMK-4L, bend the flanges approximately 90 degrees.
  - If mounting into the BB-4L, bend the flanges back as far as they can go.
4. Run the necessary cables for the touchpanel and secure them behind the drywall.
5. The TPS-4L can be installed using the four tapped holes in the PMK-4L or BB-4L. Refer to the latest revision of the TPS-4L Operations and Installation Guide (Doc. 6449) for details. Refer also to the comprehensive illustration on the following page.

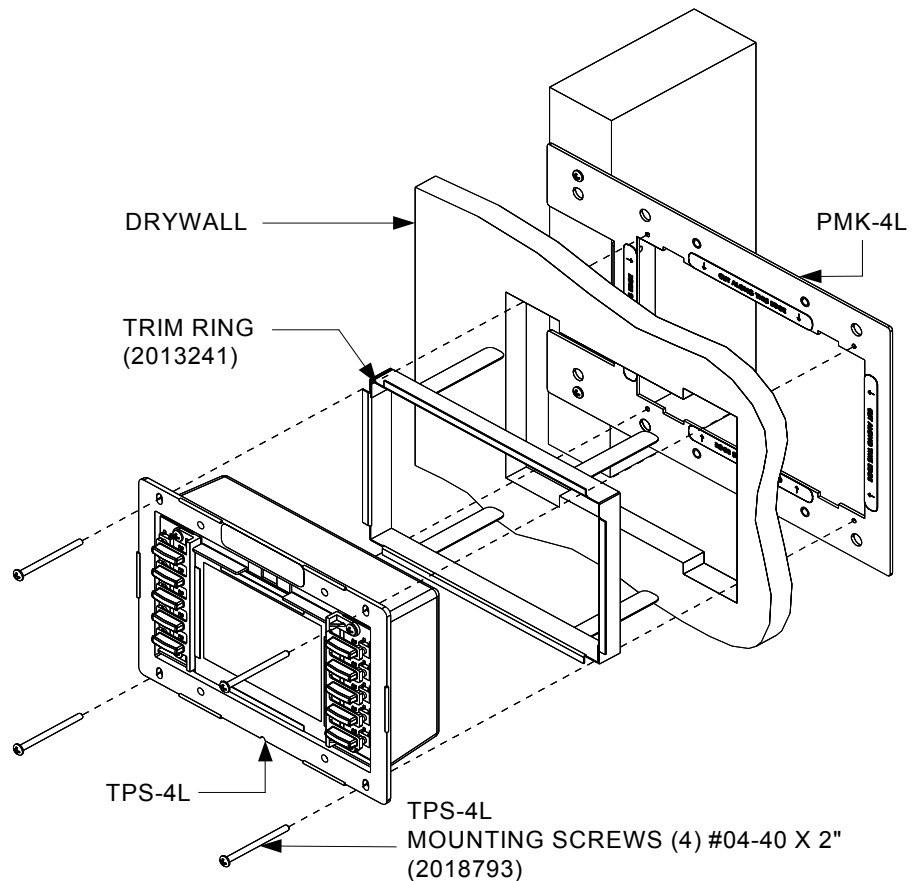
*Touchpanel Mounting Using TMK-4L – Exploded View***WMKT-4L Procedure**

This section provides the necessary steps for the assembly and installation of the WMKT-4L into a wall. Review the procedure and complete the steps in the order provided. The only tools or materials required and not supplied are a drywall saw or equivalent and a level.

---

**CAUTION:** Allow an air gap of at least 12 inches (30.48 cm) in the wall cavity above and below the touchpanel for heat dissipation.

---

1. Locate an area on the wall that is free of miscellaneous wiring and studs.
2. Make a small hole near the middle of the designated site; verify that the location is suitable.

---

**NOTE:** Make the cutout as level and smooth as possible. The mounting plate allows for only minor leveling adjustments. If a larger cutout is made accidentally, consider purchasing the Crestron Mud Mount Kit, MMK-4L. Together with the mounting plate supplied with the WMKT-4L, it provide a cost-effective means of correction. Essentially, the combination of these two kits makes up the Crestron Mud Mount Kit for the wall, WMKM-4L. Simply follow the “WMKM-4L Procedure” in the latest revision of the Mud Mount Kits Installation Guide (Doc. 6389).

---

3. Use the drywall saw or equivalent to produce a level, rectangular cutout in the drywall as shown on page 3 or 4.

4. Insert the trim ring into the opening, as shown in the following illustration.

***Insert Trim Ring into Opening***

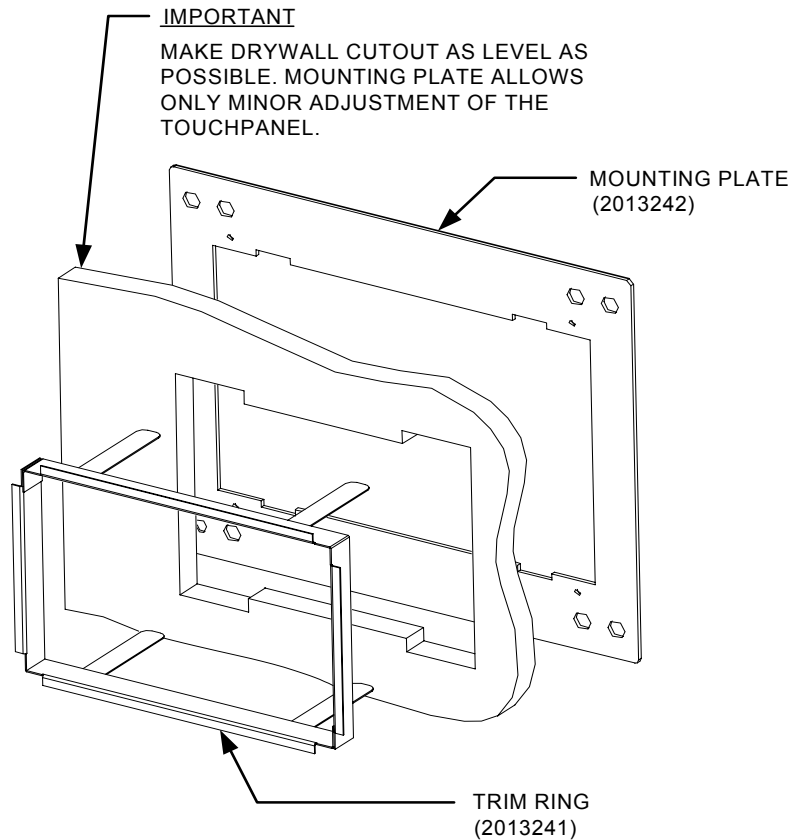

5. Carefully pass the mounting plate through the opening and hold it against the interior surface of the drywall.
6. When the mounting plate is in position, bend the top two flanges of the trim ring upward (approximately 90 degrees) and the bottom two flanges downward (approximately 90 degrees). Refer to the illustration on the following page.

---

**NOTE:** The mounting plate will have a slight play; this is normal. It allows for minor adjustments to the touchpanel during installation.

---

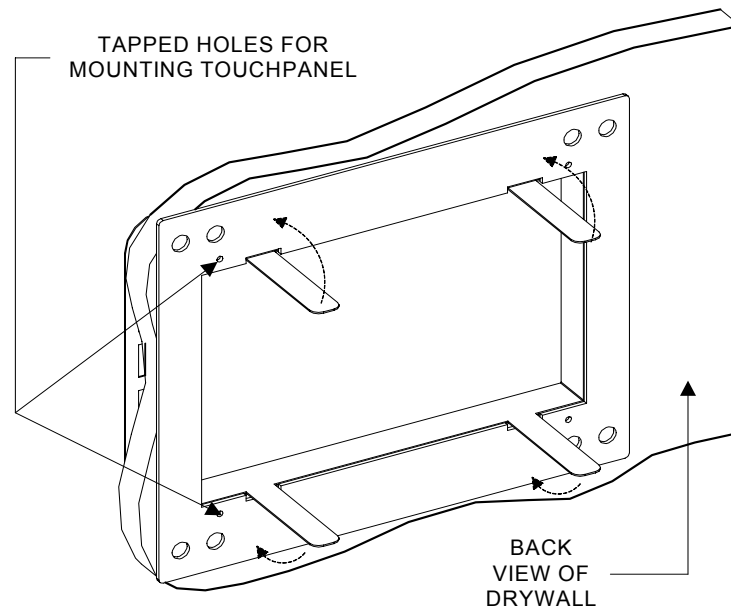
*Bend Flanges*

7. Run the necessary cables for the touchpanel and secure them behind the drywall.
8. The touchpanel can be installed using the four tapped holes in the mounting plate as indicated in the illustration above. Refer to the latest revision of the TPS-4L Operations and Installation Guide (Doc. 6449) for details. Refer also to the comprehensive illustration on the following page.

*Touchpanel Mounting Using WMKT-4L – Exploded View*

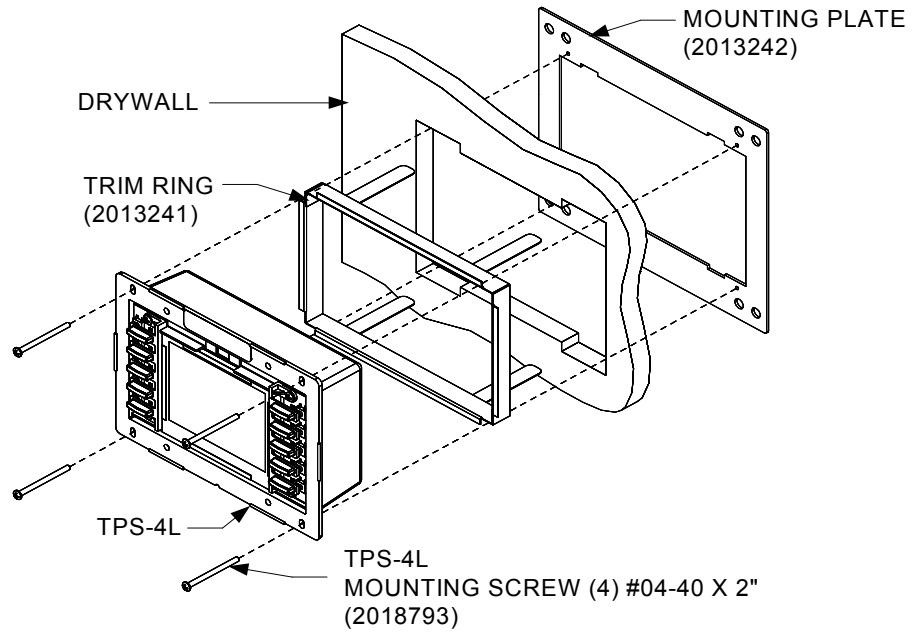

---

## Resources

### Industry Compliance

As of the date of manufacture, the TMK-4L and WMKT-4L have been tested and found to comply with specifications for CE marking.



### Reference Documents

The latest version of all documents mentioned within the guide can be obtained from the Crestron website ([www.crestron.com/manuals](http://www.crestron.com/manuals)). This link will provide a list of product manuals arranged in alphabetical order by model number.

#### *List of Related Reference Documents*

DOCUMENT TITLE
BB-4L Back Box
MMK-4L and WMKM-4L Mud Mount Kits
PMK-4L Pre-Construction Mounting Kit
TPS-4L Isys® 3.6" Wall Mount Touchpanel

### Further Inquiries

If you cannot locate specific information or have questions after reviewing this guide, please take advantage of Crestron's award winning customer service team by calling the Crestron corporate headquarters at 1-888-CRESTRON [1-888-273-7876]. For assistance in your local time zone, refer to the Crestron website ([www.crestron.com/offices](http://www.crestron.com/offices)) for a listing of Crestron worldwide offices.

You can also log onto the online help section of the Crestron website ([www.crestron.com/onlinehelp](http://www.crestron.com/onlinehelp)) to ask questions about Crestron products. First-time users will need to establish a user account to fully benefit from all available features.

### Future Updates

As Crestron adds improvements to the TMK-4L and WMKT-4L, additional information may be made available as manual updates. These updates are solely electronic and serve as intermediary supplements prior to the release of a complete technical documentation revision.

Check the Crestron website periodically for manual update availability and its relevance. Updates are identified as an “Addendum” in the Download column.

---

## Return and Warranty Policies

### Merchandise Returns / Repair Service

1. No merchandise may be returned for credit, exchange or service without prior authorization from CRESTRON. To obtain warranty service for CRESTRON products, contact an authorized CRESTRON dealer. Only authorized CRESTRON dealers may contact the factory and request an RMA (Return Merchandise Authorization) number. Enclose a note specifying the nature of the problem, name and phone number of contact person, RMA number and return address.
2. Products may be returned for credit, exchange or service with a CRESTRON Return Merchandise Authorization (RMA) number. Authorized returns must be shipped freight prepaid to CRESTRON, 6 Volvo Drive, Rockleigh, N.J. or its authorized subsidiaries, with RMA number clearly marked on the outside of all cartons. Shipments arriving freight collect or without an RMA number shall be subject to refusal. CRESTRON reserves the right in its sole and absolute discretion to charge a 15% restocking fee plus shipping costs on any products returned with an RMA.
3. Return freight charges following repair of items under warranty shall be paid by CRESTRON, shipping by standard ground carrier. In the event repairs are found to be non-warranty, return freight costs shall be paid by the purchaser.

### CRESTRON Limited Warranty

CRESTRON ELECTRONICS, Inc. warrants its products to be free from manufacturing defects in materials and workmanship under normal use for a period of three (3) years from the date of purchase from CRESTRON, with the following exceptions: disk drives and any other moving or rotating mechanical parts, pan/tilt heads and power supplies are covered for a period of one (1) year; touchscreen display and overlay components are covered for 90 days; batteries and incandescent lamps are not covered.

This warranty extends to products purchased directly from CRESTRON or an authorized CRESTRON dealer. Purchasers should inquire of the dealer regarding the nature and extent of the dealer's warranty, if any.

CRESTRON shall not be liable to honor the terms of this warranty if the product has been used in any application other than that for which it was intended or if it has been subjected to misuse, accidental damage, modification or improper installation procedures. Furthermore, this warranty does not cover any product that has had the serial number altered, defaced or removed.

This warranty shall be the sole and exclusive remedy to the original purchaser. In no event shall CRESTRON be liable for incidental or consequential damages of any kind (property or economic damages inclusive) arising from the sale or use of this equipment. CRESTRON is not liable for any claim made by a third party or made by the purchaser for a third party.

CRESTRON shall, at its option, repair or replace any product found defective, without charge for parts or labor. Repaired or replaced equipment and parts supplied under this warranty shall be covered only by the unexpired portion of the warranty.

Except as expressly set forth in this warranty, CRESTRON makes no other warranties, expressed or implied, nor authorizes any other party to offer any warranty, including any implied warranties of merchantability or fitness for a particular purpose. Any implied warranties that may be imposed by law are limited to the terms of this limited warranty. This warranty statement supersedes all previous warranties.

#### Trademark Information

*All brand names, product names and trademarks are the sole property of their respective owners. Windows is a registered trademark of Microsoft Corporation. Windows95/98/Me/XP/Vista and WindowsNT/2000 are trademarks of Microsoft Corporation.*



**Crestron Electronics, Inc.**  
15 Volvo Drive Rockleigh, NJ 07647  
Tel: 888.CRESTRON  
Fax: 201.767.7576  
[www.crestron.com](http://www.crestron.com)

**Installation Guide – DOC. 6390A**  
**(2013262)**

**11.07**

Specifications subject to  
change without notice.