

Shade Motor Bracket Installation and Motor Programming

The Crestron® CSA-DECOR3-BRKT Series shade brackets allow Crestron shades to be mounted on a wall, ceiling, pocket, or window jamb. The mounting brackets are adjustable to fine-tune the installation without removing the mounting brackets from the wall.



Shade Mounting

The CSA-DECOR3-BRKT Series shade brackets are mounted to the wall or window jamb using the two supplied brackets. The end caps (optional) and roller shade assembly then attach to the brackets.

CAUTIONS:

- There is risk of personal injury and equipment damage if the shade or associated parts fall during mounting. Use care when mounting. Use proper mounting hardware for the mounting surface (for example, screws or bolts) when securing the brackets to the surface.
- Two or more people are required to properly mount the shades. Three or more people are required to properly mount large shades and medium-sized coupled shades.

NOTES:

- The screws provided with the mounting brackets are intended for use on walls (or jambs) with wood or metal blocking. These screws should not be used for hollow drywall or masonry installations. It is the responsibility of the installer to make sure that the mounting method used is secure.
- Ensure that all mounting brackets are level and on the same plane.
- All shades must be aligned along a single axis (no off-angle positioning).

Mount the Brackets

1. Check for a proper fit by holding the roller shade assembly in the approximate mounting location. If using a fascia, use the fascia to measure the proper distance between mounting brackets. The brackets should be mounted flush with the end of the fascia.
2. Mark the locations of the brackets and make sure that the mounting points are level and on the same plane. Use a laser level or snap a chalk line to mark the locations of the brackets. The brackets should be spaced according to the specifications on the order form.

NOTE: End caps are used only when the shade is outside mounted and fascia is used. If inside mounted, end caps are not required unless the shade brackets protrude from the window opening. Adding end caps for an inside mount increases the light gap.

3. If using end caps, attach them to the mounting brackets according to their stamped directions. The end caps snap into place.

Shade Motor Bracket Installation and Motor Programming

4. Mount the brackets to the outside of the window frame (outside mount) or the inside of the window frame (inside mount). Use hardware that is appropriate for the mounting surface. Make sure the brackets are level and mounted to a flat surface.
 - The idler bracket mounts on the right-side of the window opening.
 - The motor bracket mounts on the left-side of the window opening.

NOTES:

- The stamped **L** and **R** should face the wall and window.
- For inside mounts, secure the mounting brackets into the window jamb or the window header.
- When using a fascia, align the brackets with the width of the fascia before attaching them to the header.

Inside Mount

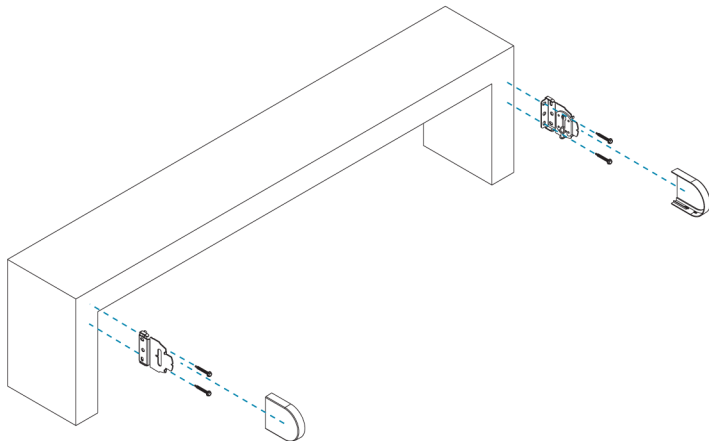

Outside Mount

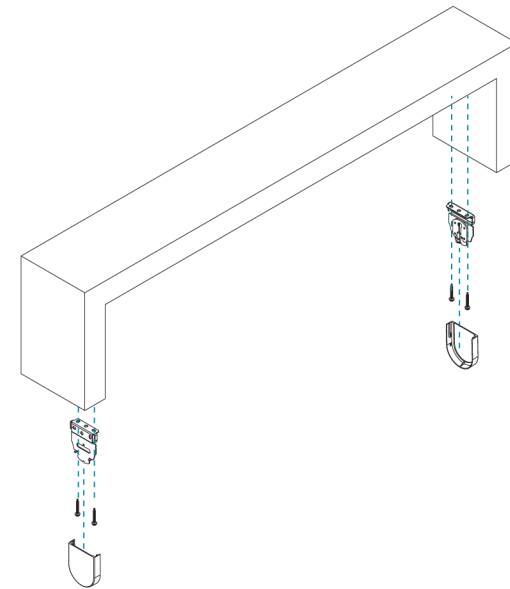

Shade Motor Bracket Installation and Motor Programming

Mount the Roller Shade Assembly

CAUTIONS:

- There is risk of personal injury and equipment damage if the shade or associated parts fall during installation. Use care when mounting. Use proper mounting hardware (e.g., screws or bolts) for the mounting surface when securing the brackets to the surface.
- Proper installation of shades requires two or more people. Large shades and medium-sized coupled shades will require three people.

Once the mounting brackets are installed, mount the roller shade assembly:

1. Insert the idler pin into the top of the keyhole on the right bracket, and slide it down into the keyhole. The idler pin sits on the vertical adjustment screw.

Insert the Idler Pin into the Keyhole

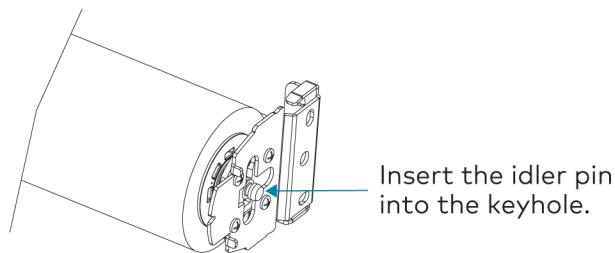

2. Raise the motor end of the roller shade assembly to the motor bracket.
3. Push the roller shade assembly toward the idler bracket to compress the spring on the idler pin.

4. Push the tab on the motor assembly into the hole in the motor bracket. When the shade is properly seated, the two clips spring down to secure the motor to the bracket. Make sure that the shade is properly mounted before letting go.

Secure the Motor to the Motor Bracket

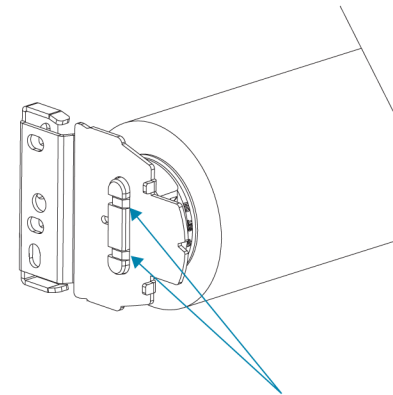

Maneuver the motor end into the bracket slot.

Plastic clips lock the motor into the motor bracket when it is fully inserted into the motor bracket.

Pull the motor gently to ensure that the motor is securely locked in place.

Shade Motor Bracket Installation and Motor Programming

Adjust the Roller Shade Assembly

Once the roller shade assembly is mounted, make adjustments to level the shade and center it in the opening.

WARNINGS:

- Care has been taken to make sure that the shade is properly balanced. Prior to initial operation, please confirm that the brackets have been adjusted so that the shade hangs level and plumb. Upon startup, run the shade all the way down and check for plumb. Observe the shade closely as it rolls up. If the shade begins to telescope, stop immediately and take the appropriate action to make sure that the shade tracks properly. To prevent damage to the fabric from telescoping, do not leave the shade unattended during the first few cycles of operation. Failure to follow these instructions may result in damage to the edge of the fabric, which is not covered by the warranty.
- If the roll-up diameter is close to the maximum allowance, do not use the vertical adjustment screw to level the shade. The fabric may come in contact with the bracket, fascia, or other hardware, which may cause damage to the fabric. Remount the bracket to level the shade.

Situations that may cause telescoping:

- The shade is not perfectly level.
- The shade may bump into objects while traveling up or down.
- The HVAC ductwork is blowing on the shade, or air is coming in through a window.
- A foreign object is stuck to the shade fabric (for example tape, bugs, dust, etc.).

Ways to prevent telescoping:

- Use the leveling features built into the shade brackets to make sure the shade is level. If the bracket adjustment is not enough to compensate, use a shim to level the system.

- Make sure that no obstructions exist near the window area that the shade could bump into while traveling (for example, latches and cranks).
- Direct HVAC airflow away from the shade, and make sure that windows are closed while operating the shade.
- Lower the shade all the way down to the bare tube (the shade will need to be placed into **Limit Setup** mode to allow the shade to travel below its lower limit). Inspect the front and back of the shade to make sure that no foreign objects are stuck to the shade fabric.

Adjust the Roller Shade Assembly

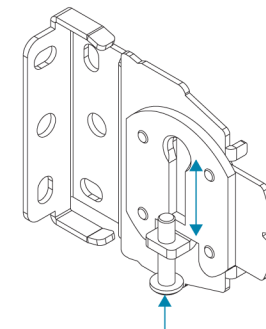

Tighten or loosen the screw to level the shade.

If the shade is still telescoping, it can be re-shimmed by applying a small (1 in. x 1 in.) piece of tape to the end of the tube that the fabric should move toward. Make sure that the tape is placed on the bare tube for best results. The shade must be rolled all the way down past its lower limit. To do this, place the shade motor into **Limit Setup** mode.

- If the fabric is telescoping to the left, place the tape on the right side of the tube.
- If the fabric is telescoping to the right, place the tape on the left side of the tube.

Shade Motor Bracket Installation and Motor Programming

Swap the Idler and Motor Ends

The roller shade assembly can be mounted so that the idler and motor ends are located in the ends of the tube opposite where they were when received from the factory (i.e., the idler end is on the left and the motor end is on the right). When the idler bracket is mounted, the keyhole in the idler bracket must be parallel with the wall; the head of the adjustment screw must face down. The keyhole can be rotated so that it is in the correct orientation. Refer to the illustrations below for keyhole orientation based on mounting location.

Swapping the hardware requires a Phillips screwdriver.

Left-Side Idler Bracket Wall Mount

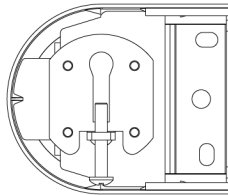

Right-Side Idler Bracket Wall Mount

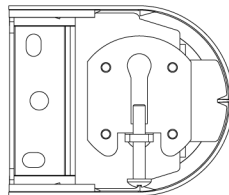

Left- or Right-Side Idler Bracket Ceiling or Header Mount

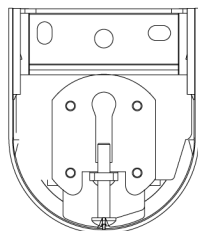

Rotate the keyhole

1. Using a Phillips screwdriver, remove the four screws holding the idler mount in the left-hand bracket and then remove the idler mount. Keep all hardware for reassembly.
2. Reassemble the idler mount and the left-hand bracket so that the keyhole is parallel to the wall when the bracket is mounted. Make sure that the screw head on the vertical adjustment screw faces down.
3. Secure the idler mount with the screws removed in step 1.

Shade Motor Bracket Installation and Motor Programming

Rotate Keyhole: Right-Side Wall Mount to Ceiling Mount

Remove the screws and separate the keyhole from the idler bracket.

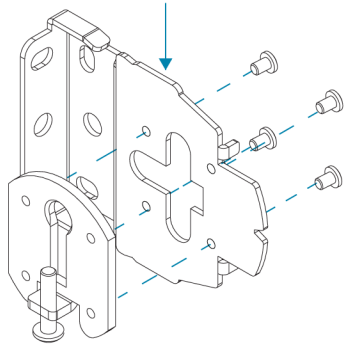

Reassemble the bracket. Ensure the keyhole is parallel with the wall when it is mounted.

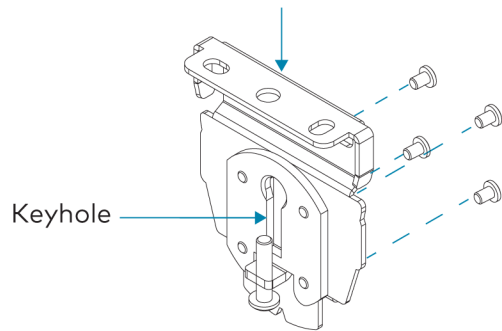

Rotate Keyhole: Right-Side Wall Mount to Left Side Wall Mount

Remove the screws and separate the keyhole from the idler bracket.

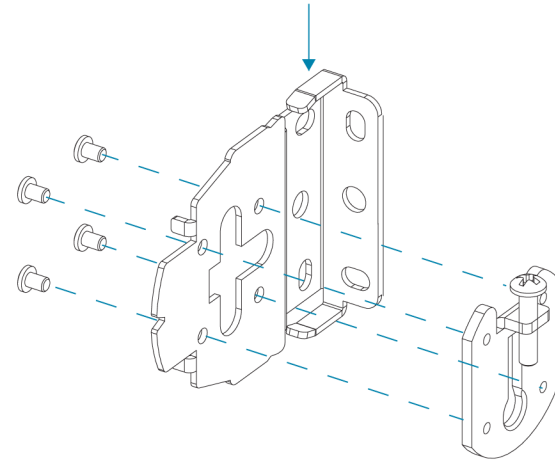

Reassemble the bracket. Ensure the keyhole is parallel with the wall when it is mounted.

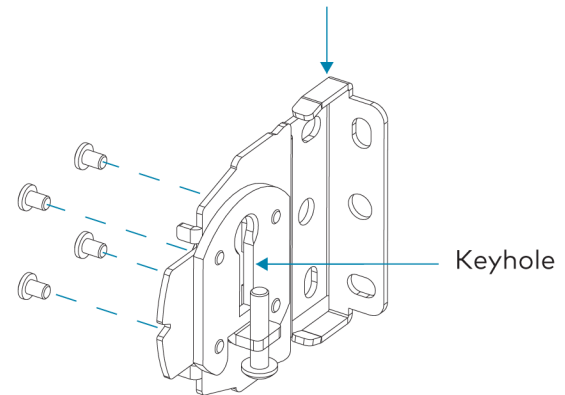

Shade Motor Bracket Installation and Motor Programming

Swap the Roller Shade Idler and Motor

If the idler and motor brackets have been swapped, remove the motor and idler from the tube and remount in the opposite ends, allowing the fabric to roll off of the tube in its intended manner

Swap the idler and motor ends of the roller shade.

1. Remove the motor by pulling on the motor head.
2. Use the idler removal tool to loosen the idler by rotating the idler counterclockwise. Pull the idler out of the tube.
3. Insert the motor into the tube end opposite from where it was removed.
4. Insert the idler into the tube end opposite from where it was removed.
5. Use the idler removal tool to tighten the idler; rotate the idler clockwise two turns, and then tighten until snug. Pull on the idler to confirm it is properly secured.



Motor Wiring

Routing the Cables

To ensure proper functionality and a clean look, consider the following when routing cables and making connections:

- The cables should exit the wall near the motor end of the shade assembly.
- Route the cables so that they remain out of sight.
- The brackets provide a cutout in the upper corner, which allows wiring to be easily run to the motor.
- A 2-pin connector may be required for shades with a large roll-up diameter.
- Use cable ties to secure the cables to the loop on the bracket.
- Ensure that the cables and connectors do not make contact with the shade fabric.

Making the Connections

NOTES:

- When making the connections, do not use CRESNET-HP cable with the small connector. When using CRESNET-HP cable, replace the connector on the motor pigtail with the larger connector that is supplied with the shade.
- All shades should be home run from the power supply (sold separately).

Shade Motor Bracket Installation and Motor Programming

Cresnet QMT® Shade Motor with the Power and Control Coming from the Same Source

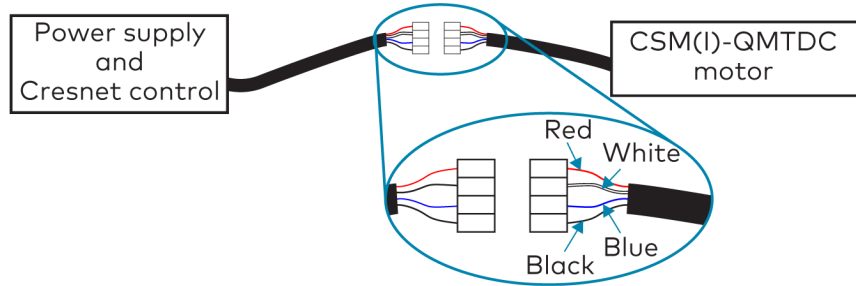

Cresnet QMT Shade Motor with the Power and Control Coming from Separate Sources

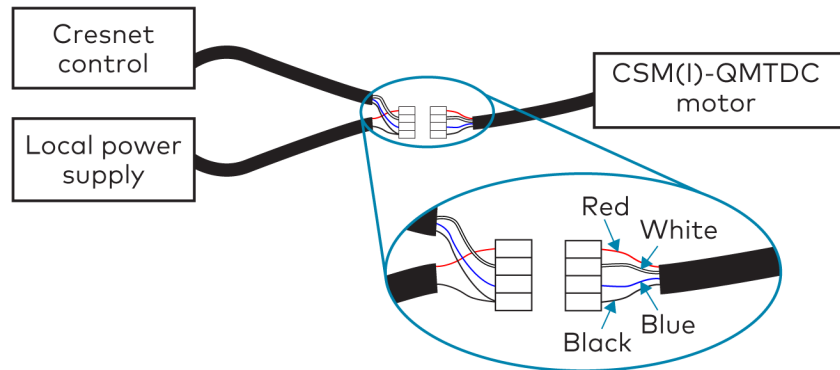

Wire the inNET EX® Wireless QMT Shade Motor

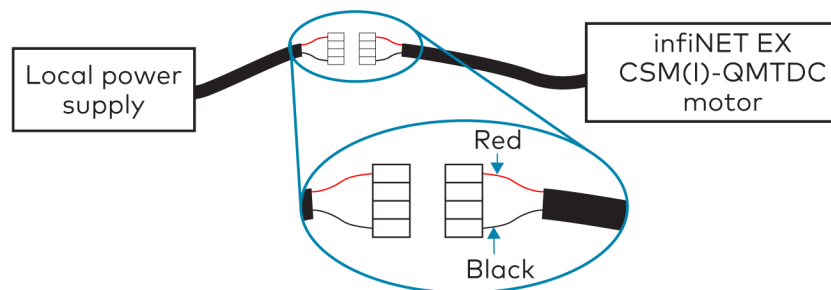

Motor Programming

The Crestron® digital CSM(I)-QMTDC shade motors are programmed locally using the buttons on the motor. The information in this guide serves as a detailed programming overview of the Crestron CSM(I)-QMTDC shade motors.

NOTE: The procedures described in this document can also be performed remotely using a control system. The timeout and LED indicators are the same as described in this document.

Controls and Indicators

The Crestron CSM(I)-QMTDC shade motors have **UP**, **SET**, and **DN** (down) push buttons that are used to program the shade. The shade motors have a multicolor LED that lights red, amber, green, blue, or white to provide confirmation, operating mode, and error state feedback. The **UP** button is located closest to the LED, the **SET** button is the second button from the LED, and the **DN** button is the third button from the LED.

Crestron CSM-QMTDC Motor Multicolor LED and Push Button Orientation

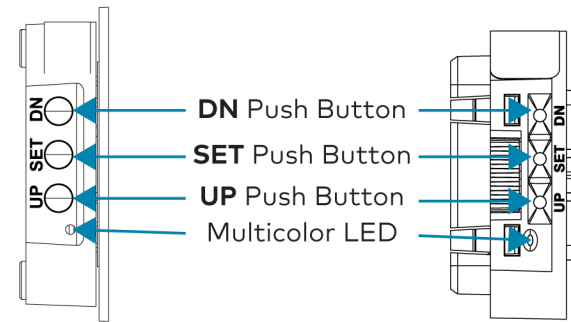

Shade Motor Bracket Installation and Motor Programming

Test the Shade

Before the shade is operated, test the motor to ensure that the shade travels in the correct direction when being operated.

NOTE: Before using the CSM(I)-QMTDC shade motor, ensure the device is using the latest firmware. Check for the latest firmware for the CSM (I)-QMTDC shade motor at www.crestron.com/firmware. Firmware is loaded onto the device using Crestron Toolbox™ software.

Test the Motor Direction

Press the **DN** button to lower the shade about 1 inch. If the shade travels up, reverse the motor direction.

NOTE: Reversing the motor direction resets all previously set limits. After either the upper or lower limit is set, the motor automatically enters **Limit Setup** mode for the opposite limit. Follow the procedure in [Set the Shade Limits](#) to reassign limits.

To reverse the shade direction, press and hold the **SET** button for 10 seconds. The red LED lights for 3 seconds.

Test the Shade Travel

Test the travel of the shade fabric to ensure that it does not come in contact with building materials and that the upper and lower shade limits are properly set.

WARNING: Care has been taken to ensure that the shade is properly balanced. Prior to initial operation, confirm that the brackets are adjusted so that the shade hangs level and plumb. Upon startup, run the shade all the way down and check for plumb. Observe the shade closely as it rolls up. If the shade begins to telescope, stop immediately and take the appropriate action to ensure the shade tracks properly. To prevent damage to the fabric from telescoping, do not leave the shade unattended during the first few cycles of operation. Failure to follow these instructions may result in damage to the edge of the fabric, which is not covered by the warranty.

NOTE: For Crestron Horizontal Sheers, the lower limit is defined as the point before the hem bar tilts.

To test the lower limit:

1. Using the **DN** button, lower the shade until it reaches its lower limit. Stop and adjust the mounting brackets if the fabric contacts any building materials.
2. Verify that the shade stops at the desired lower limit. If the shade does not travel to the desired lower limit, adjust the shade limits. For details, refer to [Set the Shade Limits](#).

To test the upper limit:

1. Using the **UP** button, raise the shade until it reaches its upper limit. Stop and adjust the mounting brackets if the fabric contacts any building materials.
2. Verify that the shade stops at the desired upper limit. If the shade does not travel to the desired upper limit, adjust the shade limits. For details, refer to [Set the Shade Limits](#).

Shade Motor Bracket Installation and Motor Programming

Set the Shade Limits

If necessary, set the lower and upper shade limits. If the shade limits are not set, the red LED flashes three times, pauses for 1 second, flashes once, pauses for 5 seconds, and then repeats this code until the limits are set.

NOTES:

- **Limit Setup** mode exits after 8 seconds of inactivity.
- If a limit is not set after the upper or lower limit is saved, the motor automatically enters **Limit Setup** mode for the opposite limit. This typically occurs after the motor direction has been reversed and both limits are erased.
- For Crestron Horizontal Sheers, the lower limit is defined as the point before the hem bar tilts.

Set the lower limit for the shade:

1. Press and hold the **SET** button for 4 seconds to enter **Limit Setup** mode. The LED alternates between amber and green.
2. Press and release the **DN** button to begin lower limit setup. The green LED flashes.
3. Use the **UP** and **DN** buttons to set the shade to its desired position.
4. Press and hold **SET** for 4 seconds. The LED turns solid red to confirm that the lower limit was successfully set.

Set the upper limit for the shade:

1. Press and hold **SET** for 4 seconds to enter **Limit Setup** mode. The LED alternates between amber and green.
2. Press and release the **UP** button to begin upper limit setup. The amber LED flashes.
3. Use the **UP** and **DN** buttons to set the shade to its desired position.
4. Press and hold **SET** for 4 seconds. The LED turns solid red to confirm that the upper limit was successfully set.

Joining an infiNET EX® Network (infiNET EX Interfaces Only)

The device connects to the Crestron network via the infiNET EX communications protocol. Use the procedures outlined below to join or leave an infiNET EX network and to verify communications between the device and the control system.

Joining an infiNET EX Network

Before a device can be used in a lighting system, it must first join an infiNET EX network by being acquired.

NOTE: A device can be acquired by only one gateway.

1. Put the infiNET EX gateway into **Acquire** mode from the unit itself or from Crestron Toolbox, as described in its manual at www.crestron.com/manuals.

NOTE: In an environment where multiple gateways are installed, only one gateway should be in **Acquire** mode at any time.

2. Place the device into **Acquire** mode.
 - a. Press the **SET** button three times, and then press and hold it down (tap-tap-tap-press+hold) until the white LED on the device flashes once (this can take up to 10 seconds).
 - b. Release the button to start the acquire process. The LED flashes slowly to show that the device is actively scanning the infiNET EX network.
 - The LED turns on for 5 seconds to show that the device has been successfully acquired to the infiNET EX network.
 - The LED flashes quickly to indicate that the device was not successfully acquired by the infiNET EX network. Press the **SET** button to acknowledge failure to acquire the infiNET EX network. Ensure the gateway is in **Acquire** mode and within range before attempting the acquire process again.

Shade Motor Bracket Installation and Motor Programming

- Once all devices have been acquired, take the gateway out of **Acquire** mode. Refer to the gateway's manual for details.

Leaving an infiNET EX Network

To leave an infiNET EX network, put the device into **Acquire** mode, as described in [Joining an infiNET EX Network](#) when no gateway is in **Acquire** mode.

Verifying Communications Status

To check the communications status of the device, tap the **SET** button three times and then press and hold it down (tap-tap-tap-press+hold) for up to 2 seconds. The LED flashes to indicate the communications status. Refer to the following table for details.

LED	Communications Status
Turns on for 5 seconds	The device is communicating with the control system.
Flashes twice	The device was previously joined to the network but is not communicating with the gateway.
Flashes once	The device is not joined to the network.

LED Diagnostics

The LED flashes to provide a visual reference that the motor is operating normally or if it is in an error state.

Normal Operation

The following table provides a list of possible LED patterns encountered during normal operation. All LEDs extinguish after 1 minute of inactivity if there are no errors to report.

LED Patterns

LED Pattern	LED Color	Operating Mode
Two fast flashes, then pause (1/8-second on, 1/8-second off, 1/8-second on, 5/8-second off)	Blue	A firmware upgrade over the Cresnet® network is in progress.
Slow flash (1/2-second on, 1/2-second off)	Blue	The motor's internal firmware upgrade is in progress.
Solid	Blue	The motor is in Bootloader mode.
Fast flash (1/4-second on, 1/4-second off)	White	The motor is in Identify mode.
Slow flash (1/2-second on, 1/2-second off)	Green	The motor is moving from a local button press.
Solid	Green	The motor is communicating with the control system program.
Slow flash (1/2-second on, 1/2-second off)	Red	The motor is not communicating with the control system.

Shade Motor Bracket Installation and Motor Programming

Error State

Crestron CSM(I)-QMTDC motors display error codes using the red LED on the interface. The LED flashes a pattern to indicate the error.

For example, when a 3-3 LED flash pattern occurs, the LED flashes three times, pauses for 1 second, flashes three times, pauses for 5 seconds, and then repeats until the error is corrected. When a 2-1 LED flash pattern occurs, the LED flashes two times, pauses for 1 second, flashes once, pauses for 5 seconds, and then repeats this code until the error is corrected.

The flash patterns are listed in the following table. Refer to [Troubleshooting](#) for possible corrections.

LED Blinking Patterns

LED Error Code	Error State
3-1	The motor limits are not set.
3-3	An obstruction is blocking the shade fabric from moving freely.
3-4	A motor over-current error exists. Check for obstacles or any sources of excessive friction.
3-5	A motor duty-cycle error exists. Reduce the operating duty cycle of the motor to correct the error.
3-6	There is a communications error between the motor and Cresnet or infiNET EX control board.
2-1	There is no traffic on the network. Check to ensure that proper Cresnet wiring is maintained, or for infiNET EX devices, ensure that the motor is connected to a gateway.
2-2	The motor is not being polled by the control system. Ensure that the Net ID matches the control system program and that the program is running on the control system.

Troubleshooting

The following table provides corrective action for possible trouble situations. If further assistance is required, please contact a Crestron customer service representative.

Crestron CSM(I)-QMTDC Motor Troubleshooting

Trouble	Possible Cause(s)	Action
The motor cannot be controlled, and all of the LEDs are off.	There is no power provided to the motor.	Check the power connections between the power supply and motor.
	The power connection is reversed between the motor and the power supply.	Ensure that the power connection to the motor is not reversed.
The motor moves in the opposite direction.	The motor direction is reversed.	Reverse the direction of the motor.
The motor intermittently stops working.	The motor is exceeding its maximum duty cycle.	Reduce the duty cycle of the motor operation.
	The motor is encountering an obstacle or excessive friction, which is causing it to stop.	Verify that all components are aligned and running smoothly.
	The load on the motor is exceeding its maximum rating.	Verify that the fabric weight and tube size do not exceed the rating for the motor.
The LED is blue.	The motor is stuck in the bootloader.	Reload firmware to the motor.

Shade Motor Bracket Installation and Motor Programming

Additional Information

Original Instructions

The U.S. English version of this document is the original instructions. All other languages are a translation of the original instructions.

Crestron product development software is licensed to Crestron dealers and Crestron Service Providers (CSPs) under a limited nonexclusive, nontransferable Software Development Tools License Agreement. Crestron product operating system software is licensed to Crestron dealers, CSPs, and end-users under a separate End-User License Agreement. Both of these Agreements can be found on the Crestron website at www.crestron.com/legal/software_license_agreement.

The product warranty can be found at www.crestron.com/warranty.

The specific patents that cover Crestron products are listed at www.crestron.com/legal/patents.

Certain Crestron products contain open source software. For specific information, visit www.crestron.com/opensource.

©2020 Crestron Electronics, Inc.

Doc. 7733D

07/17/20