

# Crestron **MMK-3100L & WMKM-3100L** Mud Mount Kits

---

## Installation Guide



This document was prepared and written by the Technical Documentation department at:



Crestron Electronics, Inc.  
15 Volvo Drive  
Rockleigh, NJ 07647  
1-888-CRESTRON

# Mud Mount Kits: MMK-3100L & WMKM-3100L

---

## Description

Mud Mount Kits are the preferred mounting option for the Crestron Isys<sup>®</sup> TPS-3100L series of lectern/wall-mounted video touchpanel when cutouts made in the drywall for touchpanel installation are too large. These kits provide support for additional plastering that can be applied to hide large irregularities in the touchpanel cutout.

There are two Mud Mount Kits. The MMK-3100L is a pre-construction accessory. Pre-construction refers to framed walls prior to hanging drywall. This accessory must be used with either the Pre-Construction Mount Kit (PMK-3100L) or Back Box Kit (BB-3100L).

The WMKM-3100L is a post-construction kit. Post-construction refers to framed walls with drywall hung. This accessory is designed with a mounting plate so that it can be placed anywhere on a wall without the support from a stud.

---

**NOTE:** If necessary, consult the latest revision of the TPS-3100L Operations Guide (Doc. 6291) for a complete list of mounting options.

---



---

## Supplied Hardware

The MMK-3100L consists of three parts. These parts produce an assembly that attaches to the PMK-3100L or BB-3100L. The WMKM-3100L consists of the same three parts that make up the MMK-3100L as well as one mounting plate. The mounting plate is the part that provides the necessary support for post-construction applications.

### *Supplied Hardware of the MMK-3100L and WMKM-3100L*

DESCRIPTION	PART NUMBER	QUANTITY
Metal Plate, Mounting (WMKM-3100L only)	2010620	1
Metal Plate, Mud Ring	2010621	1
Metal Plate, Fastener	2004825	2
Hardware, Push-On Fastener	2004121	4

The dimensions of the MMK-3100L/WMKM-3100L are shown below.

**Dimensional Drawing**

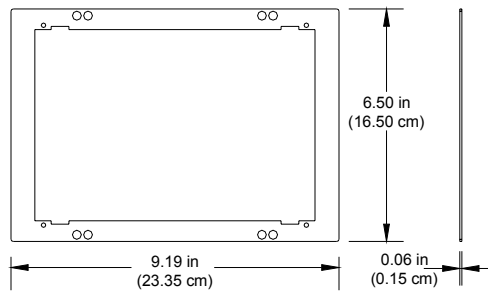

**MOUNTING PLATE FOR  
WMKM-3100L**

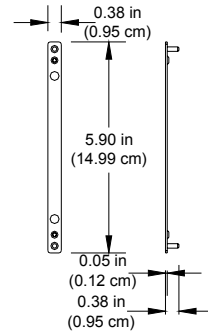

**FASTENER PLATE FOR  
WMKM-3100L AND MMK-3100L**

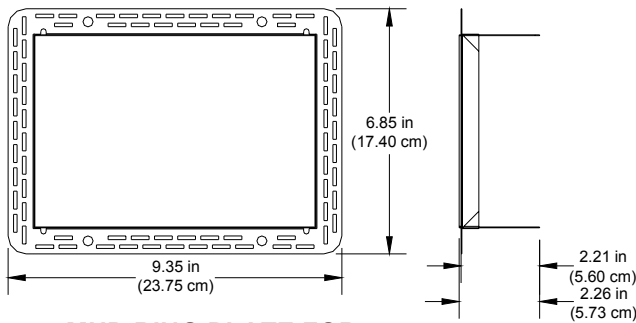

**MUD RING PLATE FOR  
WMKM-3100L AND MMK-3100L**

**Drywall Cutout Dimensions**

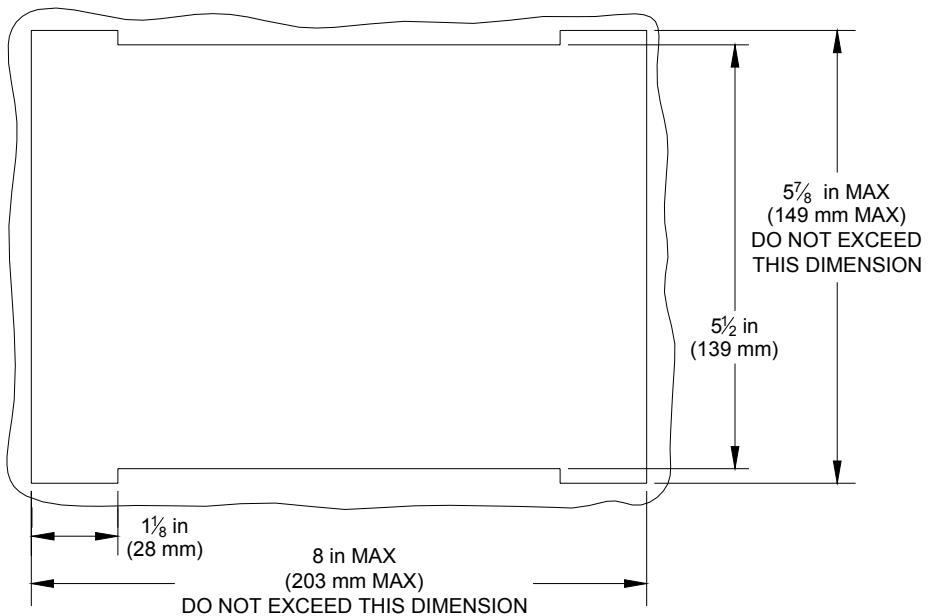

## Installation

This section provides an installation procedure for each Mud Mount Kit. The procedure for the MMK-3100L starts below and the “WMKM-3100L Procedure” starts on page 5.

### MMK-3100L Procedure

The procedure in this section provides the necessary steps for the assembly of the MMK-3100L to either the PMK-3100L or BB-3100L. It is assumed that the PMK-3100L or BB-3100L has been secured to the stud according to the procedures in the latest revisions of their respective Installation Guides (Doc. 6297 and Doc. 6298, respectively). Also, it is assumed that drywall is in place and a rectangular cutout for the touchpanel is made in the drywall (refer to the Drywall Cutout dimensions on the previous page for cutout dimensions).

Complete the steps in the order provided. The only tools or materials required and not supplied are a drywall saw or equivalent, four standard drywall screws, #2 Phillips screwdriver, a level, and tools/material to apply drywall joint compound.

---

**NOTE:** The illustrations in this procedure show the installation of the MMK-3100L with the PMK-3100L. Even though the illustrations only show the PMK-3100L, they are identical for the BB-3100L as well.

---

1. Pass a fastener plate through the opening and align its two center holes with the top two pins on the PMK-3100L. Verify that the pins on the fastener plate are not between the fastener plate and the PMK-3100L. Refer to the illustration after this step for visual guidance.

#### *Secure Fastener Plates to PMK-3100L (or BB-3100L)*

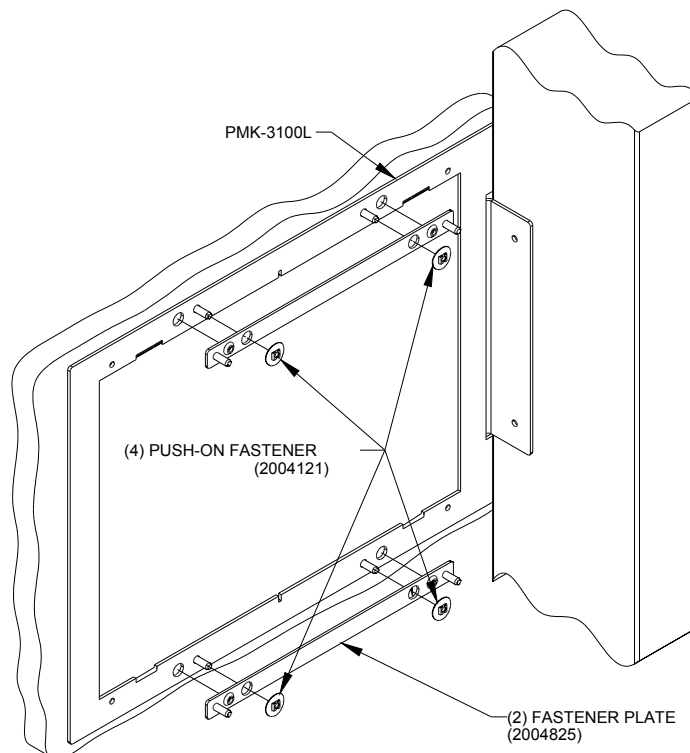

2. Slide a push-on fastener over each pin of the PMK-3100L (or BB-3100L) to loosely secure the fastener plate and the mounting plate. Do not push the push-on fasteners all the way down onto the pins. Slide them on enough to keep the fastener plate and mounting plate as one fastener/mounting plate assembly.
3. Use the second fastener plate and repeat steps 1 and 2 using the lower two PMK-3100L (or BB-3100L) pins.

---

**NOTE:** When installing into the PMK-3100L, verify that the 18 AWG bus wire securing the cables for the touchpanel remain attached.

---

4. Verify that the drywall cutout meets the measurements specified on page 2.
5. Insert the symmetrical mud ring plate into the opening, as shown in the illustration after this step.

***Insert and Secure Mud Ring Plate into PMK-3100L (or BB-3100L)***

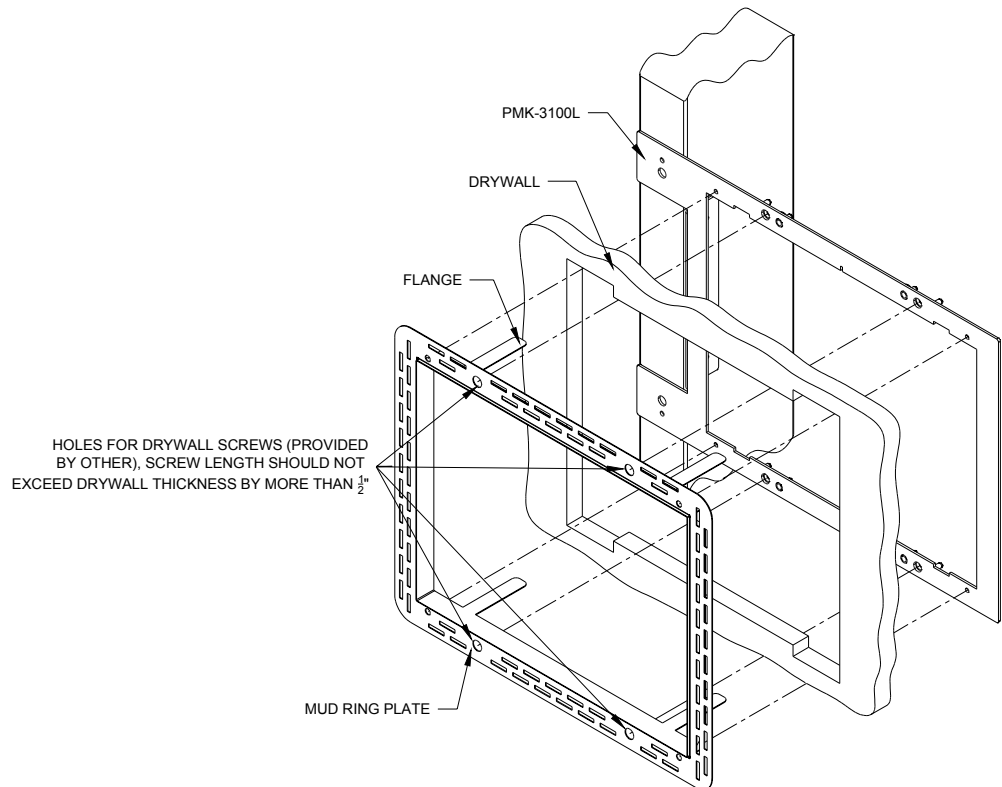

6. When the mud ring plate is in position, bend the top two flanges of the plate upward and the bottom two flanges downward.
  - If mounting into the PMK-3100L, bend the flanges approximately 90 degrees.
  - If mounting into the BB-3100L, bend the flanges back as far as they can go.

7. Use four standard drywall screws (length should not exceed drywall thickness by more than ½ inch) to secure the mud ring plate to the rest of the assembly. The screws pass through the clearance holes in the PMK-3100L (or BB-3100L) and are secured in the extruded holes of the fastener plates.
8. Verify that the mud ring plate is level.

---

**NOTE:** Do not over tighten screws. Doing so may over-dimple or rip the mud ring plate.

---

9. Use a #2 Phillips screwdriver and tighten the drywall screws by hand so that they slightly dimple into the holes in the mud ring plate.
10. Apply drywall joint compound as needed to finish the cutout. Avoid covering the four tapped mounting holes.
11. Run the necessary cables for the touchpanel and secure them behind the drywall.
12. When dry, the TPS-3100L can be installed using the four tapped holes in the PMK-3100L. Refer to the latest revision of the TPS-3100L Operations Guide (Doc. 6291) for details.

## WMKM-3100L Procedure

The procedure in this section provides the necessary steps for the assembly and installation of the WMKM-3100L into a wall. Complete the steps in the order provided. The only tools or materials required and not supplied are a drywall saw or equivalent, a level, four standard drywall screws, #2 Phillips screwdriver, and tools/material to apply drywall joint compound.

1. Insert the two pins on one fastener plate into the top two outer holes on the mounting plate, as shown in the following illustration.

### *Create the Fastener/Mounting Plate Assembly*

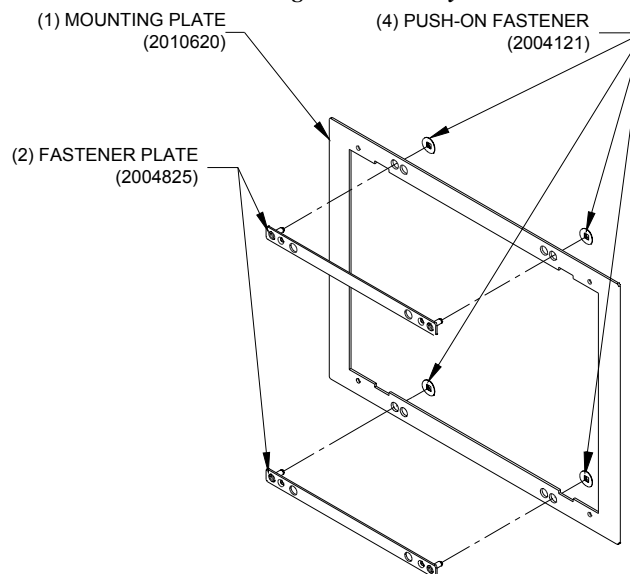

2. Slide a push-on fastener over each pin on the fastener plate to loosely secure the fastener plate and the mounting plate. Do not push the push-on fasteners all the way down onto the pins. Slide them on enough to keep the fastener plate and mounting plate as one fastener/mounting plate assembly.
3. Use the second fastener plate and repeat steps 1 and 2 using the lower two PMK-3100L pins.
4. Locate an area on the wall that is free of miscellaneous wiring and studs.
5. Make a small hole near the middle of the designated site; verify that the location is suitable.

---

**NOTE:** Make the cutout as level as possible. The mounting plate allows for only minor leveling adjustments.

---

6. Use the drywall saw or equivalent to produce a level, rectangular cutout in the drywall as shown on page 2.
7. Insert the symmetrical mud ring plate into the opening, as shown in the illustration after this step.

***Insert the Mud Ring Plate into the Opening***

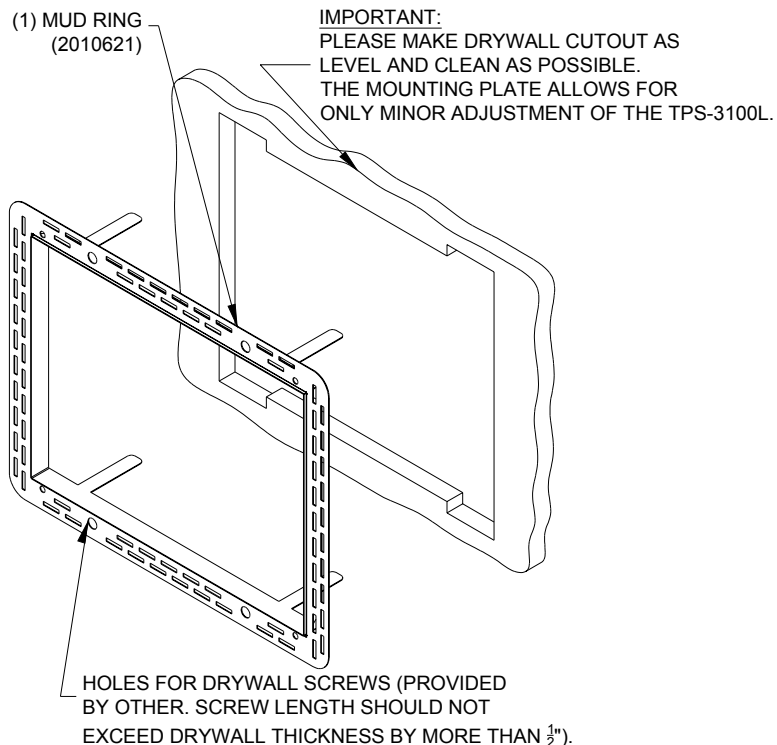

8. Carefully pass the fastener/mounting plate assembly through the opening and rest the assembly against the interior surface of the drywall. Verify that the fastener plates are between the mounting plate and the drywall.



9. When the fastener/mounting plate assembly is in position, bend the top two flanges of the mud ring upward (approximately 90 degrees) and the bottom two flanges downward (approximately 90 degrees). Refer to the illustration after this step.

---

**NOTE:** Fastener/mounting plate assembly will have slight play; this is normal. It allows for minor adjustments to the TPS-3100L during installation.

---

***Bend Flanges***

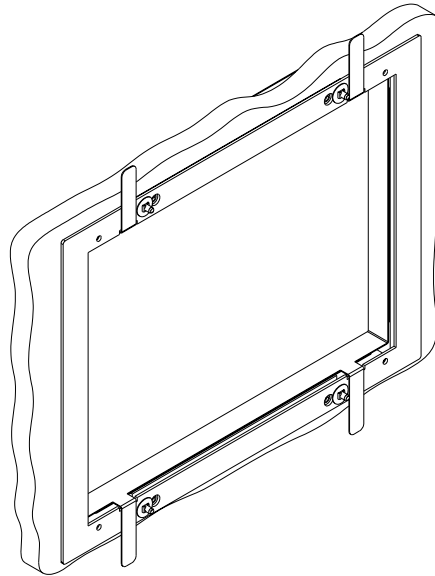

10. Use four standard drywall screws (of adequate length) to secure the plate to the fastener/mounting plate assembly. The screws pass through the clearance holes in the plate and are secured in the extruded holes of the fastener plates.
11. Verify that the plate is level before tightening.

---

**NOTE:** Do not over tighten screws. Doing so may over-dimple or rip the plate.

---

12. Use a #2 Phillips screwdriver and tighten the drywall screws by hand so that they slightly dimple into the holes in the mud ring plate.
13. Run the necessary cables for the touchpanel and secure them behind the drywall.
14. Apply drywall joint compound as needed to finish the cutout. Avoid covering the four tapped mounting holes.
15. When dry, the TPS-3100L can be installed using the four tapped holes in the mounting plate. Refer to the latest revision of the TPS-3100L Operations Guide (Doc. 6291) for details.

---

## Further Inquiries

If after reviewing this Installation Guide, you cannot locate specific information or have questions, please take advantage of Crestron's award winning customer service team by calling:

- In the US and Canada, call Crestron's corporate headquarters at 1-888-CRESTRON [1-888-273-7876].
- In Europe, call Crestron International at +32-15-50-99-50.
- In Asia, call Crestron Asia at +852-2341-2016.
- In Latin America, call Crestron Latin America at +5255-5093-2160.
- In Australia and New Zealand, call Crestron Control Solutions at +61-2-9737-8203.

You can also log onto the online help section of the Crestron website ([www.crestron.com](http://www.crestron.com)) to ask questions about Crestron products. First-time users will need to establish a user account to fully benefit from all available features.

As of the date of manufacture, the MMK-3100L and WMKM-3100L have been tested and found to comply with specifications for CE marking.



---

## Future Updates

As Crestron adds improvements to the MMK-3100L or WMKM-3100L, additional information may be made available as manual updates. These updates are solely electronic and serve as intermediary supplements prior to the release of a complete technical documentation revision.

Check the Crestron website ([www.crestron.com](http://www.crestron.com)) periodically for manual update availability and its relevance. Updates are available from the Download | Product Manuals section and are identified as an “Addendum” in the Download column.

---

## Return and Warranty Policies

### Merchandise Returns / Repair Service

1. No merchandise may be returned for credit, exchange, or service without prior authorization from CRESTRON. To obtain warranty service for CRESTRON products, contact the factory and request an RMA (Return Merchandise Authorization) number. Enclose a note specifying the nature of the problem, name and phone number of contact person, RMA number, and return address.
2. Products may be returned for credit, exchange, or service with a CRESTRON Return Merchandise Authorization (RMA) number. Authorized returns must be shipped freight prepaid to CRESTRON, 6 Volvo Drive, Rockleigh, N.J., or its authorized subsidiaries, with RMA number clearly marked on the outside of all cartons. Shipments arriving freight collect or without an RMA number shall be subject to refusal. CRESTRON reserves the right in its sole and absolute discretion to charge a 15% restocking fee, plus shipping costs, on any products returned with an RMA.
3. Return freight charges following repair of items under warranty shall be paid by CRESTRON, shipping by standard ground carrier. In the event repairs are found to be non-warranty, return freight costs shall be paid by the purchaser.

### CRESTRON Limited Warranty

CRESTRON ELECTRONICS, Inc. warrants its products to be free from manufacturing defects in materials and workmanship under normal use for a period of three (3) years from the date of purchase from CRESTRON, with the following exceptions: disk drives and any other moving or rotating mechanical parts, pan/tilt heads and power supplies are covered for a period of one (1) year; touchscreen display and overlay components are covered for 90 days; batteries and incandescent lamps are not covered.

This warranty extends to products purchased directly from CRESTRON or an authorized CRESTRON dealer. Purchasers should inquire of the dealer regarding the nature and extent of the dealer's warranty, if any.

CRESTRON shall not be liable to honor the terms of this warranty if the product has been used in any application other than that for which it was intended, or if it has been subjected to misuse, accidental damage, modification, or improper installation procedures. Furthermore, this warranty does not cover any product that has had the serial number altered, defaced, or removed.

This warranty shall be the sole and exclusive remedy to the original purchaser. In no event shall CRESTRON be liable for incidental or consequential damages of any kind (property or economic damages inclusive) arising from the sale or use of this equipment. CRESTRON is not liable for any claim made by a third party or made by the purchaser for a third party.

CRESTRON shall, at its option, repair or replace any product found defective, without charge for parts or labor. Repaired or replaced equipment and parts supplied under this warranty shall be covered only by the unexpired portion of the warranty.

Except as expressly set forth in this warranty, CRESTRON makes no other warranties, expressed or implied, nor authorizes any other party to offer any warranty, including any implied warranties of merchantability or fitness for a particular purpose. Any implied warranties that may be imposed by law are limited to the terms of this limited warranty. This warranty statement supercedes all previous warranties.

#### Trademark Information

*All brand names, product names, and trademarks are the sole property of their respective owners. Windows is a registered trademark of Microsoft Corporation. Windows95/98/Me/XP and WindowsNT/2000 are trademarks of Microsoft Corporation.*



---

**Crestron Electronics, Inc.**  
15 Volvo Drive Rockleigh, NJ 07647  
Tel: 888.CRESTRON  
Fax: 201.767.7576  
[www.crestron.com](http://www.crestron.com)

**Installation Guide – DOC. 6296**  
**09.04**

Specifications subject to  
change without notice.