

Crestron **BB-5000**

Back Box

---

Installation Guide



**CRESTRON**

This document was prepared and written by the Technical Documentation department at:



Crestron Electronics, Inc.  
15 Volvo Drive  
Rockleigh, NJ 07647  
1-888-CRESTRON

# Contents

<b>Back Box: BB-5000</b>	<b>1</b>
Description.....	1
Installation .....	2
Construction Method .....	2
Post-Construction Method.....	4
Further Inquiries .....	6
Future Updates.....	7
Cutout Detail of Supplied Template .....	8
Return and Warranty Policies .....	9
Merchandise Returns / Repair Service .....	9
CRESTRON Limited Warranty.....	9



# Back Box: BB-5000

## Description

The back box, BB-5000, is the mounting hardware that secures either a Crestron Series 4500 or Series 5000 Lectern/Wall Mount Touchpanel to a wall or other suitable mounting surface.

*Supplied Components*

DESCRIPTION	PART NUMBER	QUANTITY
Metal Electrical Box with 8 knockouts	AY17465-1	1
Metal Mounting Bracket	MTBK02528-1	2
Metal Mounting Plate	MTPL02523-1	2
Screw, 6-32 x 1"L, pan, phillips, black	SR06-32-1R000-3	12
Screw, 6-32 x 1/2"L, pan, phillips, zinc	SR06-32-0R5000-4	6
Template	OV40050-1	1

Three views and dimensions for the metal pieces of the BB-5000 are shown below.

*BB-5000 Physical Views and Dimensions*

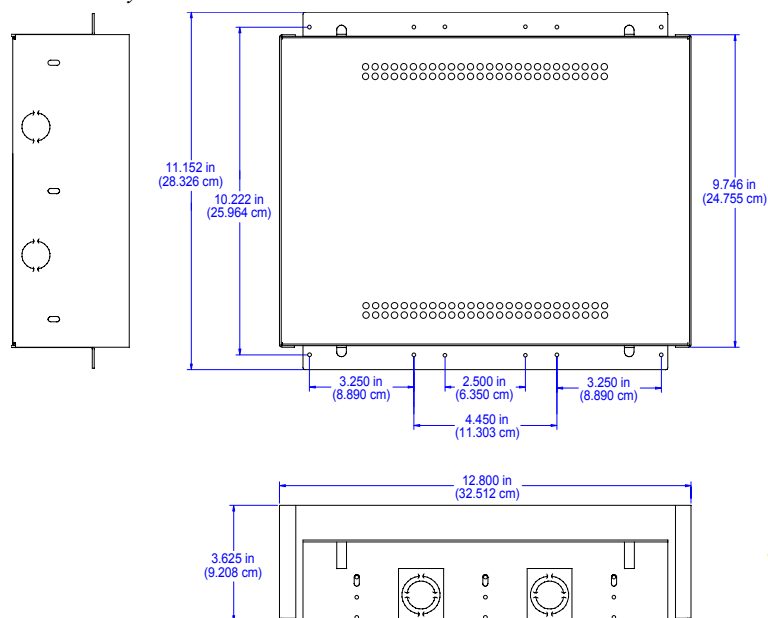

## Installation

There are at least two different methods of installing the BB-5000. The construction method is initiated during the construction process. Use this method to wall mount either a Crestron Series 4500 or Series 5000 Lectern/Wall Mount Touchpanel to a wall stud. Installation begins at a time when the rooms in which the panel is to be installed are framed and the gypsum board has not been hung. The post-construction method is preferred for wall mounting when the rooms are complete and the gypsum board has already been hung. The post-construction method is also desirable when lectern mounting the panel.

### Construction Method

The only equipment and tools required are three #6 mounting screws (or equivalent), a drill with adjustable torque, a #2 Phillips tip bit, a 5/16" drill bit, and a #20 drill bit. Complete the following installation procedure in the order provided.

1. Remove necessary knockout(s) from metal electrical box.
2. Use six pan head screws (1/2" length), supplied, to loosely secure two metal brackets to the back box.

*Attaching Two Metal Brackets to the Back Box*

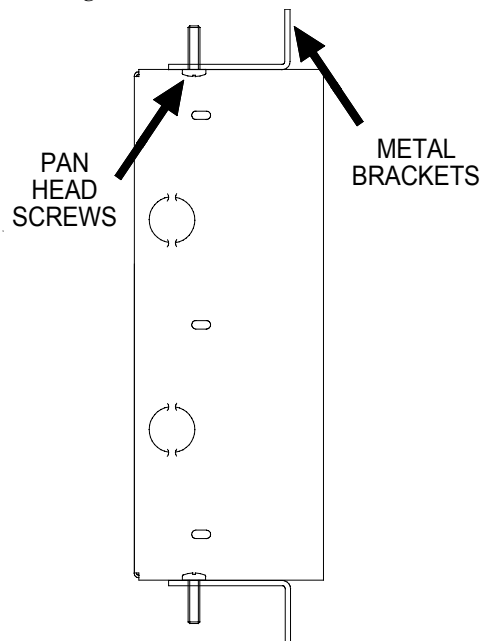

3. Position the metal electrical box to the stud. If  $\frac{5}{8}$ " gypsum board is used, be sure that  $\frac{1}{2}$ " of the box protrudes from the stud as illustrated in the metal electrical box cut away shown after this step.

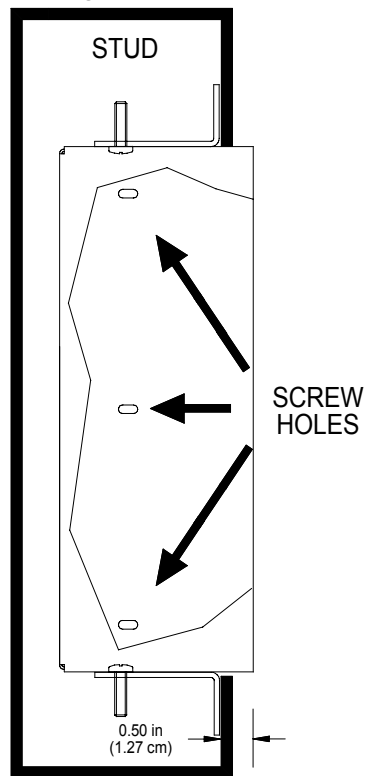
*Securing Metal Electrical Box to Stud*

4. Use three #6 screws, not supplied, to secure metal electrical box to the stud.
5. Pull Cresnet wire through open knockout(s) in the metal electrical box.

---

**NOTE:** Wait for gypsum board to be hung before continuing with remainder of construction method installation.

---

6. Fasten template, supplied, to mounting surface; cut out and remove the traced shape.
7. Drill four 5/16" holes as marked on template. Only drill through gypsum board. Use caution and do not drill through metal bracket that rests behind gypsum board. Refer to "Cutout Detail of Supplied Template" on page 8 for an illustrative reference.
8. Drill 12 holes marked "A" on template with #20 bit. Only drill through gypsum board. Use caution and do not drill through metal bracket that rests behind gypsum board. Refer to "Cutout Detail of Supplied Template" on page 8 for an illustrative reference.
9. Position one metal mounting plate along the top horizontal edge so that it covers the two center holes marked "A".
10. Use two pan head screws (1" length), supplied, to loosely secure the bracket and plate to the mounting surface.
11. Position one metal mounting plate along the bottom horizontal edge so that it covers the two center holes marked "A".
12. Use two pan head screws (1" length), supplied, to loosely secure the bracket and plate to the mounting surface.

13. Tighten four screws installed in steps 10 and 12 by hand. Be careful not to crack gypsum board.
14. Verify that the rim of the back box is recessed approximately 1/8" from the mounting surface and tighten six screws installed in step 2 with a torque of 11 in-lbs (1.243 N\*m).
15. If touchpanel is available, secure touchpanel to BB-5000 using eight pan head screws (1" length), supplied. Tighten screws by hand being careful not to crack gypsum board.

## Post-Construction Method

The only tools required are a gypsum board saw (or equivalent), a drill with adjustable torque, a #2 Phillips tip bit, a 5/16" bit, and a #20 bit. Complete the following installation procedure in the order provided.

1. Locate an area on the wall or other suitable mounting surface that is clear of studs, wires, and other obstructions.
2. Make a small hole near the middle of the designated site; verify location is suitable.
3. Fasten cutout template, supplied, to mounting surface; verify that the template is level.
4. Cut out and remove the traced shape of mounting surface.
5. Drill four 5/16" holes as marked on template. Refer to "Cutout Detail of Supplied Template" on page 8 for an illustrative reference.
6. Drill 12 holes marked "A" on template with #20 bit. Refer to "Cutout Detail of Supplied Template" on page 8 for an illustrative reference.
7. Slide one metal mounting bracket through the opening and position it inside along the top horizontal edge.
8. Position one metal mounting plate along the top horizontal edge so that it covers the two center holes marked "A".
9. Use two pan head screws (1" length), supplied, to secure the bracket and plate to the mounting surface. Tighten by hand; do not fully tighten screws.



*Securing Bracket/Plate Assembly to Top and Bottom Edges of Opening*

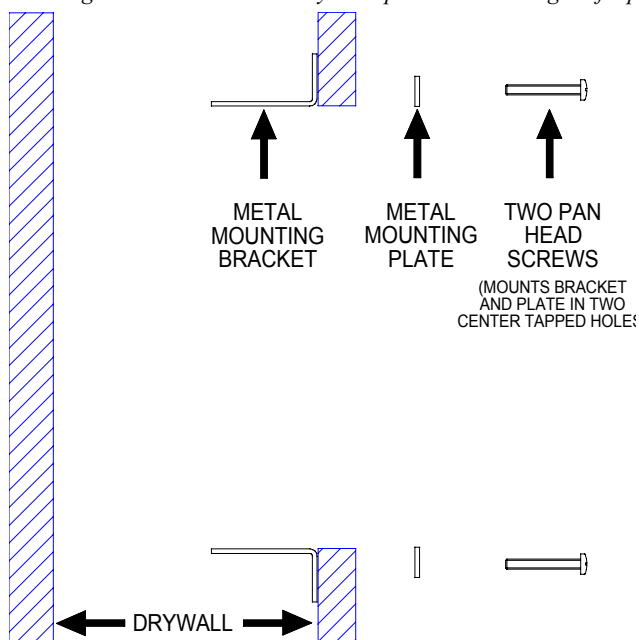

10. Repeat steps 7 through 9 for the bottom horizontal edge of the opening.
11. Remove necessary knockout(s) from metal electrical box.
12. Pull Cresnet wire through open knockout(s) in metal electrical box.
13. Slide the electrical back box through the opening until the rim of the back box is flush with the mounting surface.

---

**NOTE:** Do not slide the back box too far into the opening or it may fall in between the gypsum board (e.g., if installation is into an exterior wall).

---

*Positioning Back Box into Opening*

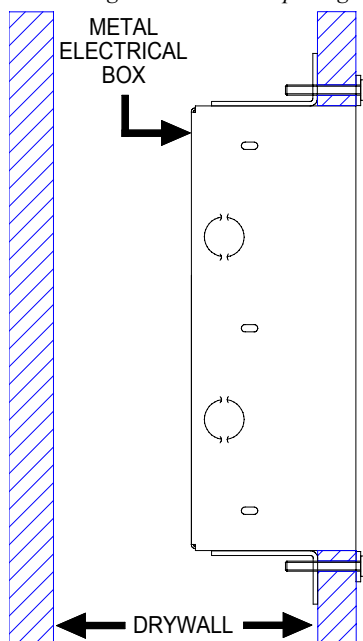

14. Tighten four screws installed in steps 9 and 10 by hand. Be careful not to crack gypsum board.
15. Use six pan head screws (1/2" length), supplied, to loosely secure the back box to the bracket plate assembly.

*Securing Back Box to Bracket/Plate Assembly*

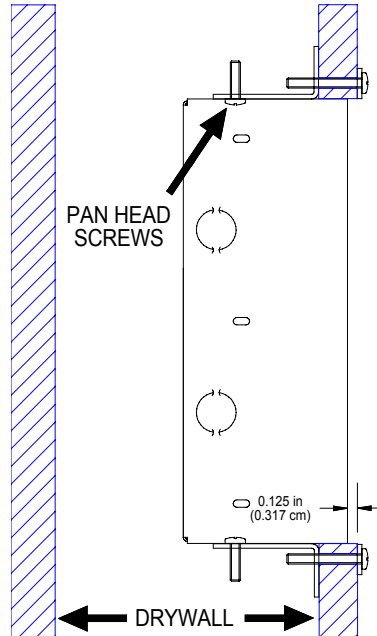

16. Verify that the rim of the back box is recessed approximately 1/8" from the mounting surface before tightening the six pan head screws with a torque of 11 in-lbs (1.243 N\*m).
17. If touchpanel is available, secure touchpanel to BB-5000 using eight pan head screws (1" length), supplied. Tighten screws by hand being careful not to crack gypsum board.

---

## Further Inquiries

If after reviewing this Installation Guide for the BB-5000, you cannot locate specific information or have questions, please take advantage of Crestron's award winning customer service team by calling:

- In the US and Canada, call Crestron's corporate headquarters at 1-888-CRESTRON [1-888-273-7876] or 1-201-767-3400
- In Europe, call Crestron International at +32-15-50-99-50
- In Asia, call Crestron Asia at +852-2341-2016
- In Latin America, call Crestron Latin America at +5255-5093-2160
- In Australia and New Zealand, call Creston Pacific at +613-9480-2999

## Future Updates

As Crestron improves functions, adds new features, and extends the capabilities of the BB-5000, additional information may be made available as manual updates. These updates are solely electronic and serve as intermediary supplements prior to the release of a complete technical documentation revision.

Check the Crestron website ([www.crestron.com](http://www.crestron.com)) periodically for manual update availability and its subjective value. Updates are available from the Downloads | Product Manuals section and are identified as an “Addendum” in the Download column.

## Cutout Detail of Supplied Template

Use the alphanumeric codes in the illustration and tables to obtain the cutout dimensions for the BB-5000. However, Crestron recommends that the supplied template be used to avoid error.

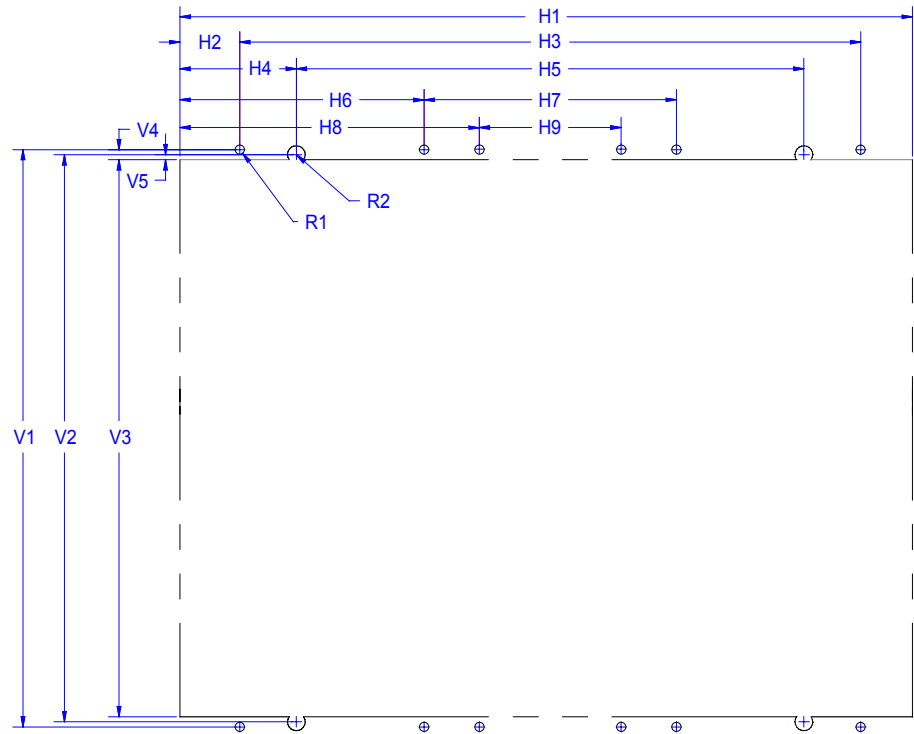

HORIZONTAL MEASUREMENTS	
H1	= 12.920 in (32.817 cm)
H2	= 1.056 in (2.682 cm)
H3	= 10.951 in (27.816 cm)
H4	= 2.054 in (5.217 cm)
H5	= 8.953 in (22.741 cm)
H6	= 4.305 in (10.935 cm)
H7	= 4.452 in (11.308 cm)
H8	= 5.282 in (13.416 cm)
H9	= 2.500 in (6.350 cm)

VERTICAL MEASUREMENTS	
V1	= 10.223 in (25.966 cm)
V2	= 10.043 in (25.509 cm)
V3	= 9.866 in (25.060 cm)
V4	= 0.179 in (0.455 cm)
V5	= 0.089 in (0.226 cm)

RADIUS MEASUREMENTS	
R1	= 0.161 in (0.409 cm) typical
R2	= 0.312 in (0.792 cm) typical

---

## Return and Warranty Policies

### Merchandise Returns / Repair Service

1. No merchandise may be returned for credit, exchange, or service without prior authorization from CRESTRON. To obtain warranty service for CRESTRON products, contact the factory and request an RMA (Return Merchandise Authorization) number. Enclose a note specifying the nature of the problem, name and phone number of contact person, RMA number, and return address.
2. Products may be returned for credit, exchange, or service with a CRESTRON Return Merchandise Authorization (RMA) number. Authorized returns must be shipped freight prepaid to CRESTRON, Cresskill, N.J., or its authorized subsidiaries, with RMA number clearly marked on the outside of all cartons. Shipments arriving freight collect or without an RMA number shall be subject to refusal. CRESTRON reserves the right in its sole and absolute discretion to charge a 15% restocking fee, plus shipping costs, on any products returned with an RMA.
3. Return freight charges following repair of items under warranty shall be paid by CRESTRON, shipping by standard ground carrier. In the event repairs are found to be non-warranty, return freight costs shall be paid by the purchaser.

### CRESTRON Limited Warranty

CRESTRON ELECTRONICS, Inc. warrants its products to be free from manufacturing defects in materials and workmanship under normal use for a period of three (3) years from the date of purchase from CRESTRON, with the following exceptions: disk drives and any other moving or rotating mechanical parts, pan/tilt heads and power supplies are covered for a period of one (1) year; touchscreen display and overlay components are covered for 90 days; batteries and incandescent lamps are not covered.

This warranty extends to products purchased directly from CRESTRON or an authorized CRESTRON dealer. Purchasers should inquire of the dealer regarding the nature and extent of the dealer's warranty, if any.

CRESTRON shall not be liable to honor the terms of this warranty if the product has been used in any application other than that for which it was intended, or if it has been subjected to misuse, accidental damage, modification, or improper installation procedures. Furthermore, this warranty does not cover any product that has had the serial number altered, defaced, or removed.

This warranty shall be the sole and exclusive remedy to the original purchaser. In no event shall CRESTRON be liable for incidental or consequential damages of any kind (property or economic damages inclusive) arising from the sale or use of this equipment. CRESTRON is not liable for any claim made by a third party or made by the purchaser for a third party.

CRESTRON shall, at its option, repair or replace any product found defective, without charge for parts or labor. Repaired or replaced equipment and parts supplied under this warranty shall be covered only by the unexpired portion of the warranty.

Except as expressly set forth in this warranty, CRESTRON makes no other warranties, expressed or implied, nor authorizes any other party to offer any other party to offer any warranty, including any implied warranties of merchantability or fitness for a particular purpose. Any implied warranties that may be imposed by law are limited to the terms of this limited warranty. This warranty statement supercedes all previous warranties.

#### Trademark Information

*All brand names, product names, and trademarks are the sole property of their respective owners. Windows is a registered trademark of Microsoft Corporation. Windows95/98/Me/XP and WindowsNT/2000 are trademarks of Microsoft Corporation.*

This page intentionally left blank.

This page intentionally left blank.



---

**Crestron Electronics, Inc.**  
15 Volvo Drive Rockleigh, NJ 07647  
Tel: 888.CRESTRON  
Fax: 201.767.7576  
[www.crestron.com](http://www.crestron.com)

**Installation Guide – DOC. 5827A**  
**05.02**

Specifications subject to  
change without notice.