

Crestron **CSC-BRKT-1G**  
 Mounting Bracket for Shade Interface  
 Installation Guide



**Further Inquiries**

To locate specific information or resolve questions after reviewing this guide, contact Crestron's True Blue Support at 1-888-CRESTRON [1-888-273-7876] or refer to the listing of Crestron worldwide offices on the Crestron Web site ([www.crestron.com/offices](http://www.crestron.com/offices)) for assistance within a particular geographic region.

To post a question about Crestron products, log onto the Online Help section of the Crestron Web site ([www.crestron.com/onlinehelp](http://www.crestron.com/onlinehelp)). First-time users must establish a user account to fully benefit from all available features.

**Future Updates**

As Crestron improves functions, adds new features and extends the capabilities of the CSC-BRKT-1G, additional information may be made available as manual updates. These updates are solely electronic and serve as intermediary supplements prior to the release of a complete technical documentation revision.

Check the Crestron Web site periodically for manual update availability and its relevance. Updates are identified as an "Addendum" in the Download column.

**WARNING:** To avoid fire, shock, or death; turn off power at circuit breaker or fuse and test that power is off before wiring!

**NOTES:** Observe the following points.

- To be installed and/or used in accordance with appropriate electrical codes and regulations.
- This product should be installed by a qualified electrician.

**Crestron Electronics, Inc.**  
 15 Volvo Drive Rockleigh, NJ 07647  
 Tel: 888.CRESTRON  
 Fax: 201.767.7576  
[www.crestron.com](http://www.crestron.com)

**Installation Guide - DOC. 7353A**  
**(2033159)**  
**06.12**  
 Specifications subject to  
 change without notice.

**INTRODUCTION**

The Crestron® CSC-BRKT-1G allows a CSC-ACEX, CSC-ACCN, CSC-DCEX or CSC-DCCN interface (all sold separately) to be mounted inside a single gang wall box and still maintain the ability to program and operate the interface.

**Physical Description**

This section provides information on the dimensions for the CSC-BRKT-1G.

**Dimensional Drawing**

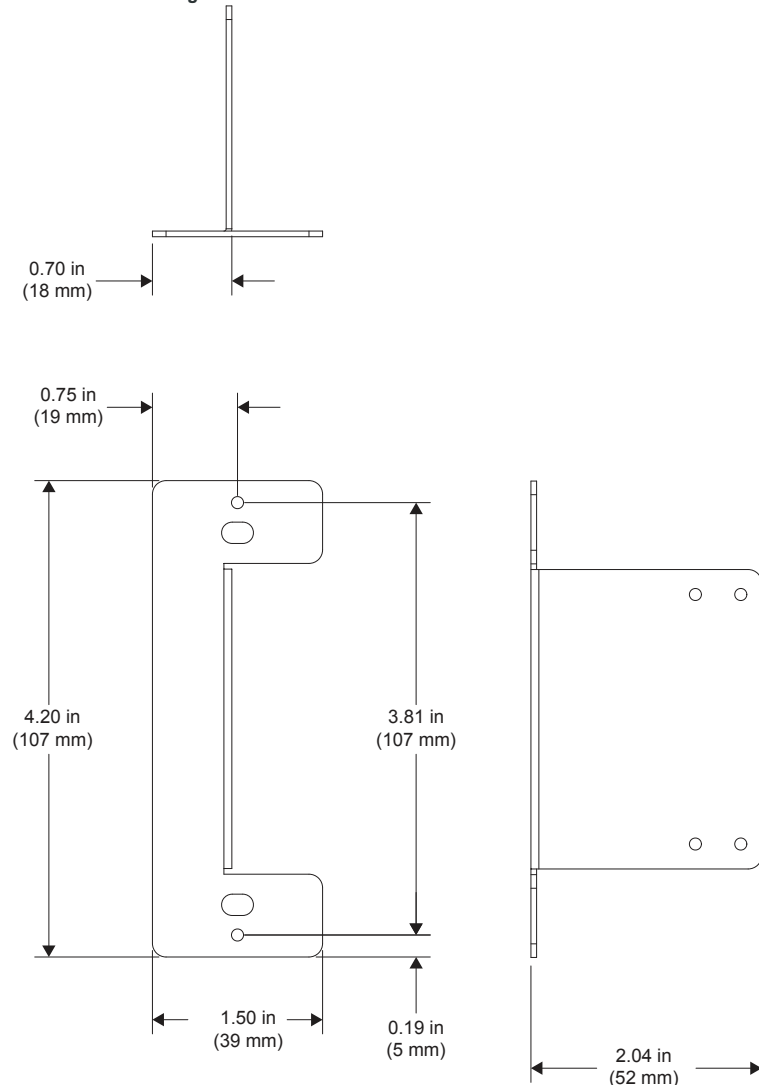

## MOUNTING

Follow the procedure below to assemble the CSC-ACEX, CSC-ACCN, CSC-DCEX or CSC-DCCN interface with the CSC-BRKT-1G. Refer to the illustration that follows for visual guidance.

1. Using the two supplied phillips head screws attach the interface to the bracket so that the **UP**, **SET** and **DN** buttons face the angled portion of the bracket.
2. (Optional) Make power connection to the rear of the CSC-DCEX.
3. Using the two supplied phillips head screws, install the bracket into the single gang box.
4. Attach a decora style faceplate.

### Assembly CSC-BRKT-1G to Single Gang Box - CSC-ACEX Interface Shown

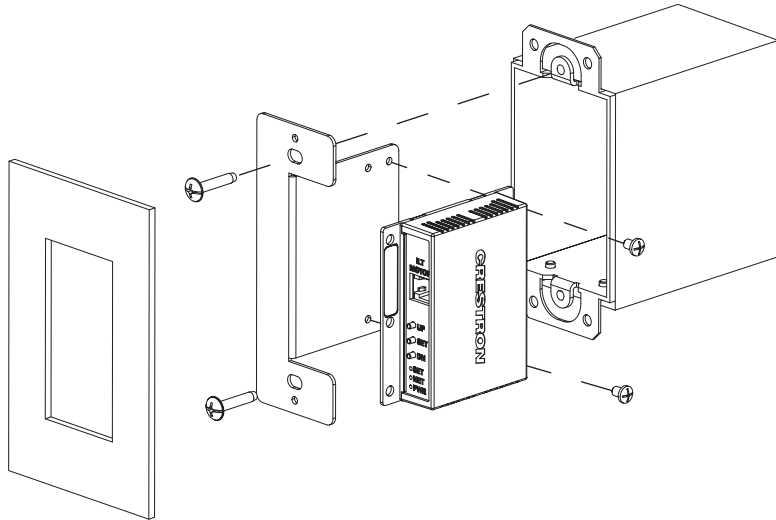

## Return and Warranty Policies

### Merchandise Returns / Repair Service

1. No merchandise may be returned for credit, exchange or service without prior authorization from Crestron. To obtain warranty service for Crestron products, contact an authorized Crestron dealer. Only authorized Crestron dealers may contact the factory and request an RMA (Return Merchandise Authorization) number. Enclose a note specifying the nature of the problem, name and phone number of contact person, RMA number and return address.
2. Products may be returned for credit, exchange or service with a Crestron Return Merchandise Authorization (RMA) number. Authorized returns must be shipped freight prepaid to Crestron, 6 Volvo Drive, Rockleigh, N.J. or its authorized subsidiaries, with RMA number clearly marked on the outside of all cartons. Shipments arriving freight collect or without an RMA number shall be subject to refusal. Crestron reserves the right in its sole and absolute discretion to charge a 15% restocking fee plus shipping costs on any products returned with an RMA.
3. Return freight charges following repair of items under warranty shall be paid by Crestron, shipping by standard ground carrier. In the event repairs are found to be non-warranty, return freight costs shall be paid by the purchaser.

### Crestron Limited Warranty

Crestron Electronics, Inc. warrants its products to be free from manufacturing defects in materials and workmanship under normal use for a period of three (3) years from the date of purchase from Crestron, with the following exceptions: disk drives and any other moving or rotating mechanical parts, pan/tilt heads and power supplies are covered for a period of one (1) year; touch screen display and overlay components are covered for 90 days; batteries and incandescent lamps are not covered. This warranty extends to products purchased directly from Crestron or an authorized Crestron dealer. Purchasers should inquire of the dealer regarding the nature and extent of the dealer's warranty, if any.

Crestron shall not be liable to honor the terms of this warranty if the product has been used in any application other than that for which it was intended or if it has been subjected to misuse, accidental damage, modification or improper installation procedures. Furthermore, this warranty does not cover any product that has had the serial number altered, defaced or removed.

This warranty shall be the sole and exclusive remedy to the original purchaser. In no event shall Crestron be liable for incidental or consequential damages of any kind (property or economic damages inclusive) arising from the sale or use of this equipment. Crestron is not liable for any claim made by a third party or made by the purchaser for a third party.

Crestron shall, at its option, repair or replace any product found defective, without charge for parts or labor. Repaired or replaced equipment and parts supplied under this warranty shall be covered only by the unexpired portion of the warranty.

Except as expressly set forth in this warranty, Crestron makes no other warranties, expressed or implied, nor authorizes any other party to offer any warranty, including any implied warranties of merchantability or fitness for a particular purpose. Any implied warranties that may be imposed by law are limited to the terms of this limited warranty. This warranty statement supersedes all previous warranties.

The specific patents that cover Crestron products are listed at [patents.crestron.com](http://patents.crestron.com).

Crestron and the Crestron logo are either trademarks or registered trademarks of Crestron Electronics, Inc. in the United States and/or other countries. Other trademarks and trade names may be used in this document to refer to either the entities claiming the marks and names or their products. Crestron disclaims any proprietary interest in the marks and names of others.  
©2012 Crestron Electronics, Inc.