

Introduction

CRESTRON GREEN LIGHT EXPRESS power switching cabinets come pre-configured with GLXX switching modules already installed. The cabinets only require installation and wiring of feed and load circuits.

Regulatory Compliance

The cabinet and modules are Listed to applicable UL Standards and requirements by Underwriters Laboratories Inc.



Application

The following diagram shows CRESTRON GREEN LIGHT EXPRESS power switching cabinets in a lighting application that is controlled by an IPAC system.

CRESTRON GREEN LIGHT EXPRESS Power Switching Cabinets in a Typical Lighting Application

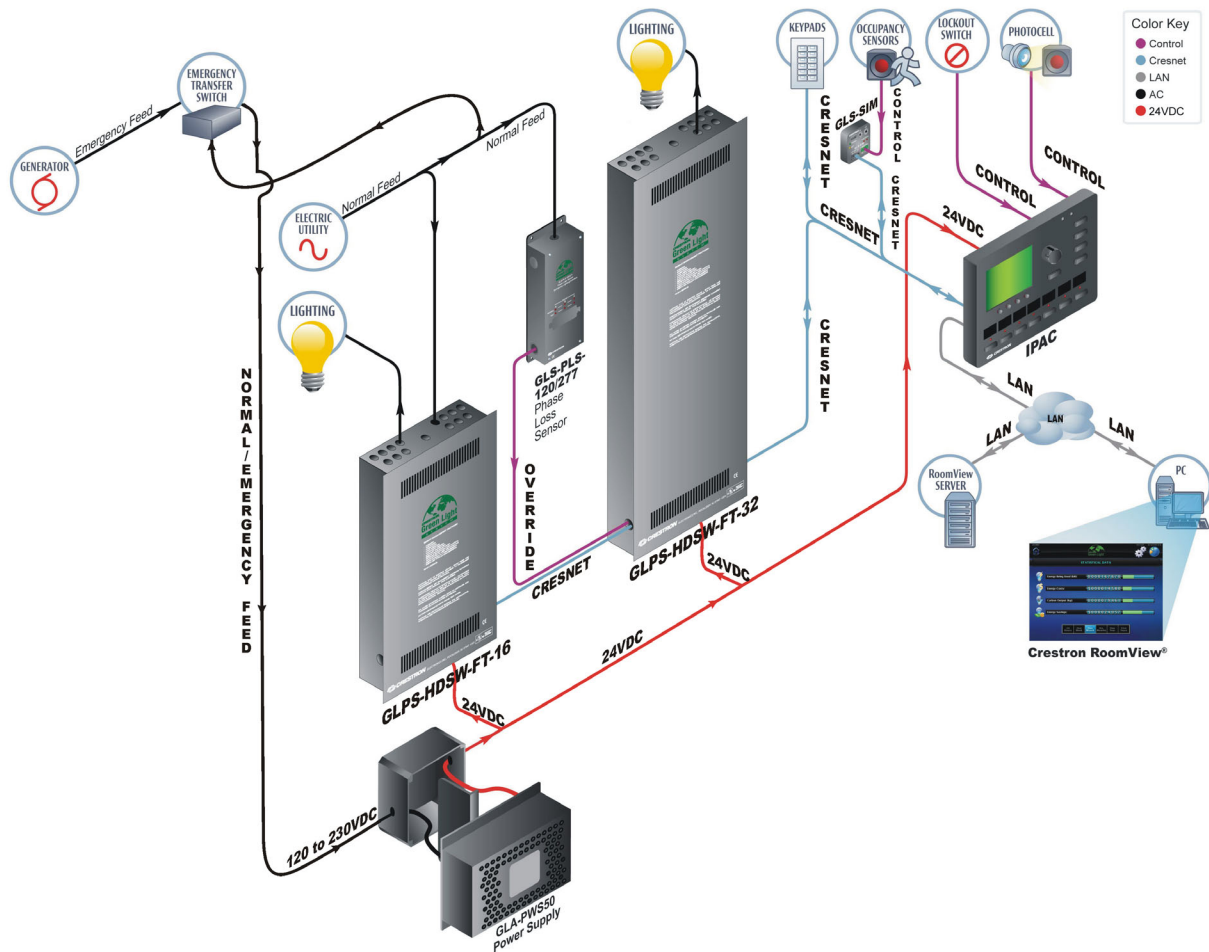

Physical Description

This section shows the dimensions of the CRESTRON GREEN LIGHT EXPRESS power switching cabinets.

Dimensions of GLPS-HDSW-FT-8, -12, -16, -20, -24 Power Switching Cabinets (Front, Side and Bottom View)

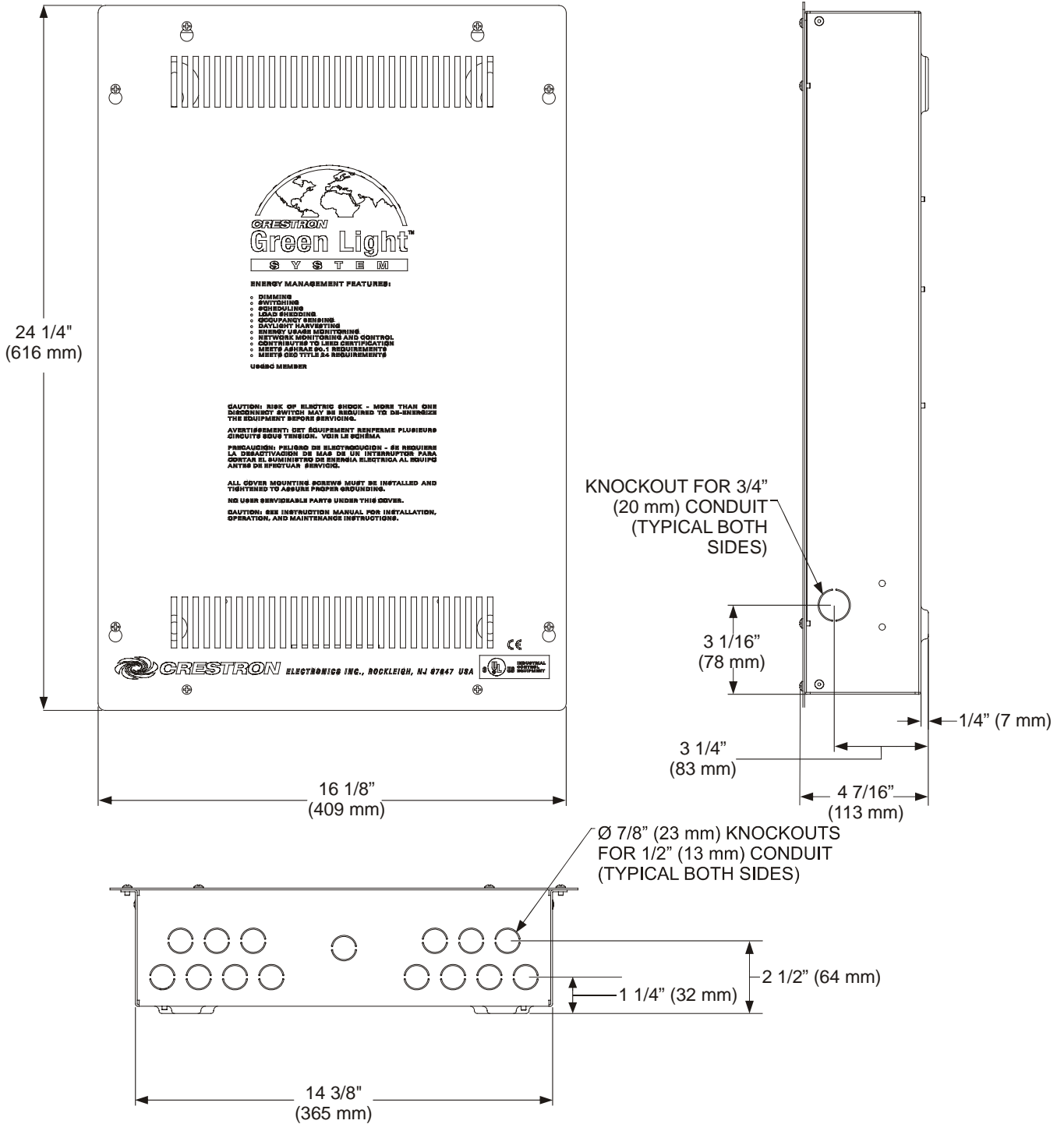

Dimensions of GLPS-HDSW-FT-8, -12, -16, -20, -24 (shown below) Power Switching Cabinets (Internal View)

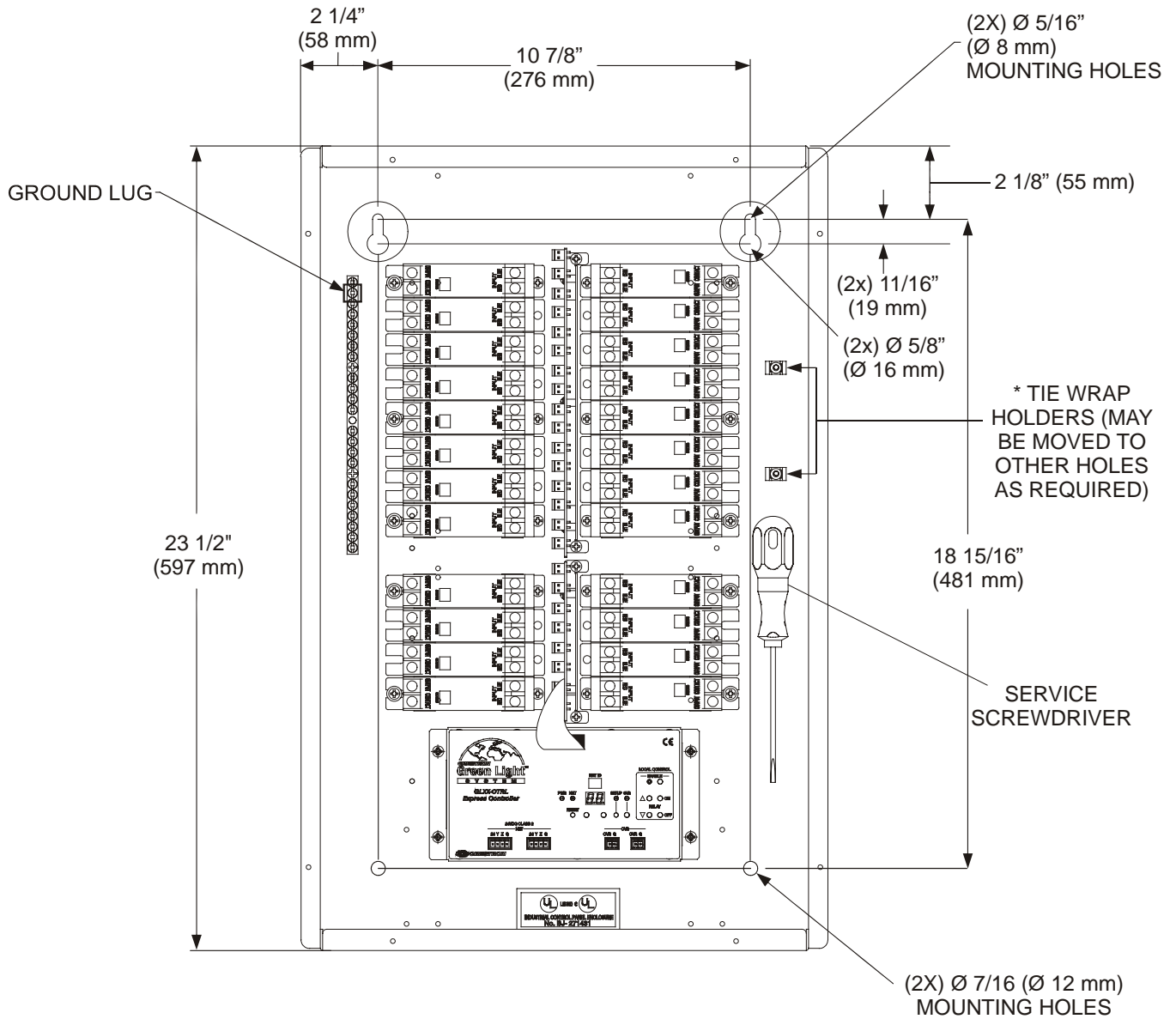

* Installed GLXX modules come with additional tie wrap holders.

Dimensions of GLPS-HDSW-FT-28, -32, -36, -40, -48, -52, -56 Power Switching Cabinets (Front, Side and Bottom View)

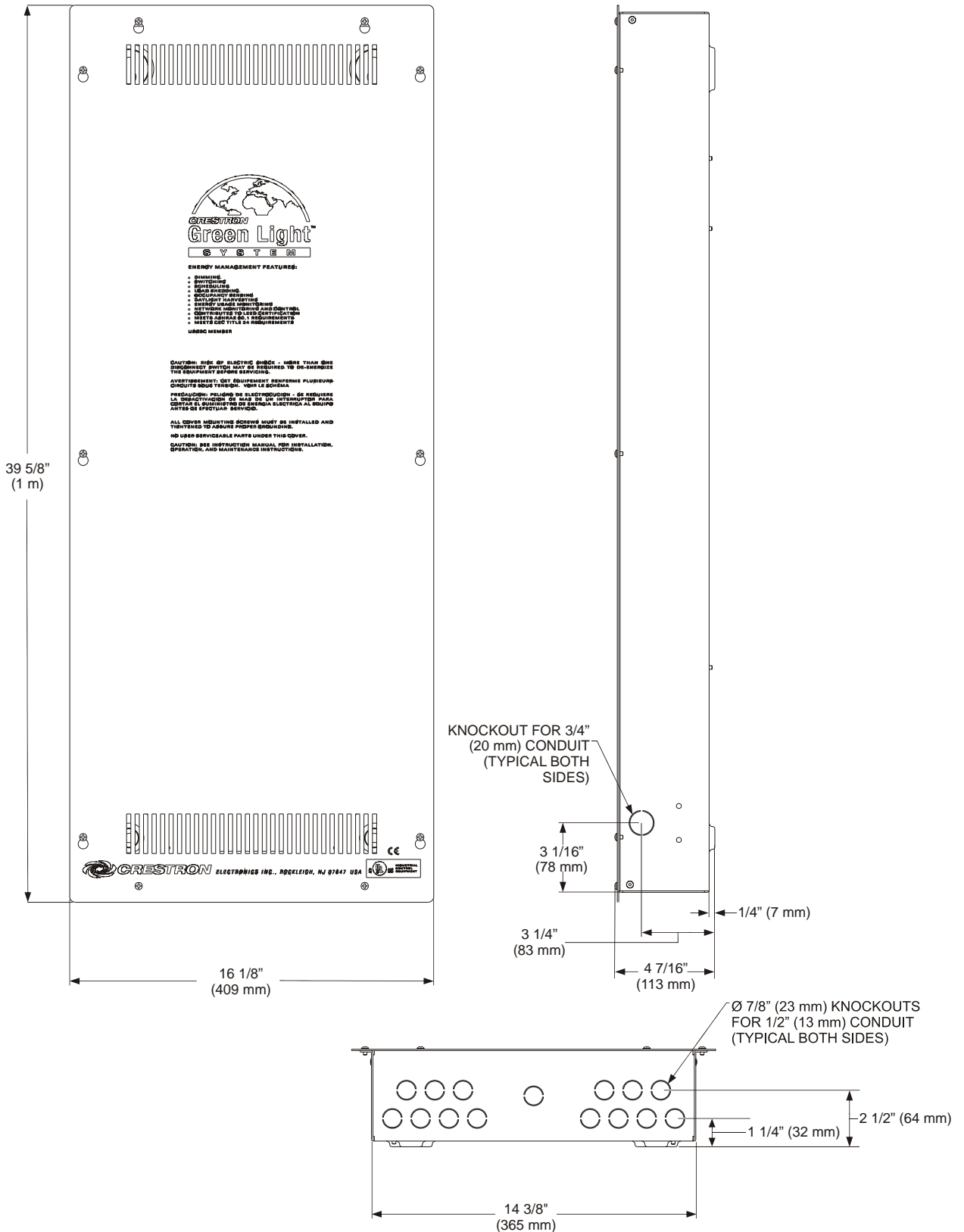

Dimensions of GLPS-HDSW-FT-28, -32, -36, -40, -48, -52, -56 (shown below) Power Switching Cabinets (Internal View)

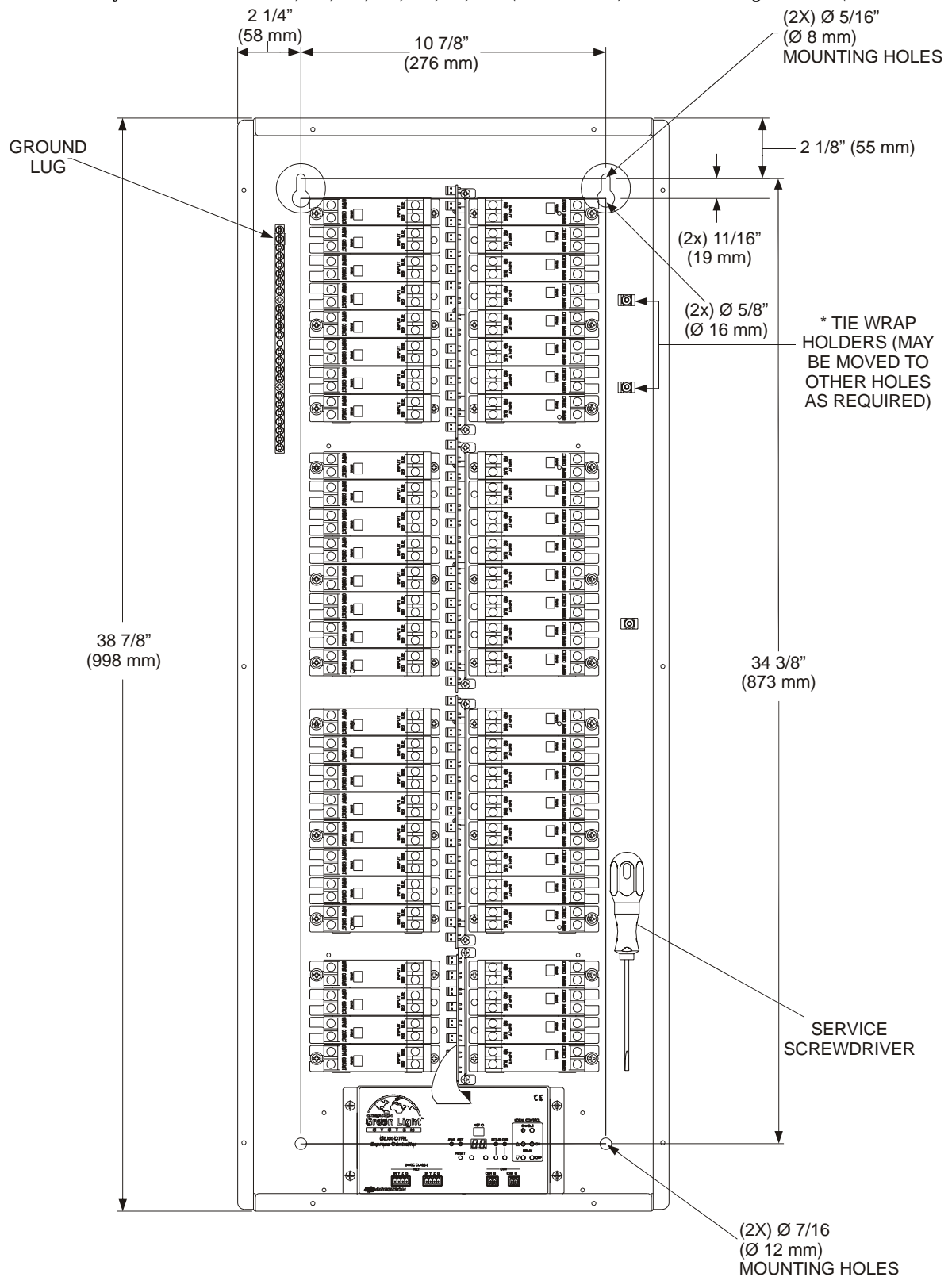

* Installed GLXX modules come with additional tie wrap holders.

Installation

Observe the following when installing the cabinet:

- The cabinet must be mounted by a licensed electrician in accordance with all national and local codes. Refer to the diagram below for specific requirements.
- The cabinet is designed for surface mounting on a wall.
- Cabinets are intended for indoor use only.
- The ambient temperature range should be 32°F to 104°F (0°C to 40°C). The relative humidity should range from 10% to 90% (non-condensing). Allow adequate clearance in front of the cover for servicing.

Mounting Location

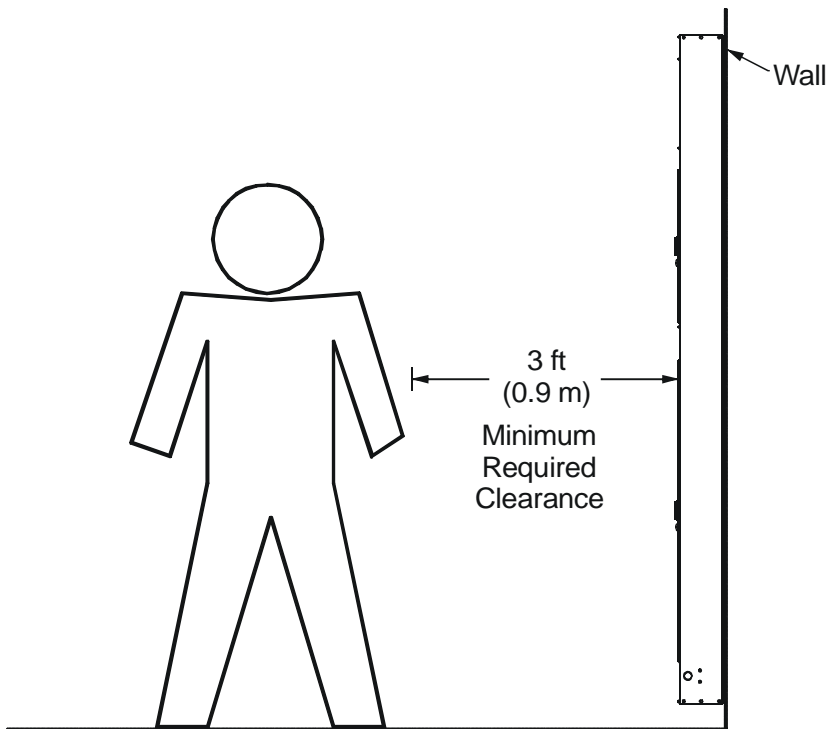

Wiring

NOTE: All wiring must be installed in accordance with all local and national electrical codes.

NOTE: Refer to the torque settings specified on pages 8 and 9.

CRESTRON GREEN LIGHT EXPRESS power switching cabinets come pre-configured with GLXX-HDSW switching modules already installed. The cabinets only require installation and wiring of feed and load circuits.

The following must be performed after mounting the cabinet:

- Connect incoming feed conductors to the input terminals and connect loads to contact terminals (section **A** of the following diagram)
- Connect control wiring (section **B** of the following diagram)

Feed-Through and Load Wiring

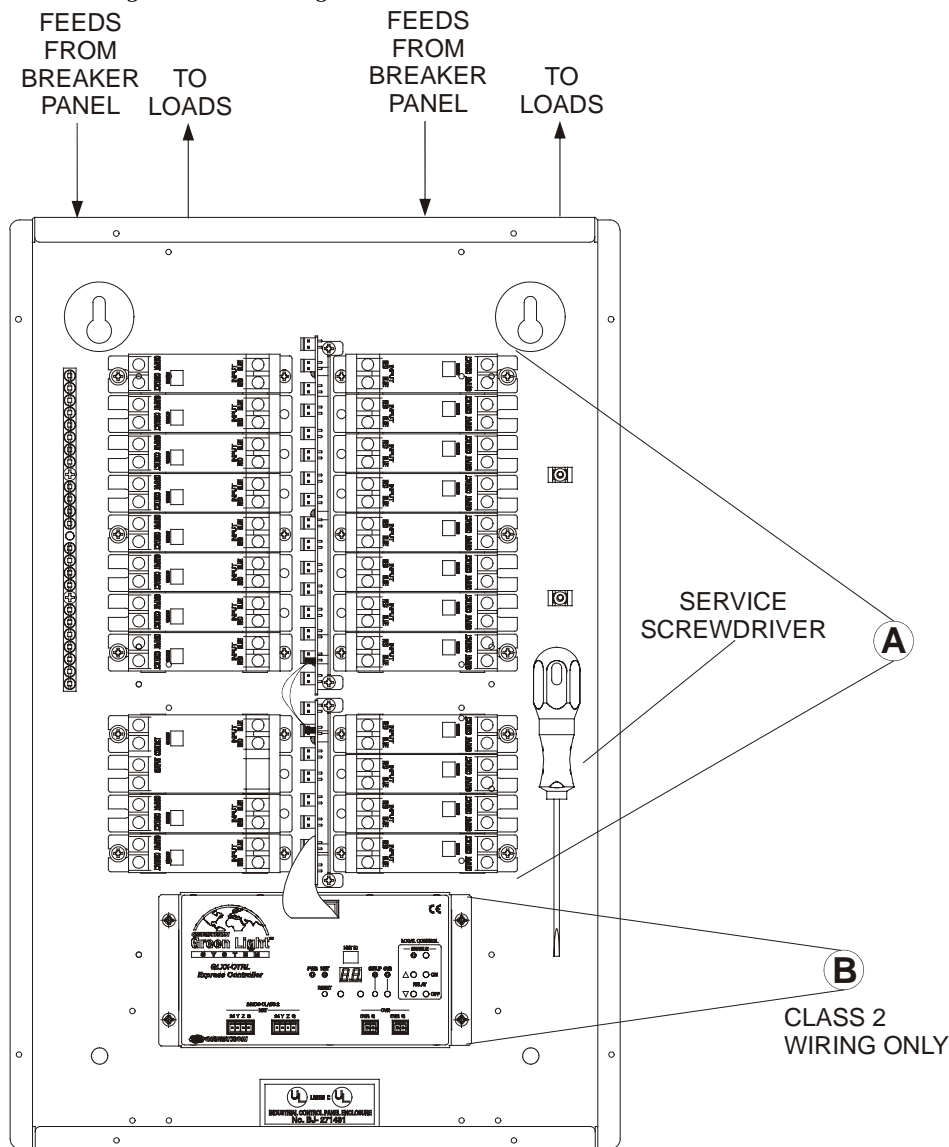

Feed-Through and Load Wiring (Section A)

NOTE: Use copper conductors only – rated 75°C.

Wire Gauge and Torque Values

TERMINAL	CONNECTOR MAX WIRE RANGE	TORQUE	STRIP LENGTH
INPUT	26-10 AWG	5.31 lb-in (0.6 Nm) to 7.08 lb-in (0.8 Nm) max	3/8" (9 mm)
OUTPUT/CONTACT	26-10 AWG	5.31 lb-in (0.6 Nm) to 7.08 lb-in (0.8 Nm) max	3/8" (9 mm)
GROUND LUG	14-4 AWG	25-45 lb-in (2.8-5.1 Nm)	3/4" (19 mm)

Load Wiring for GLXX-HDSW8 and GLXX-HDSW16

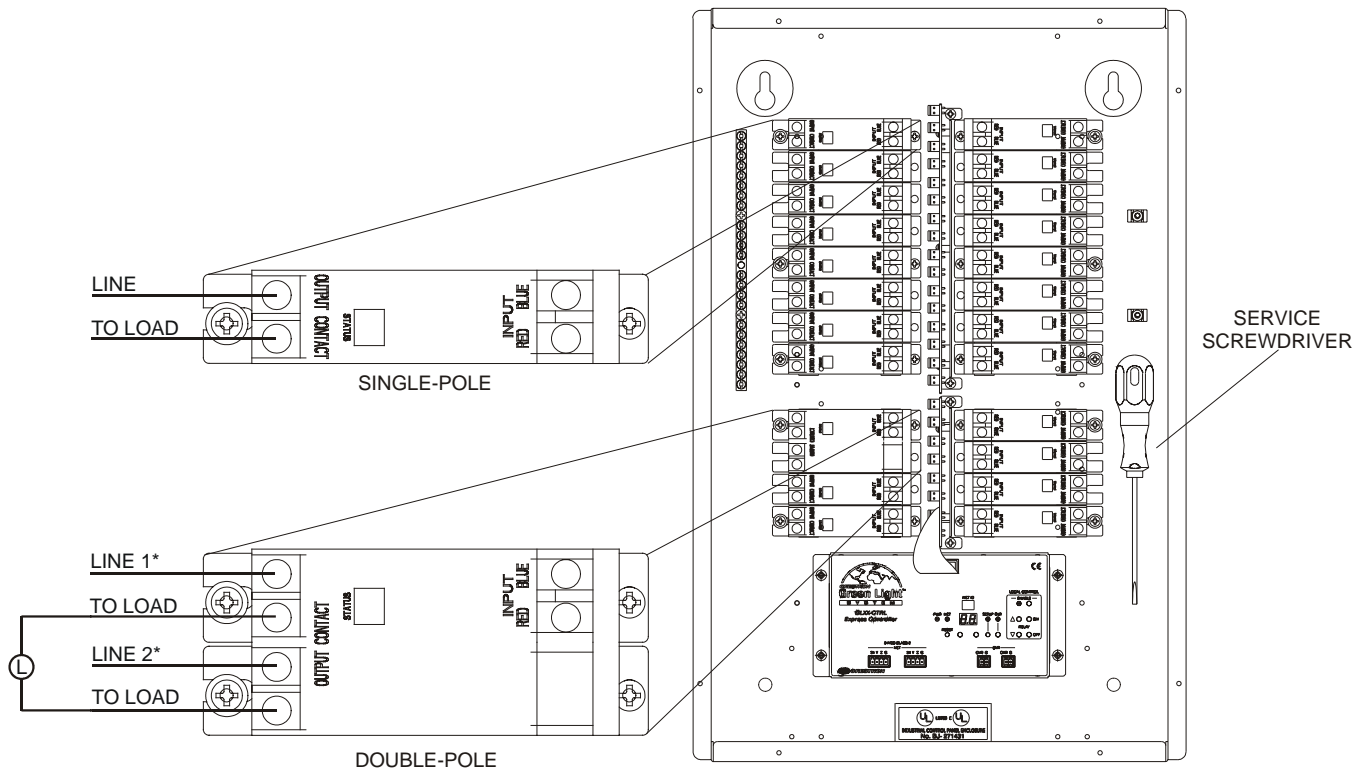

* Lines 1 and 2 must be on different phases.

NOTE: All GLXX-HDSW8 or GLXX-HDSW16 modules must be connected together in series to the GLXX-CNTRL Express Controller using the quick-connect jumper wires provided.

Control Wiring (Section B)

The bottom of the cabinet contains Cresnet® connections for interfacing to the rest of the Crestron® control system. It also provides overrides input which can be tied to devices such as the GLS-PLS-120/277 phase-loss sensor, or other devices that provide a dry contact closure (manual switch, fire alarm relay, etc.).

To ensure optimum performance over the full range of your installation topology, use Crestron certified wire. Failure to do so may incur additional charges if support is required to identify performance deficiencies because of using improper wire.

NOTE: Interface connectors for **NET** (x2), and **OVERRIDE** (x3) ports are provided.

Wire Gauge and Torque Values

TERMINAL	CONNECTOR MAX WIRE RANGE	TORQUE	STRIP LENGTH
NET	26-12 AWG	4.43 lb-in (0.5 Nm)	1/4" (6 mm)
OVERRIDE	26-12 AWG	4.43 lb-in (0.5 Nm)	1/4" (6 mm)

Connector Wiring

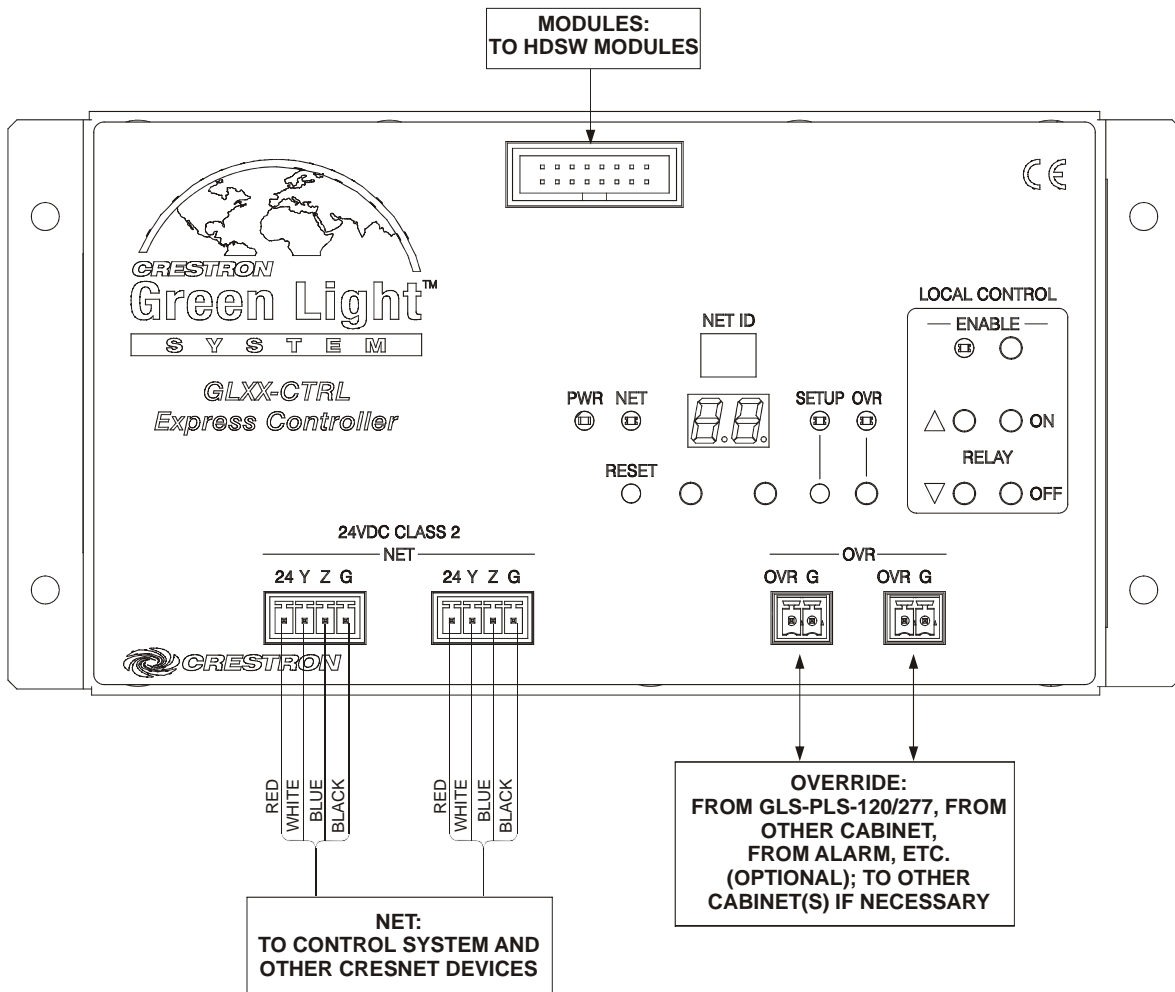

NOTE: For instructions on network wiring, refer to “Appendix C: Network Wiring” on page 18.

NET Port Wiring

When wiring the supplied **NET** connectors for connection to a Crestron control system or other device on the Cresnet network, use Crestron certified wire such as CRESNET-NP or CRESNET-P. For instructions on network wiring, refer to “Appendix C: Network Wiring” on page 18.

When daisy-chaining connections between **NET** ports, strip the ends of the wires carefully to avoid nicking the conductors. Twist together the ends of the wires that share a pin on the network connector, insert the connection into the Cresnet connector, tighten the retaining screw. Repeat the procedure for the other three conductors.

OVERRIDE Port Wiring

When a connection is applied between the override terminals, the modules will enter *Override* mode. The Crestron GLS-PLS-120/277 phase-loss sensor or any device that provides a dry contact closure can be connected to the supplied **OVERRIDE** connector on the bottom of the cabinet.

Mechanical Override

1. Locate the mechanical override rocker switch labeled **STATUS** on the top of the relay.

Mechanical Override Switch

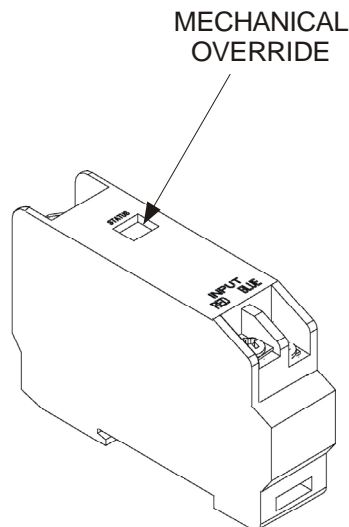

2. Place the tip of a screwdriver on the switch and push against the indentation.
3. The rocker switch will toggle into either an “ON or OFF” position, overriding the current state.

Relays

The GLXX-CTRL identifies relays in the sequential order in which they are introduced to the GLXX-HDSW. Relays come pre-installed from the factory. Install additional relays from left to right, starting the top of the cabinet and moving down. Refer to the illustration below.

Relay Installation Sequence

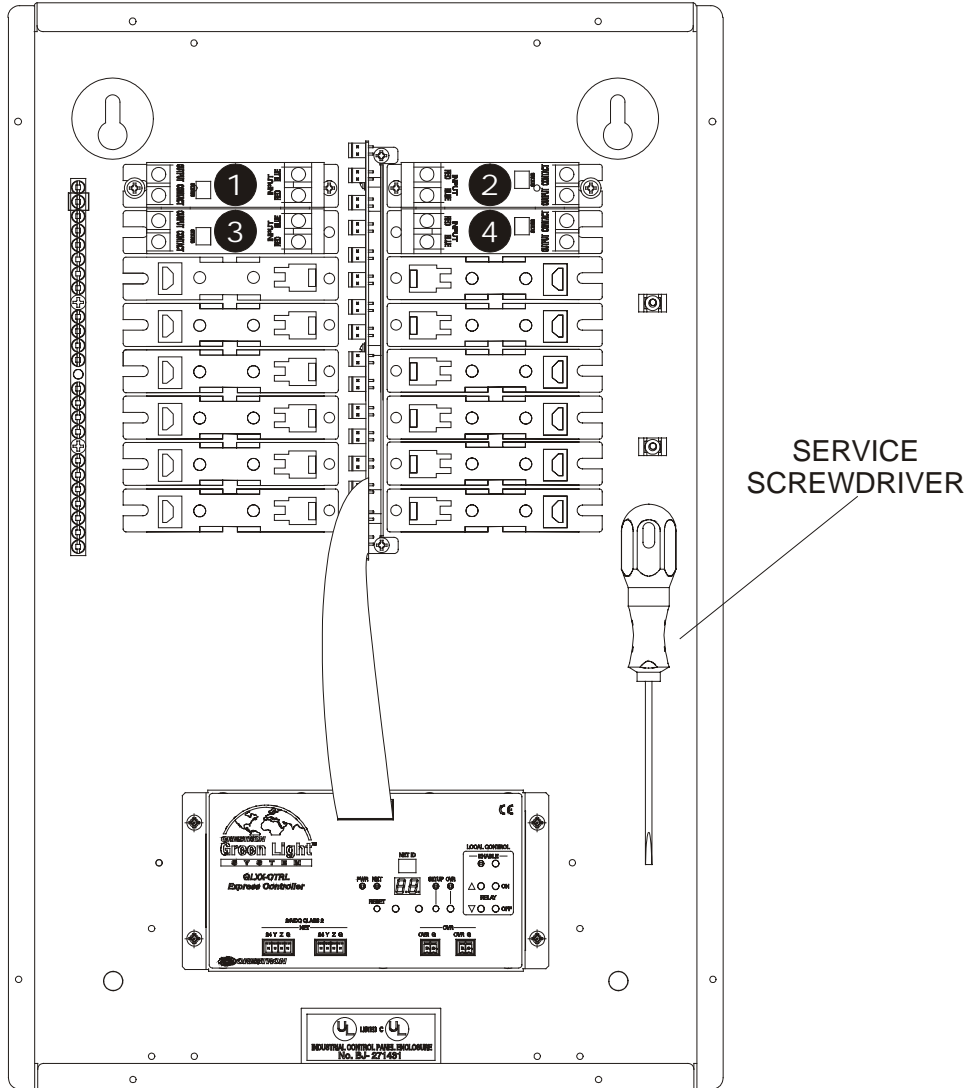

Relay Installation Procedure

1. Insert the output side of the relay into the tab(s) on the mounting strap.
2. Push down on the relay to lock the spring clips into the relay. Refer to the illustration below.

Inserting the relay into the mounting strap (Double Pole Relay Shown)

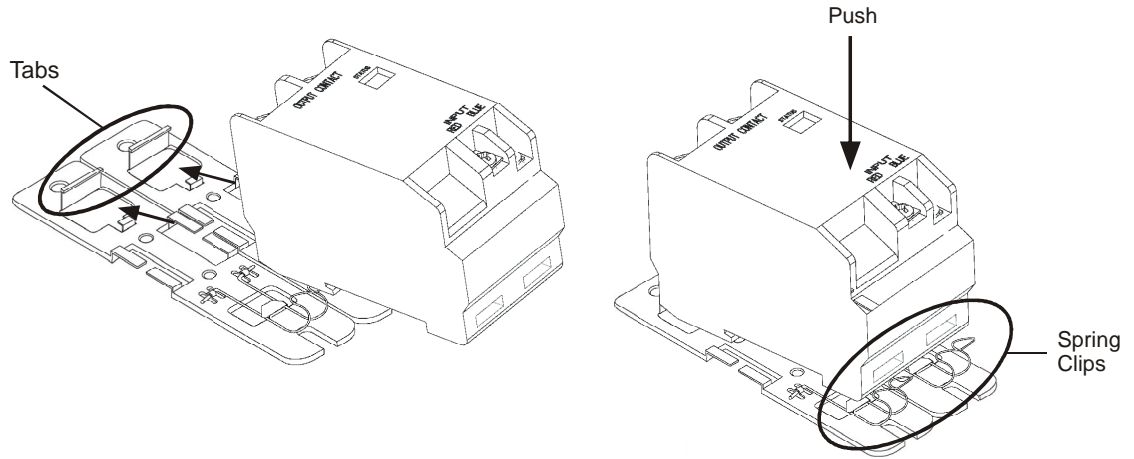

3. Attach the wiring connector on the relay to the GLXX-HDSW.

Connecting the Relay to the GLXX-HDSW (Single Pole Relay Shown)

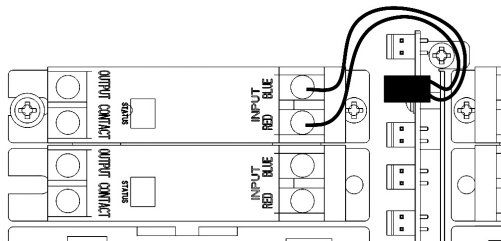

Relay Removal Procedure

1. Disconnect the wiring connector on the relay from the GLXX-HDSW.

Disconnecting the Relay from the GLXX-HDSW (Single Pole Relay Shown)

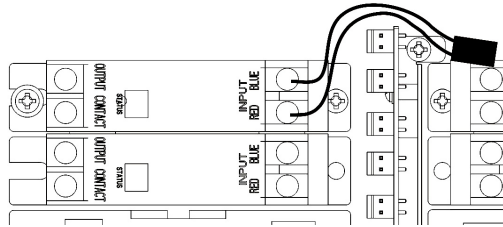

2. To release the relay from the mounting strap, press firmly on the spring clip(s).
3. Pull the relay away from the tabs and lift it out of the mounting strap

Removing the relay from the mounting strap (Double Pole Relay Shown)

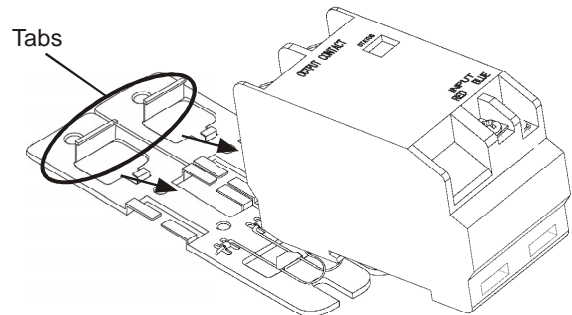
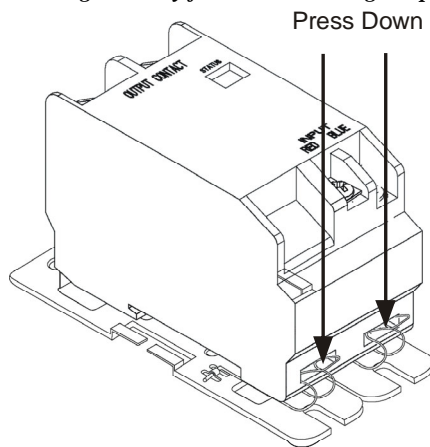

Testing

Manual Control

Lighting loads can be manually controlled from the front panel.

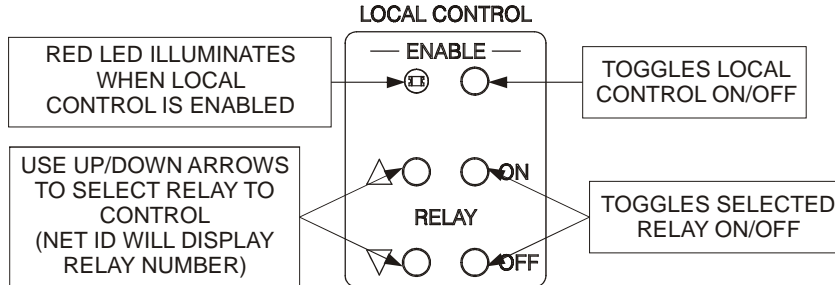

NOTE: To disable local control, press the **ENABLE** button again or wait for two minutes. The red LED beside the button will deactivate.

NOTE: The control system program may change the settings if the *Override* mode is not enabled.

Override Mode

The *Override* mode overrides the control system program and sets all of the output states to the stored override values. For instructions on saving override settings, refer to “Save Override Settings” below.

To enable *Override* mode, press and release the **OVR** button. The **OVR** LED flashes slowly.

NOTE: If the *Override* mode was enabled from an external device (i.e. a contact closure is present on the **OVERRIDE** terminals), the **OVR** LED will flash quickly. Pressing the **OVR** button has no effect.

To disable *Override* mode, press the **OVR** button again. The **OVR** LED extinguishes and the outputs return to the states set by the control system program.

NOTE: If override states have not been stored, the factory default override state is all loads on.

Save Override Settings

The state of each output can be saved as an override setting, which can be automatically recalled when the *Override* mode is enabled.

NOTE: The control system program has a setting that can prevent locally saving the override state. If this setting is enabled, the display shows “Er” when trying to save override states. For more information, refer to the SIMPL Windows help file.

To save the states of all outputs as the override setting, press and hold the **OVR** button for three seconds until the **OVR** LED blinks once.

System Operation and Commissioning

This cabinet has been designed as a component of a programmed Crestron system. System commissioning by an authorized Crestron representative **must** be performed to ensure system operation.

Once the cabinet has been wired and the modules have been tested, contact Crestron at 1-888-CRESTRON [1-888-273-7876] to schedule commissioning.

Problem Solving

Troubleshooting

The following table provides corrective action for possible trouble situations. If further assistance is required, please contact a Crestron customer service representative.

Troubleshooting

TROUBLE	POSSIBLE CAUSE(S)	CORRECTIVE ACTION
Module(s) does not function.	Device is not receiving power from a Crestron power source.	Verify connections.
	Device is not receiving sufficient power via Cresnet link.	Use the Crestron Power Calculator to help calculate how much power is needed for the system.
	System commissioning not complete.	Arrange for system commissioning.
Unit cannot be taken out of <i>Override</i> mode	Short (contact closure) exists between G and OVR terminals on any of the OVERRIDE terminals present at bottom of the cabinet.	Determine the reason for the short. Remove or remedy the short (e.g. GLS-PLS-120/277 phase-loss sensor may not have been installed properly, or actual phase-loss has been detected).

Further Inquiries

If you cannot locate specific information or have questions after reviewing this guide, please take advantage of Crestron's award winning customer service team by calling Crestron at 1-888-CRESTRON [1-888-273-7876].

You can also log onto the online help section of the Crestron website (www.crestron.com/onlinehelp) to ask questions about Crestron products. First-time users will need to establish a user account to fully benefit from all available features.

Appendix A: Setting Module Net IDs

The following procedure will normally be performed by an authorized Crestron representative as part of the System Commissioning phase. For system wiring and basic testing as described on pages 7 and 14, it is not necessary to perform this step. Only perform this step if instructed by an authorized Crestron representative, or when replacing modules on a system that have already been commissioned (in the latter case the Net ID should be set to match the Net ID of the module being replaced).

The Net ID of each module in the cabinet can be changed from the front panel of each module. The Net IDs of each module in the system must be unique.

To set the Net ID using the front panel:

1. Press the recessed **SETUP** button to enter the *Setup* mode. The **SETUP** LED illuminates.
2. As shown in the following diagram, press the left button under the **NET ID** display to change the left digit of the Net ID or press the right button under the **NET ID** display to change the right digit of the Net ID number.

Changing the Net ID

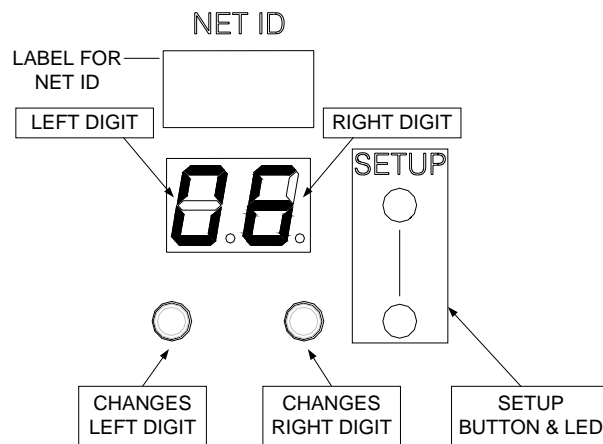

3. When the desired Net ID is displayed, press the **SETUP** button to exit the *Setup* mode. The **SETUP** LED extinguishes.

If the **SETUP** button is not pressed, the *Setup* mode will time out after one minute activity and the Net ID will revert back to its original value.

Appendix B: Specifications

Specifications for the GLXX-HDSW modules are listed in the following table.

GLXX-HDSW Module Specifications

SPECIFICATION	DETAILS
Input Voltage	100 – 347 VAC 50/60 Hz
Supported Load Types	Incandescent, HID, magnetic low voltage (MLV), electronic low voltage (ELV), neon/cold cathode, and fluorescent ballasts, motor
Maximum Load General Use / Electric Discharge Lamp GLR-HD-1P GLR-HD-2P Motor	 20 Amps, 347 Volts AC 20 Amps, 480 Volts AC 0.5 HP at 110-125 Volts AC 1.5 HP at 220-277 Volts AC
Environmental Temperature Humidity Heat Dissipation	 32° to 104° F (0° to 40° C) 10% to 90% RH (non-condensing) 10 BTU/Hr
Cresnet Power Usage	5W (Entire Cabinet)

Appendix C: Network Wiring

Check Network Wiring

Use the Right Wire

In order to ensure optimum performance over the full range of your installation topology, Crestron Certified Wire and only Crestron Certified Wire may be used. Failure to do so may incur additional charges if support is required to identify performance deficiencies because of using improper wire.

Calculate Power

CAUTION: Use only Crestron power supplies for Crestron equipment. Failure to do so could cause equipment damage or void the Crestron warranty.

CAUTION: Provide sufficient power to the system. Insufficient power can lead to unpredictable results or damage to the equipment. Please use the Crestron Power Calculator to help calculate how much power is needed for the system (www.crestron.com/calculators).

When calculating the length of wire for a particular Cresnet run, the wire gauge and the Cresnet power usage of each network unit to be connected must be taken into consideration. Use Crestron Certified Wire only. If Cresnet units are to be daisy-chained on the run, the Cresnet power usage of each network unit to be daisy-chained must be added together to determine the Cresnet power usage of the entire chain. If the unit is home-run from a Crestron system power supply network port, the Cresnet power usage of that unit is the Cresnet power usage of the entire run. The wire gauge and the Cresnet power usage of the run should be used in the following equation to calculate the cable length value on the equation's left side.

Cable Length Equation

$$L < \frac{40,000}{R \times P}$$

Where: L = Length of run (or chain) in feet
 R = 6 Ohms (Crestron Certified Wire: 18 AWG (0.75 MM²))
 or 1.6 Ohms (Cresnet HP: 12 AWG (4 MM²))
 P = Cresnet power usage of entire run (or chain)

Make sure the cable length value is less than the value calculated on the right side of the equation. For example, a Cresnet run using 18 AWG Crestron Certified Wire and drawing 20 watts should not have a length of run more than 333 feet (101 meters). If Cresnet HP is used for the same run, its length could extend to 1250 feet (381 meters).

NOTE: All Crestron certified Cresnet wiring must consist of two twisted pairs. One twisted pair is the +24V conductor and the GND conductor and the other twisted pair is the Y conductor and the Z conductor.

Strip and Tin Wire

When daisy-chaining Cresnet units, strip the ends of the wires carefully to avoid nicking the conductors. Twist together the ends of the wires that share a pin on the network connector and tin the twisted connection. Apply solder only to the ends of the twisted wires. Avoid tinning too far up the wires or the end becomes brittle. Insert the tinned connection into the Cresnet connector and tighten the retaining screw. Repeat the procedure for the other three conductors.

Add Hubs

Use of a Cresnet Hub/Repeater (CNXHUB) is advised whenever the number of Cresnet devices on a network exceeds 20 or when the combined total length of Cresnet cable exceeds 3000 feet (914 meters).

Crestron Network Interconnect Diagram

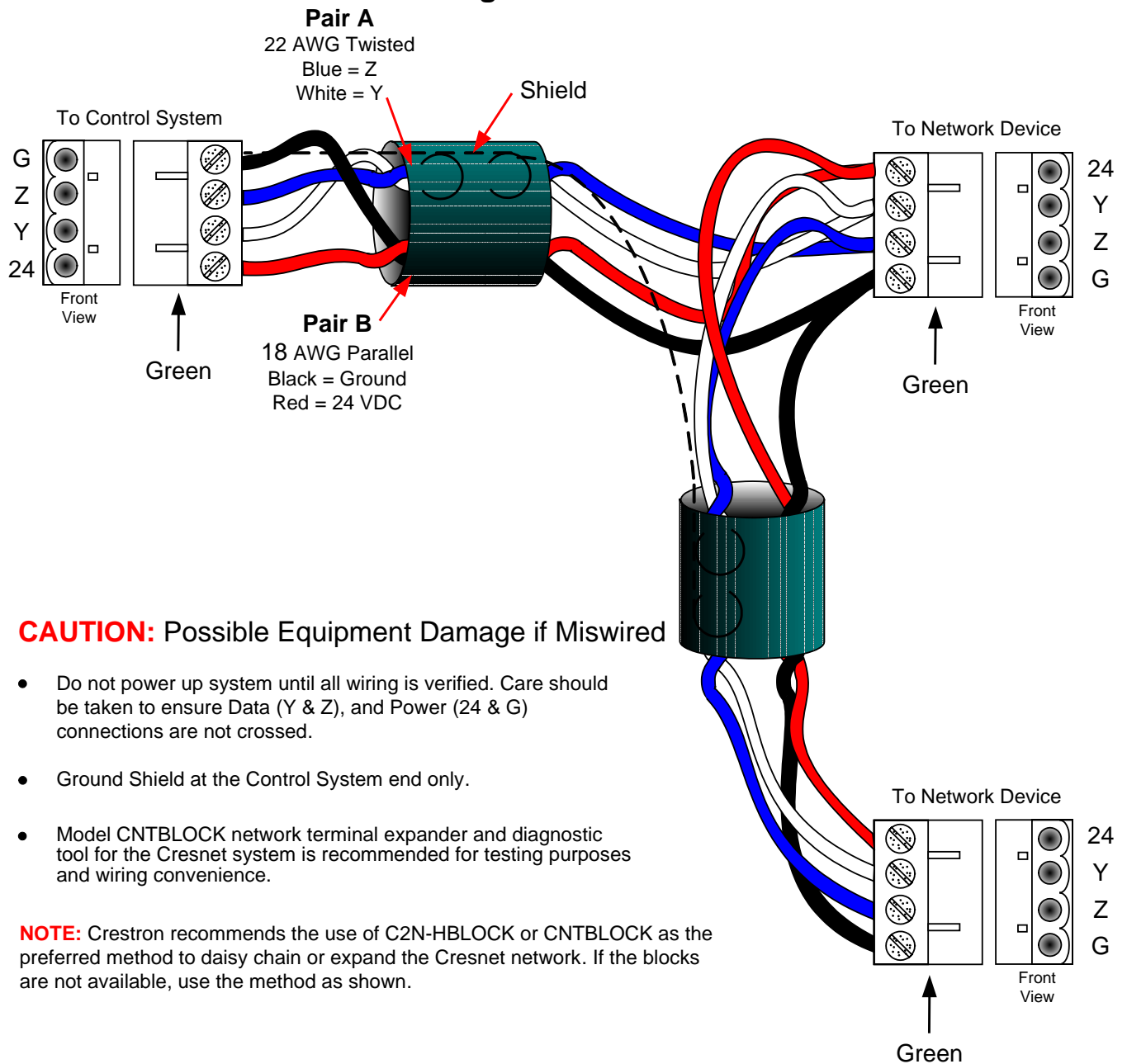

CAUTION: Possible Equipment Damage if Miswired

- Do not power up system until all wiring is verified. Care should be taken to ensure Data (Y & Z), and Power (24 & G) connections are not crossed.
- Ground Shield at the Control System end only.
- Model CNTBLOCK network terminal expander and diagnostic tool for the Cresnet system is recommended for testing purposes and wiring convenience.

NOTE: Crestron recommends the use of C2N-HBLOCK or CNTBLOCK as the preferred method to daisy chain or expand the Cresnet network. If the blocks are not available, use the method as shown.

Crestron Network to Mini Network Interconnect Diagram

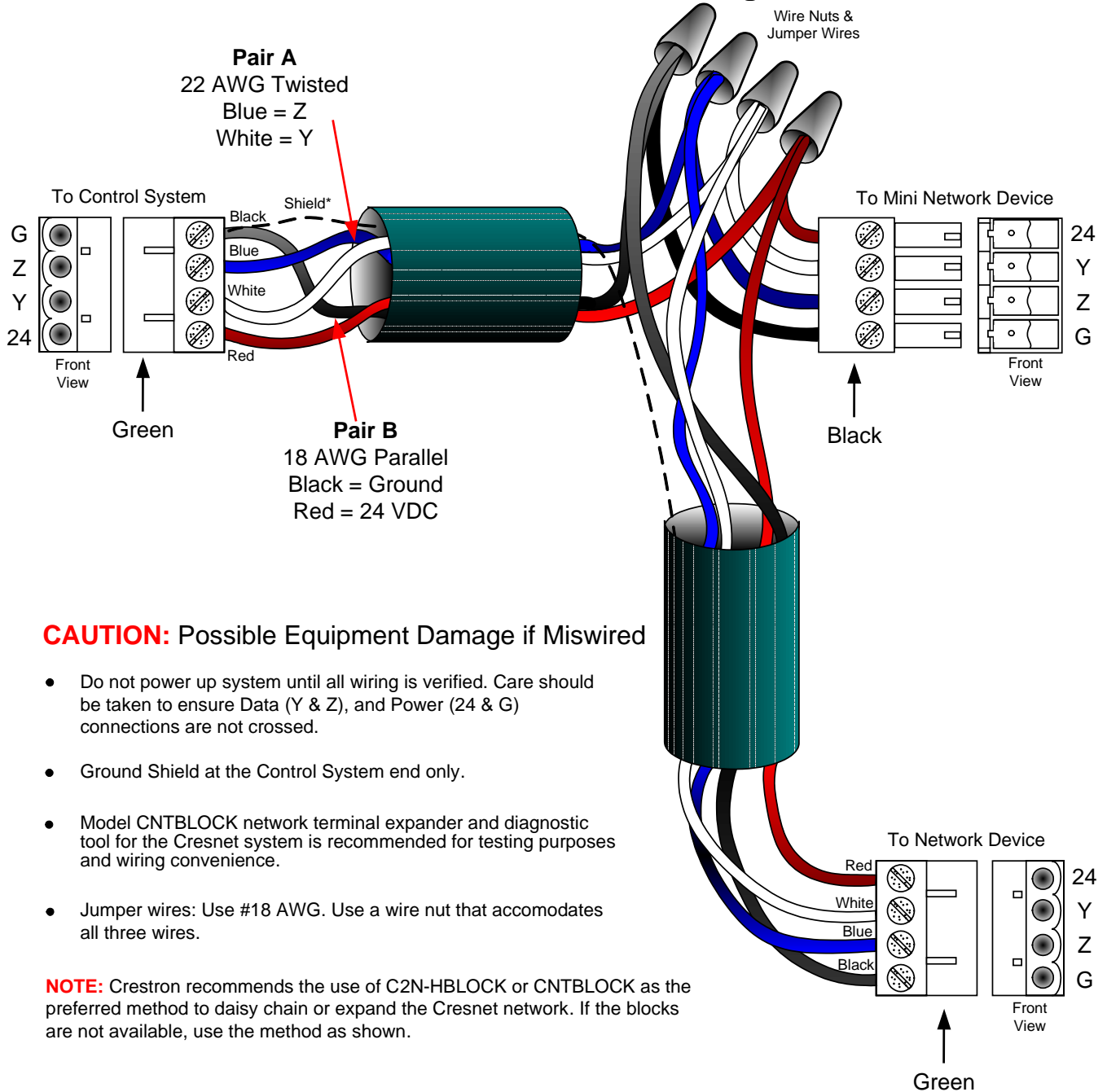

This page is intentionally left blank.

Return and Warranty Policies

Merchandise Returns / Repair Service

1. No merchandise may be returned for credit, exchange or service without prior authorization from CRESTRON. To obtain warranty service for CRESTRON products, contact an authorized CRESTRON dealer. Only authorized CRESTRON dealers may contact the factory and request an RMA (Return Merchandise Authorization) number. Enclose a note specifying the nature of the problem, name and phone number of contact person, RMA number and return address.
2. Products may be returned for credit, exchange or service with a CRESTRON Return Merchandise Authorization (RMA) number. Authorized returns must be shipped freight prepaid to CRESTRON, 6 Volvo Drive, Rockleigh, N.J. or its authorized subsidiaries, with RMA number clearly marked on the outside of all cartons. Shipments arriving freight collect or without an RMA number shall be subject to refusal. CRESTRON reserves the right in its sole and absolute discretion to charge a 15% restocking fee plus shipping costs on any products returned with an RMA.
3. Return freight charges following repair of items under warranty shall be paid by CRESTRON, shipping by standard ground carrier. In the event repairs are found to be non-warranty, return freight costs shall be paid by the purchaser.

CRESTRON Limited Warranty

CRESTRON ELECTRONICS, Inc. warrants its products to be free from manufacturing defects in materials and workmanship under normal use for a period of three (3) years from the date of purchase from CRESTRON, with the following exceptions: disk drives and any other moving or rotating mechanical parts, pan/tilt heads and power supplies are covered for a period of one (1) year; touchscreen display and overlay components are covered for 90 days; batteries and incandescent lamps are not covered.

This warranty extends to products purchased directly from CRESTRON or an authorized CRESTRON dealer. Purchasers should inquire of the dealer regarding the nature and extent of the dealer's warranty, if any.

CRESTRON shall not be liable to honor the terms of this warranty if the product has been used in any application other than that for which it was intended or if it has been subjected to misuse, accidental damage, modification or improper installation procedures. Furthermore, this warranty does not cover any product that has had the serial number altered, defaced or removed.

This warranty shall be the sole and exclusive remedy to the original purchaser. In no event shall CRESTRON be liable for incidental or consequential damages of any kind (property or economic damages inclusive) arising from the sale or use of this equipment. CRESTRON is not liable for any claim made by a third party or made by the purchaser for a third party.

CRESTRON shall, at its option, repair or replace any product found defective, without charge for parts or labor. Repaired or replaced equipment and parts supplied under this warranty shall be covered only by the unexpired portion of the warranty.

Except as expressly set forth in this warranty, CRESTRON makes no other warranties, expressed or implied, nor authorizes any other party to offer any warranty, including any implied warranties of merchantability or fitness for a particular purpose. Any implied warranties that may be imposed by law are limited to the terms of this limited warranty. This warranty statement supersedes all previous warranties.

Trademark Information

All brand names, product names and trademarks are the sole property of their respective owners. Windows is a registered trademark of Microsoft Corporation. Windows95/98/Me/XP/Vista/7 and WindowsNT/2000 are trademarks of Microsoft Corporation.