

### 1 A. Check Contents



Depending on the configuration you ordered, you should have received:

AMS, AMS-XM, or AMSI Adagio Media System

One or more Dual Radio Tuner(s)  
 ATC-AMFM2 Tuner  
 ATC-AMFMXM Tuner  
 ATC-AMFMSR Tuner

Antenna(s) supplied with tuner(s)  
 AM FM XM<sup>®</sup> Sirius<sup>®</sup>



AMS Operation Guide  
 AMS QuickStart Guide (this guide)  
 Operation Guide(s) for:  
 ATC-AMFM2 Tuner  
 ATC-AMFMXM Tuner  
 ATC-AMFMSR Tuner

Keypads and/or Controllers  
 C2N-DBF12  
 APAD

Optional Devices  
 CEN-IDOC Interface for Apple<sup>®</sup> iPod<sup>®</sup> CEN-IDOC)  
 Adagio Audio Server (AAS)  
 Adagio Audio Expander (AAE)

Parts bag(s) containing connecting hardware, cables, and adapters

**NOTE:** This system has specific out-of-the-box functionality that is outlined in this guide. No programming is required to get started!

### B. Equipment/Tools Required

The following items are not supplied and are needed to complete the installation:

- CAT5/5E cables\* for Ethernet connections (Step 3A)
- RCA cables for connection of audio sources (Steps 3C & 5 E and F)
- Cables for video sources (Step 2)
- Cresnet<sup>®</sup> cable\* for network connection of Crestron devices throughout the home (Steps 4 and 5)
- Speaker wire (12 AWG max.) for connection of speakers throughout the home. (Steps 2, 4A - C, & 5A and B)
- Speaker wire (10 AWG max.) for connection of speakers in the home theater. (Step 2)
- DHCP-enabled Ethernet router (Step 3A)
- Grounding wire (16 AWG) For grounding audio equipment together and connection to earth ground.
- Appropriate hand tools (wire cutters, screwdrivers, etc.)

- Wire lugs to attach the ground wires to the equipment.
- \* In order to ensure optimum performance over the full range of your installation topology, Crestron Certified Wire, and only Crestron Certified Wire, may be used for Cresnet and CAT5 connections. Failure to do so may incur additional charges if support is required to identify performance deficiencies because of using improper wire.

### C. Before Starting

- CAUTION:** Do not connect power cords until instructed to do so.
- CAUTION:** Do not run speaker wire parallel to electrical wiring or Cresnet wiring.
- CAUTION:** Do not bridge amplifier outputs.

**NOTE:** Before beginning any of these QuickStart procedures, make certain that all speaker wires and Cresnet cables are installed throughout the home.

### 2 Connections for Theater Configurations

Speaker level wiring is shown. Use pre-amp connections if desired to connect to external amplifiers. The sub woofer can be connected to the RCA connector or the 3-position terminal block connector as desired.

- Use 12 AWG max. cables to the room speakers; use 10 AWG max. cables to the theater speakers.
- Connect theater AV sources and display to the appropriate connectors.
- Control of the display is accomplished using software tools. Refer to the AMS Operations Guide for details.

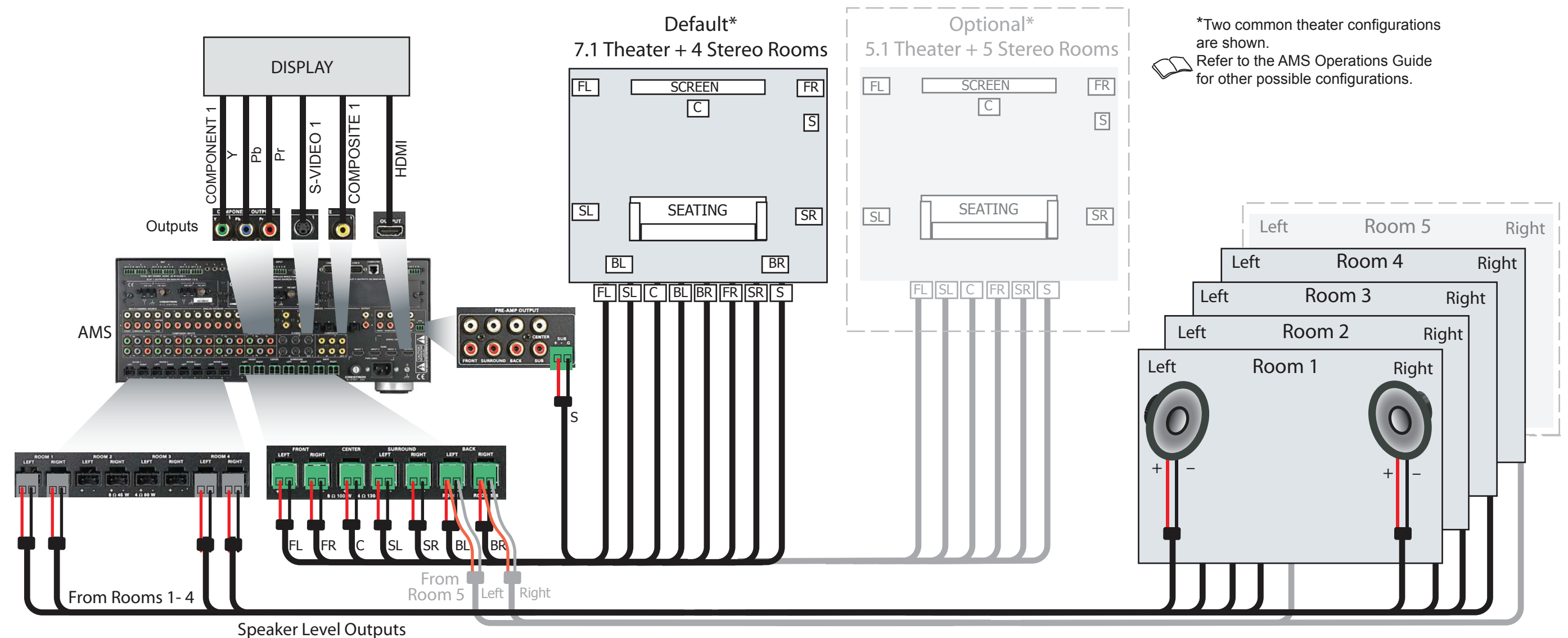



### 3 Connect Optional Network and Audio Sources

- Connect the optional Adagio Audio Server (AAS) and CEN-IDOC to the AMS through a third party DHCP-enabled Ethernet router using CAT5/5E cables (not supplied).
- Connect the docking station (CEN-IDOC-DS) supplied with the optional CEN-IDOC to the port on the rear of the CEN-IDOC using the supplied cable.
- Connect the audio outputs of the CEN-IDOC and AAS to available AMS SOURCES connectors using RCA cables:
  - Connect the CEN-IDOC outputs to source 5.
  - Connect the AAS outputs to sources 7 - 10.

**NOTE:** If the configuration includes an AAE, connect CEN-IDOC and AAS audio outputs to the AAE loop through SOURCES connectors, not to the AMS. Refer to Step 5.

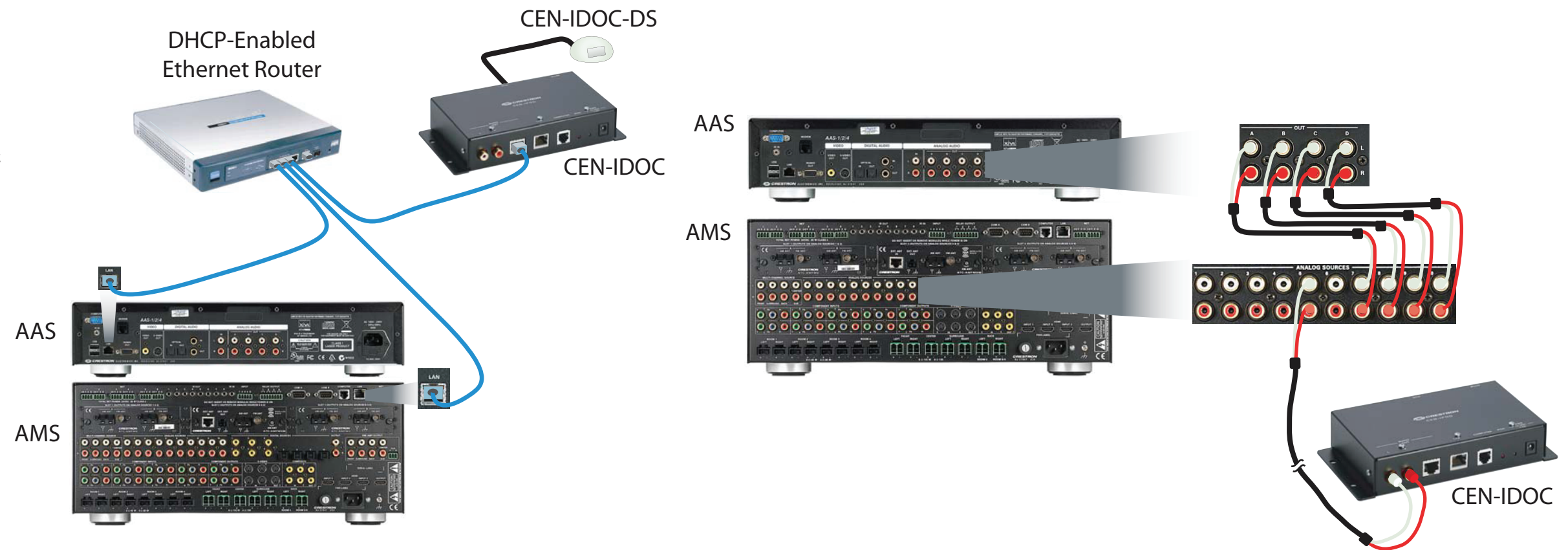

### 4 Connect Keypads, Controllers, and Speakers

- Connect the previously installed 16 AWG minimum (up to 12 AWG) speaker wire to the speakers in rooms 1 - 6. Observe the polarity of the wires to each speaker (black = -, red = +).
- NOTE:** Use speakers that are rated for full available output. Do not connect more than two 8-Ohm speakers in parallel or one 4-Ohm speaker to each output.
- Connect the speaker wire from rooms 1 - 4 to the AMS ROOMS connectors using the 2-pin socket connectors provided.
  - Connect the speaker wire from rooms 5 or 6 to the AMS BACK connectors using the 2-pin socket connectors provided.\*
  - Connect the keypads (C2N-DBF12) and/or controllers (APAD) in rooms 1 - 6 to previously installed Cresnet cables.
  - Connect the Cresnet cables from the rooms to the appropriate NET connectors on the AMS (e.g., Room 1 to Net 1, etc.). Typical wiring connections are shown below.

\*Connection to rooms 5 and 6 depend on the configuration selected. For detailed information, refer to the AMS Operations Guide.

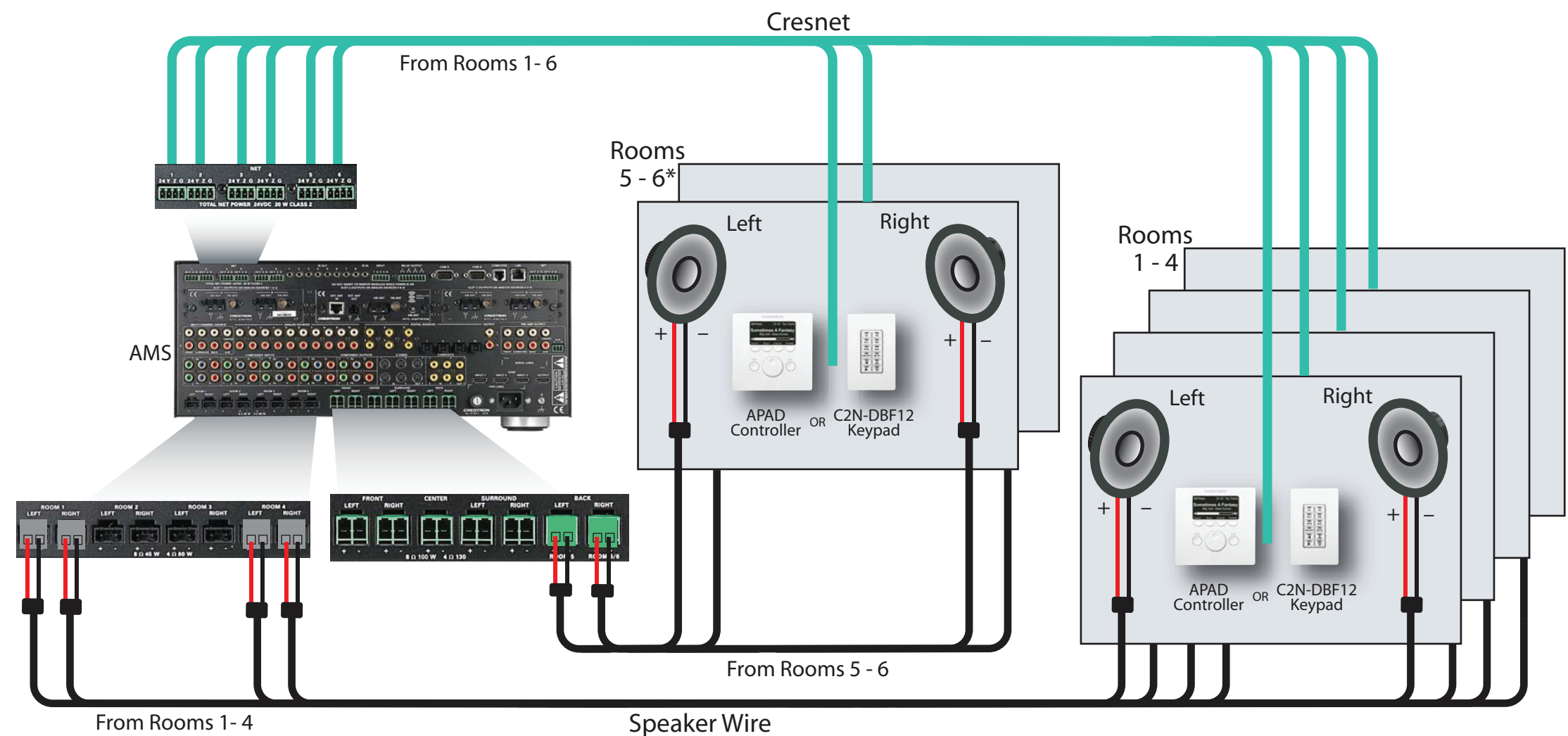
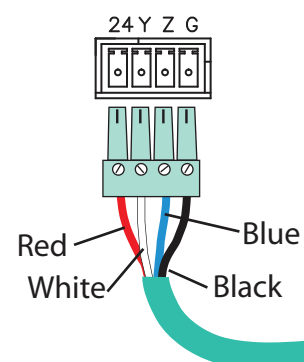



### 5 Connect the Optional Adagio Audio Expander (AAE)

The following steps can be performed in any convenient order. Steps A through D are performed in the same way that similar connections were made to the AMS (Step 4), and are not illustrated again here.

- A. Connect previously installed 16 AWG minimum (up to 12 AWG) speaker wire to the speakers in rooms 7 - 12. Observe the polarity of the wires to each speaker.

**NOTE:** Use speakers that are rated for full available output. Do not connect more than two 8-Ohm speakers in parallel to each output.

- B. Connect the speaker wire from rooms 7 - 12 to the AAE ROOMS connectors (Rooms 1 - 6) using the 2-pin socket connectors provided.
- C. Connect the keypads (C2N-DBF12) or controllers (APAD) in rooms 7 - 12 to previously installed Cresnet cables.

- D. Connect the Cresnet cables from rooms 7 - 12 to the appropriate NET connectors 1 - 6 on the AAE (e.g., Room 7 to NET 1, etc.).

- E. Connect the AMS NET and AAE NET LOOP THRU inputs using standard Cresnet cable.

- F. Connect the AMS theater downmix from the AMS OUTPUT connectors to the appropriate available AAE SOURCES connector (default is 6).

**NOTE:** Specific connection to the AAE SOURCES connectors depends on the number and type of optional audio sources used in the system. Refer to Step 3 and to the AMS Operations Guide for details.

- G. Analog sources connect to the AAE SOURCES connectors; the sources are then shared with the AMS ANALOG SOURCES connectors through the AAE loop through inputs. The wiring method shown here is standard practice, but connections can be made to either side of the AAE connector set.

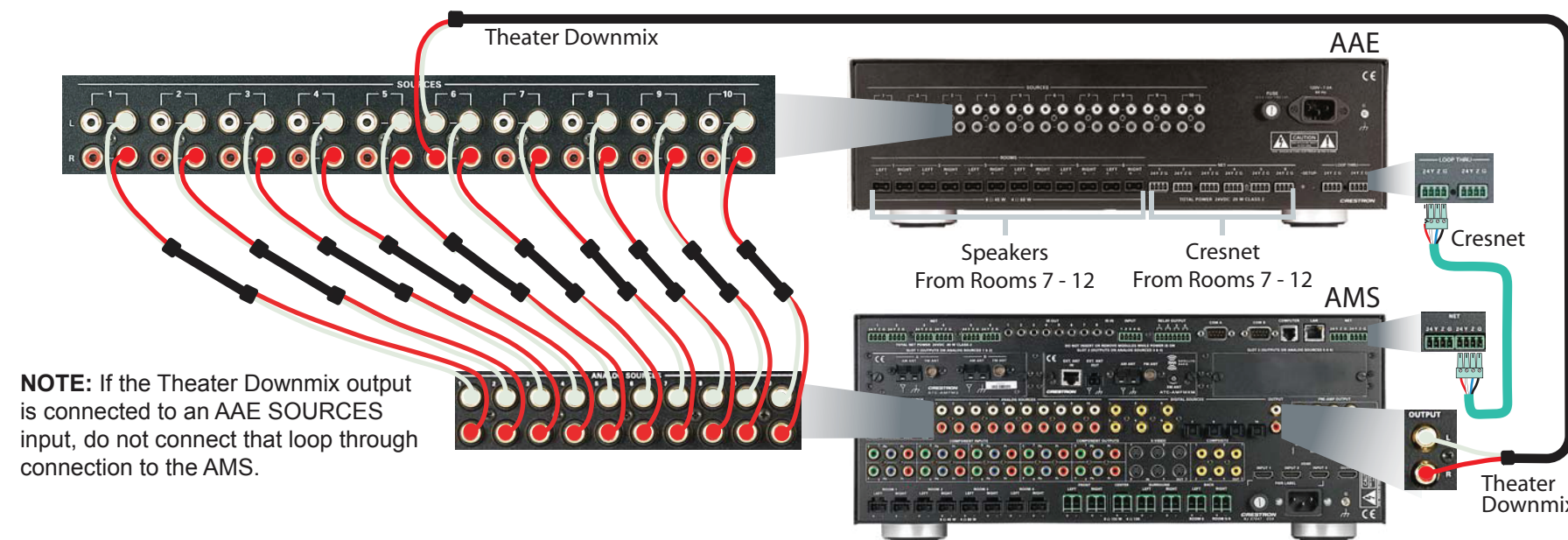

### 7 Connect Grounds

Using 16 AWG wire with ground lugs (not supplied), connect the ground terminals on the rear of the AMS and the optional AAE to a case screw on the rear of the optional AAS, and to an earth ground. Chassis grounds from external audio sources should also be connected to the AMS ground screw.

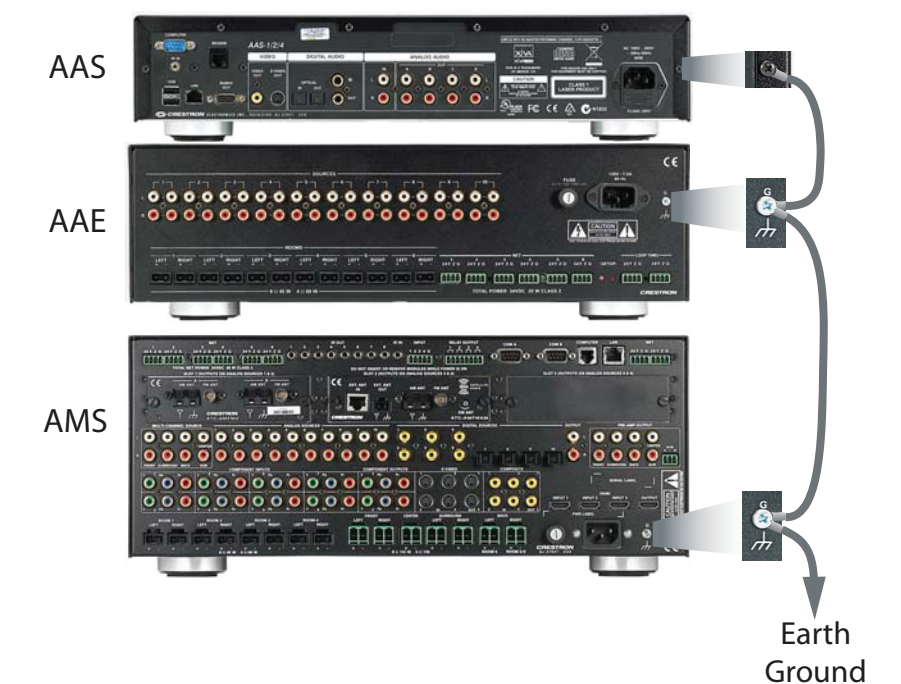

### 6 Install Dual Tuner Cards

**CAUTION:** Tuner cards are electrostatic-sensitive devices. Wear a grounding strap or touch the metal chassis of a known grounded device before handling and installing cards.

**CAUTION:** Do not connect external sources to SOURCES connectors used by installed tuner cards.

**NOTE:** Make sure that the power cord is not connected before installing any tuner cards.

- A. Remove screws securing the plate covering the card slot to be used. Insert the tuner card into the slot side rails, and make certain card is fully seated before using the attached screws to secure it in position.
- B. Install tuner cards in Slots 1 and 2 only, for out-of-the-box functionality. (One card may already be installed in Slot 1.) Either card may be installed in either slot.

**NOTE:** The output of each dual tuner card occupies two of the ten available source connections in the AMS. Slot 1 outputs are on SOURCES 1 and 2, Slot 2 outputs are on SOURCES 3 and 4. After installing the tuner card(s), the remaining connections may be used for other audio sources.

- C. Connect the antennas included with the tuner cards. Refer to the guide included with the tuner(s) for details on connection and antenna placement.

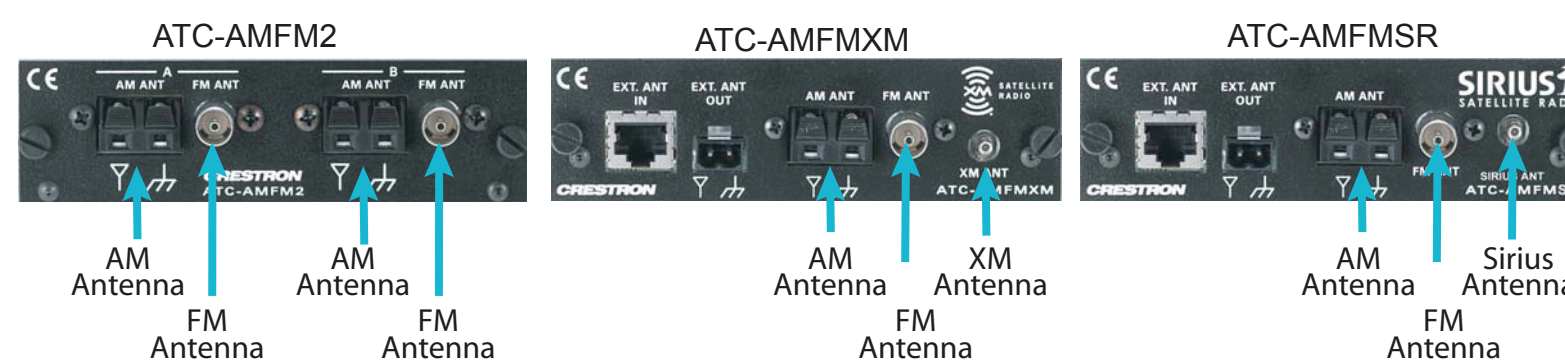
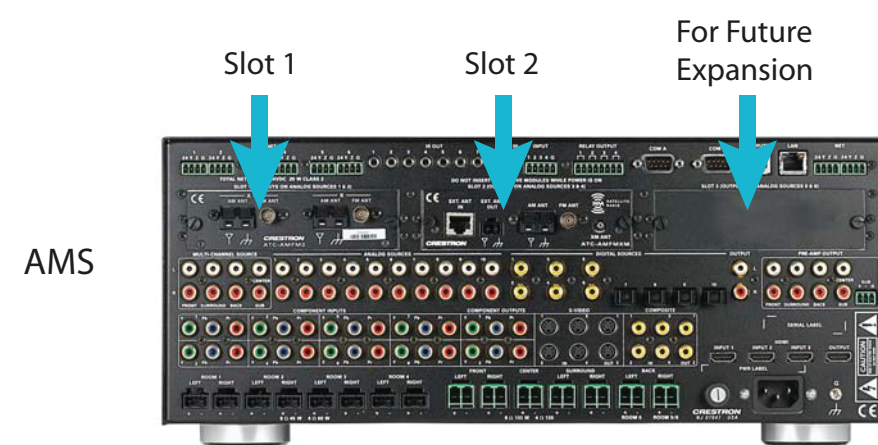

### 8 Apply Power

**CAUTION:** If you are adding Crestron equipment beyond the devices mentioned in this guide, be aware that insufficient power can lead to unpredictable results or damage to the equipment. Please use the Crestron Power Calculator, available from the Crestron website (<http://www.crestron.com>), to help calculate how much power is needed for the system.

**NOTE:** The AMS, AAS, and AAE units do not have a power switch. Power is applied to the units by plugging in their respective power cords.

- A. Connect the AC power cord to the AMS and, if applicable, to the optional AAS and AAE. Then connect the power cord(s) to AC power.
- B. Connect power to all other system devices as required. (Cresnet supplies power to the APAD controller and the C2N-DBF12 keypads.)



### 9 Installer Tools Mode

- A. Verify that power to the AMS is on. After a few seconds, **Loading . . .** appears on the display. The unit then goes through an internal startup procedure that takes about one minute.
- B. When the display shows a tuner source, press and hold the **SOURCE** and **ROOM** buttons at the same time for about 10 seconds to enter the **Installer Tools** mode. This mode provides a series of menus and sub-menus, shown to the right, that let you perform a first time setup and basic configuration options.
1. Perform the functions in the order listed in the menu.
  2. Use the **Selection Knob** to underscore each function and press the **Enter** button to select it.
  3. Follow the on-screen instructions for each function.
  4. Press the **Enter** button to select an on-screen choice.
  5. Use soft buttons to select choices at the bottom of a menu screen.
  6. The **MENU** button always takes you back to the Installer Tools menu.
  7. When all **Installer Tools** mode functions are completed, use the **MENU** button to exit to Source mode.

Advanced setup information and operational details are given in the AMS Operations Guide.

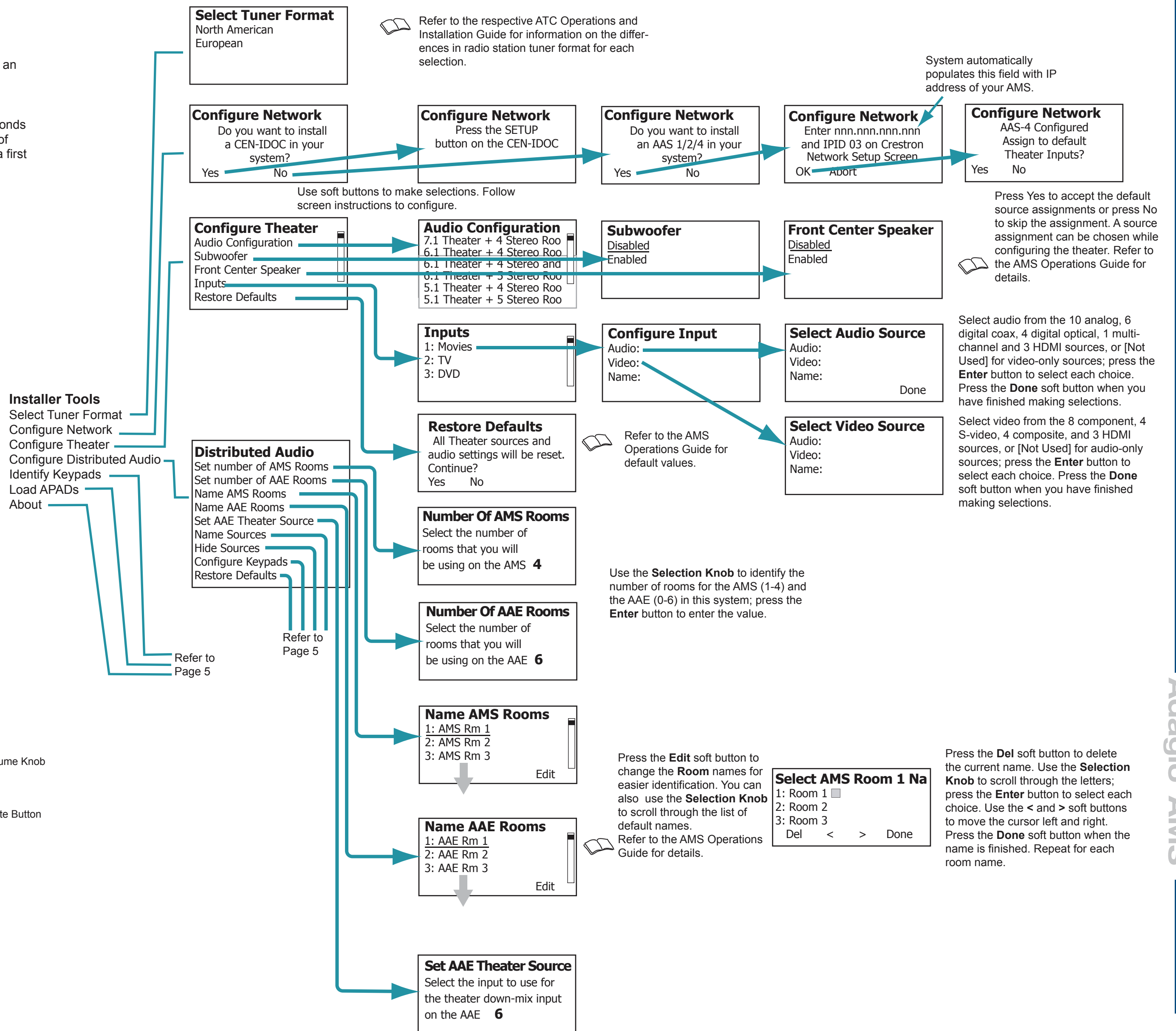
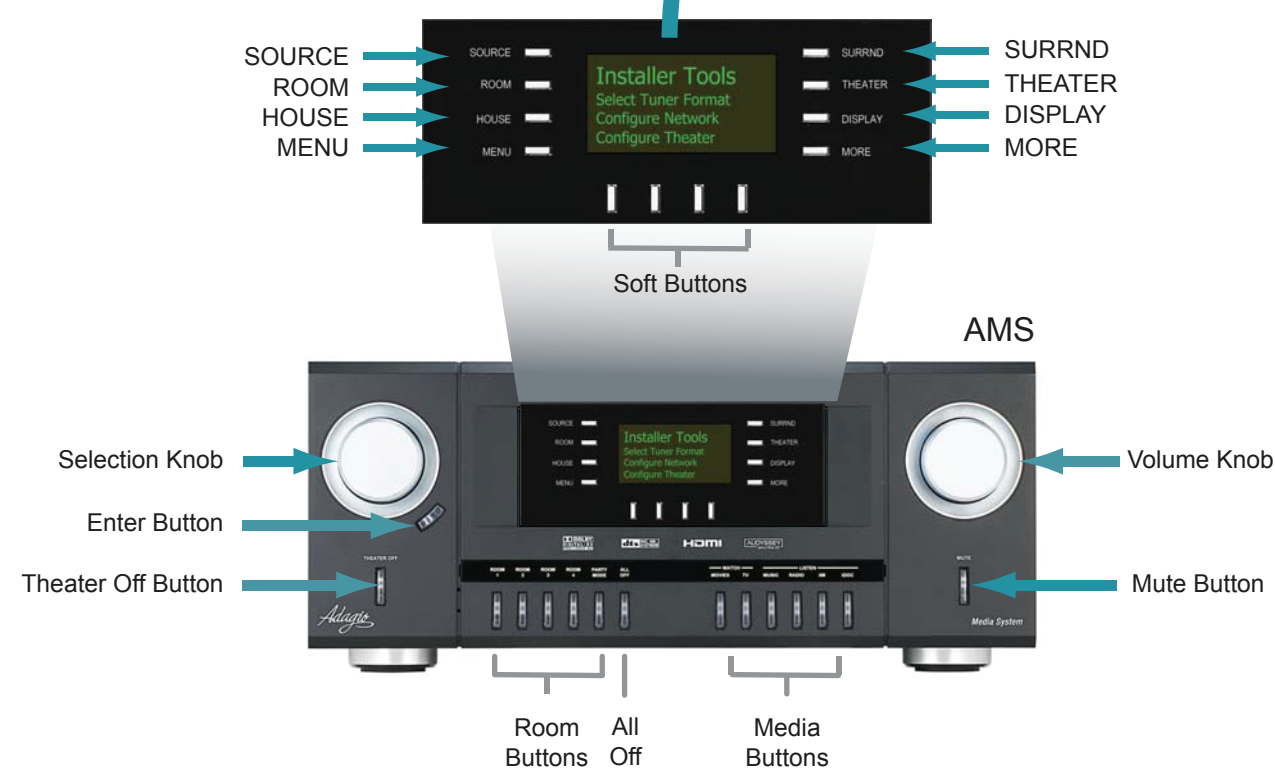



### 9 Installer Tools Mode (Continued)

Refer to Page 4

- Distributed Audio
- Set number of AMS Rooms
- Set number of AAE Rooms
- Name AMS Rooms
- Name AAE Rooms
- Set AAE Theater Source
- Name Sources
- Hide Sources
- Configure Keypads
- Restore Defaults

**Select Source to Name**

1: Source 1  
2: Source 2  
3: Source 3

Edit

Press **Enter** or the **Edit** soft button to change source names for easier identification.

**Select Source to Name**

1: [Custom Name]  
2: Source 2  
3: Source 3

Edit

Use the **Selection Knob** to choose [Custom Name] or one of several preset names. Press **Enter** to accept the choice. If a preset name is selected, that name appears for the source. If [Custom Name] is chosen, press the **Edit** soft button to enable entering a preferred name for the source.

**Enter Source 1 Name**

1: [Custom Name]  
2: Source 2  
3: Source 3

Del < > Done

Press the **Del** soft button to delete the current name. Use the **Selection Knob** to scroll through the letters; press the **Enter** button to select each choice. Use the < and > soft buttons to move the cursor left and right. Press the **Done** soft button when the name is finished. Repeat for each source name. Refer to the AMS Operations Guide for details.

**Hide Sources**

1: Source 1  
2: Source 2  
3: Source 3

Hide Show

Use the **Hide** and **Show** soft buttons to hide or show the names of each source (up to 10 plus the Theater Source) connected to the system. Refer to the AMS Operations Guide for details.

**Select Button to Map**

Btn1: Source 1  
Btn2: Source 2  
Btn3: Source 3

Edit

**Select Src. for Button 2**

Btn1: Source 1  
Btn2: [CEN-IDOC]  
Btn3: AM/FM Tuner

Done

Use the **Selection Knob** to select the C2N-DBF12 button to map. Press the **Edit** soft button, and use the **Selection Knob** to select the source. Refer to the diagram on the right for the position of buttons 1 - 6. Use the supplied button caps to label the buttons to match the source selections. Refer to the Operations manual for the C2N-DBF12 as necessary to install the button caps.

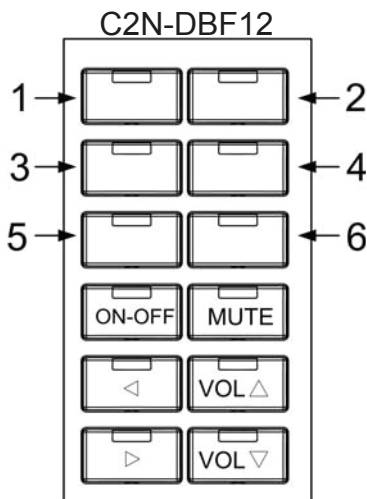

Default functionality of any C2N-DBF12 connected to the AMS.

**Restore Defaults**

All Audio Distribution source and audio settings will be reset. Continue?

Yes No

Refer to the AMS Operations Guide for default values.

- Identify Keypads
- Load APADs
- About

**Identify Keypads**

Warning: All keypads will need to be re-identified. Continue?

Yes No

**Warning:**

All room APADs will be loaded with default functionality. Continue?

Yes No

**Identify Keypads**

Select keypad type for Theater

APAD None

**Identify Keypads**

Press any key on the APAD in Theater

APAD 12 But None

**Identify Keypads**

Select keypad type for Room 1

APAD 12 But None

**Identify Keypads**

Press any button on the keypad in Room 1

Refer to the AMS Operations Guide for default values.

The specific patents that cover Crestron products are listed at [patents.crestron.com](http://patents.crestron.com).

Crestron, the Crestron logo, Adagio, and Cresnet are either trademarks or registered trademarks of Crestron Electronics, Inc. in the United States and/or other countries. Apple and iPod are either trademarks or registered trademarks of Apple, Inc. in the United States and/or other countries. SIRIUS, the SIRIUS logo, XM, and the XM logo are either trademarks or registered trademarks of SIRIUS XM Radio Inc. in the United States and/or other countries. Other trademarks, registered trademarks, and trade names may be used in this document to refer to either the entities claiming the marks and names or their products. Crestron disclaims any proprietary interest in the marks and names of others. *Crestron is not responsible for errors in typography or photography.*

This document was written by the Technical Publications department at Crestron. ©2013 Crestron Electronics, Inc.

### 10 Verify Operation

After the **Installer Tools** mode functions are finished, press a **ROOM** button, then press the **Source** soft button and use the **Selection Knob** to select available audio and video sources. Adjust the **Volume Knob** as necessary; press the **MORE** button to adjust the tone controls, and verify basic operation of your Adagio Media System.

To verify the Theater operation, press the **THEATER** button. Press **Source** and use the **Selection Knob** to choose different sources. Press the **Bklt** soft button to adjust the display illumination; press the **Off** soft button to turn off the theater zone audio (the button legend changes to **On**). Press the button again to turn the audio back on. Adjust the **Volume Knob** as necessary; press the **MORE** button to adjust the tone controls.

Theater

TV

Dolby Digital 5.1

Source Bklt Off

### 11 Room and Source Setup

Press the **ROOM** button and select a room. Press the **ROOM** and **MORE** buttons simultaneously for about three seconds. Then, follow the screen instruction and use the soft buttons to select each parameter to be adjusted. The screen shows a gauge for the selected parameter at its current value. Use the **Selection Knob** to adjust the value as desired. Press the **MENU** button to choose a different parameter. Repeat for each room.

**Room 1**

Select Parameter to Adjust

MinV MaxV StartV Mono

Room 1

Min Volume 5%

Reset

For theater setup, press the **THEATER** button and then press the **THEATER** and **MORE** buttons simultaneously for about three seconds. The screen shows three parameters that you can adjust to set the minimum, maximum, and starting volume for the theater. Use the soft buttons to select the parameter, and use the **Selection Knob** to adjust the level.

Theater

Select Parameter to Adjust

Min V Max V Start V

Press the **SOURCE** button and select a source. Then press the **SOURCE** and **MORE** buttons simultaneously for about three seconds. The screen shows a gauge for the current gain setting of the selected source. Use the **Selection Knob** to adjust the gain as desired. (Use the **Reset** soft button to reset the gain to 0dB.) Repeat for each source.

Refer to the AMS Operations Guide for more details on operation of the system.

**Source 1**

88.00 FM

Mono

Control

Source 1

Gain 0dB

Reset