

Crestron **TPMC-V15-WALL,**  
**V15-WALL & WMKC-V15**  
Wall Mount & Chassis Wall Mount  
Kits for TPMC-V15 & V15

---

Installation Guide



This document was prepared and written by the Technical Documentation department at:



Crestron Electronics, Inc.  
15 Volvo Drive  
Rockleigh, NJ 07647  
1-888-CRESTRON

## Regulatory Compliance

As of the date of manufacture, the TPMC-V15-WALL, V15-WALL and WMKC-V15 have been tested and found to comply with specifications for CE marking and standards per EMC and Radiocommunications Compliance Labelling.



---

### Federal Communications Commission (FCC) Compliance Statement

This device complies with part 15 of the FCC Rules. Operation is subject to the following conditions: (1) This device may not cause harmful interference and (2) this device must accept any interference received, including interference that may cause undesired operation.

**CAUTION:** Changes or modifications not expressly approved by the manufacturer responsible for compliance could void the user's authority to operate the equipment.

**NOTE:** This equipment has been tested and found to comply with the limits for a Class B digital device, pursuant to part 15 of the FCC Rules. These limits are designed to provide reasonable protection against harmful interference in a residential installation. This equipment generates, uses and can radiate radio frequency energy and, if not installed and used in accordance with the instructions, may cause harmful interference to radio communications. However, there is no guarantee that interference will not occur in a particular installation. If this equipment does cause harmful interference to radio or television reception, which can be determined by turning the equipment off and on, the user is encouraged to try to correct the interference by one or more of the following measures:

- Reorient or relocate the receiving antenna
- Increase the separation between the equipment and receiver
- Connect the equipment into an outlet on a circuit different from that to which the receiver is connected
- Consult the dealer or an experienced radio/TV technician for help

---

### Industry Canada (IC) Compliance Statement

This Class B digital apparatus complies with Canadian ICES-003.

Cet appareil numérique de la classe B est conforme à la norme NMB-003 du Canada.

---

# Contents

<b>Wall Mount &amp; Chassis Wall Mount Kits for TPMC-V15 &amp; V15: TPMC-V15-WALL, V15-WALL &amp; WMKC-V15</b>	<b>1</b>
Description.....	1
Setup.....	7
Supplied Hardware.....	7
Installation.....	8
Resources.....	13
Reference Documents.....	13
Further Inquiries.....	13
Future Updates.....	13
Return and Warranty Policies.....	14
Merchandise Returns / Repair Service.....	14
CRESTRON Limited Warranty.....	14



# Wall Mount & Chassis Wall Mount Kits for TPMC-V15 & V15: TPMC-V15-WALL, V15-WALL & WMKC-V15

## Description

Wall Mount and Chassis Wall Mount Kits (TPMC-V15-WALL, V15-WALL and WMKC-V15) for TPMC-V15 and V15 allow wall or flat-surface mounting for the Crestron® TPMC-V15 Integrated 15" Touchpanel and V15 V-Panel™ 15" Touchpanel Display. These kits provide the necessary parts to secure a touchpanel in a mounting surface using one of several mounting options. Refer to the table below for a complete list of mounting options.

### *Mounting Options for TPMC-V15-WALL, V15-WALL and WMKC-V15*

PRE-CONSTRUCTION OPTION	POST-CONSTRUCTION OPTION	MODEL NUMBER	DOCUMENT NUMBER
Back Box Kit	-	BB-V15	6801
Pre-Construction Mount Kit	-	PMK-V15	6802
Mud Mount Kit (Accessory)	-	MMK-V15	6885
-	Mud Mount Kit	WMKM-V15	6885
-	Trim Ring Mount Kit	WMKT-V15	6803

The Installation Guides for the TPMC-V15 and V15 mounting options are available from the Crestron Web site ([www.crestron.com/manuals](http://www.crestron.com/manuals)).

The TPMC-V15-WALL is a pre-assembled TPMC-V15 with chassis wall mount kit (WMKC-V15). This model consists of a TPMC-V15 Integrated 15" Touchpanel mounted inside of a chassis and is ready for mounting in a wall or similar flat surface. Included are six screws to mount the touchpanel and a magnetic bezel. It is available in black or white.

The V15-WALL is a pre-assembled V15 V-Panel with chassis wall mount kit (WMKC-V15). This model consists of a V15 V-Panel 15” Touchpanel Display mounted inside of a chassis and is ready for mounting in a wall or similar flat surface. Included are six screws to mount the touchpanel and a magnetic bezel. It is available in black or white.

The WMKC-V15 provides a solution for converting a TPMC-V15 Integrated 15” Touchpanel or V15 V-Panel 15” Touchpanel Display for mounting in a wall or similar flat surface. Using the WMKC-V15, a TPMC-V15, TPMC-V15-TILT, V15 or V15-TILT model can be effectively converted to the equivalent of a TPMC-V15-WALL or V15-WALL. The kit consists of a VESA mount, metal chassis and a magnetic bezel. It is available in black or white.

The dimensions of the TPMC-V15-WALL, V15-WALL and WMKC-V15 are shown below.

*TPMC-V15-WALL and V15-WALL Overall Dimensions (Front, Side and Rear Views – Without Bezel)*

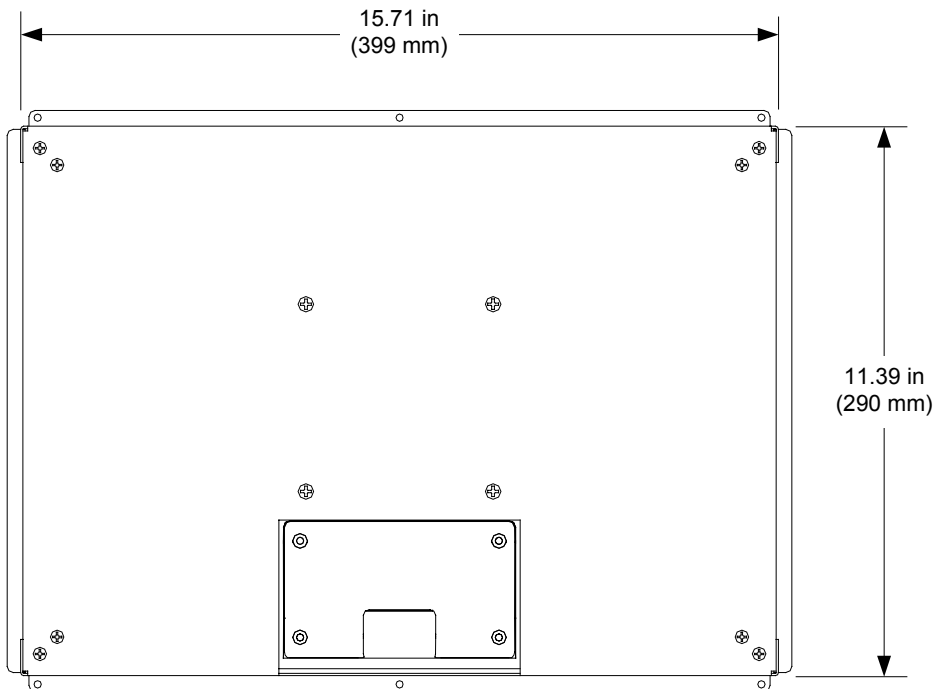
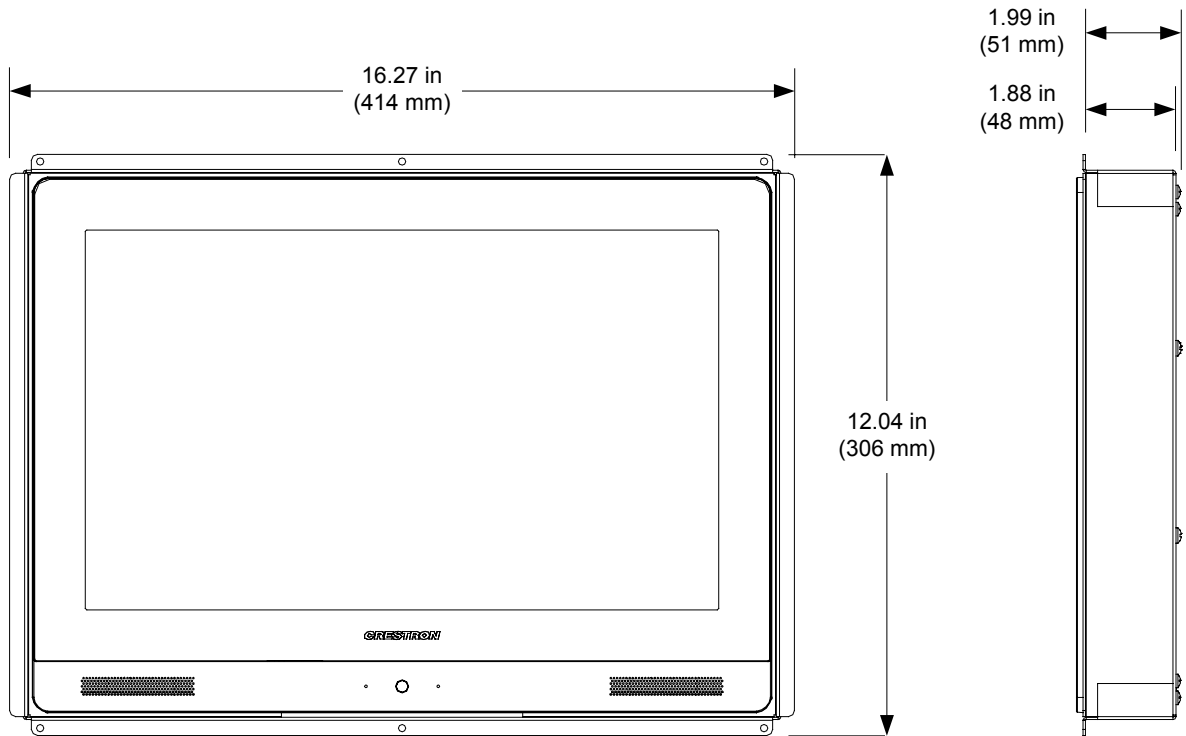

*TPMC-V15-WALL and V15-WALL Overall Dimensions (Front and Side Views - With Bezel)*

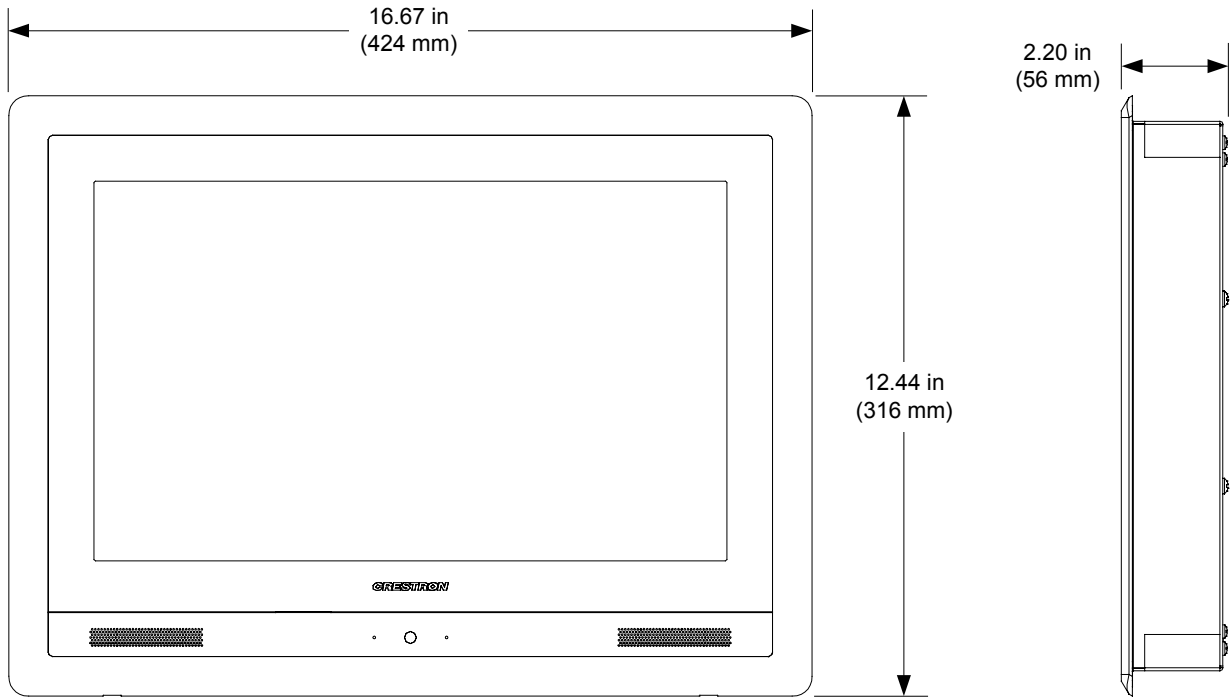



*WMKC-V15 Overall Dimensions (Front, Side and Bottom Views)*

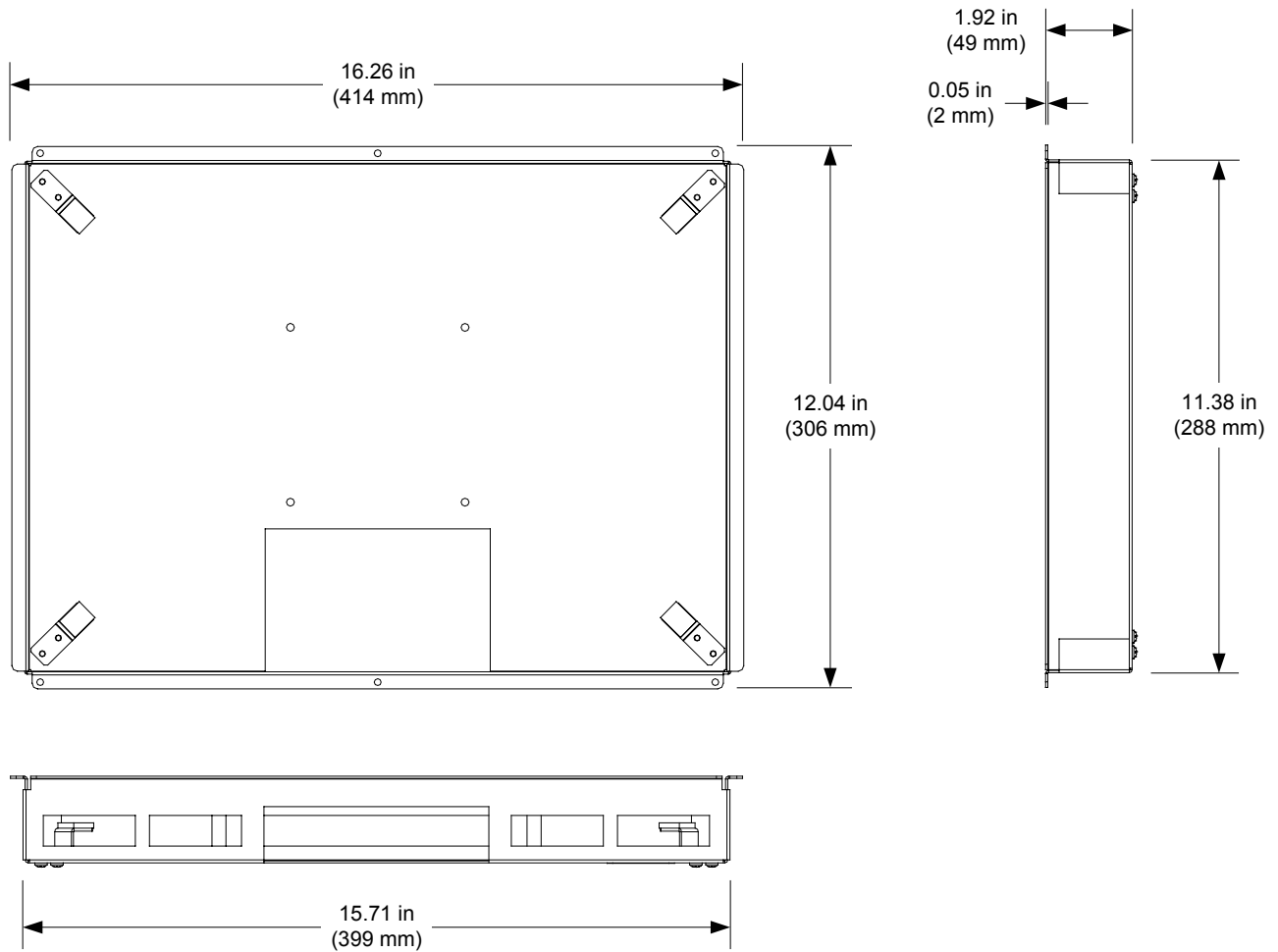

*VESA Mounting Bracket Overall Dimensions (Front and Side Views)*

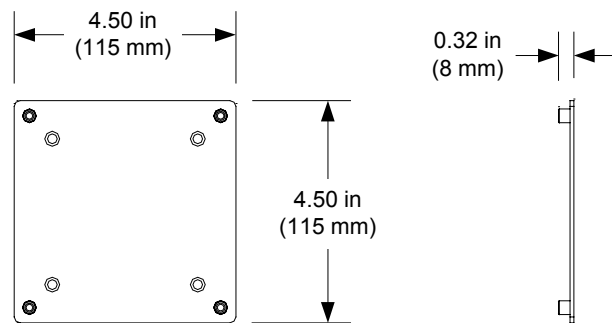

*Bezel Overall Dimensions (Front and Side Views)*

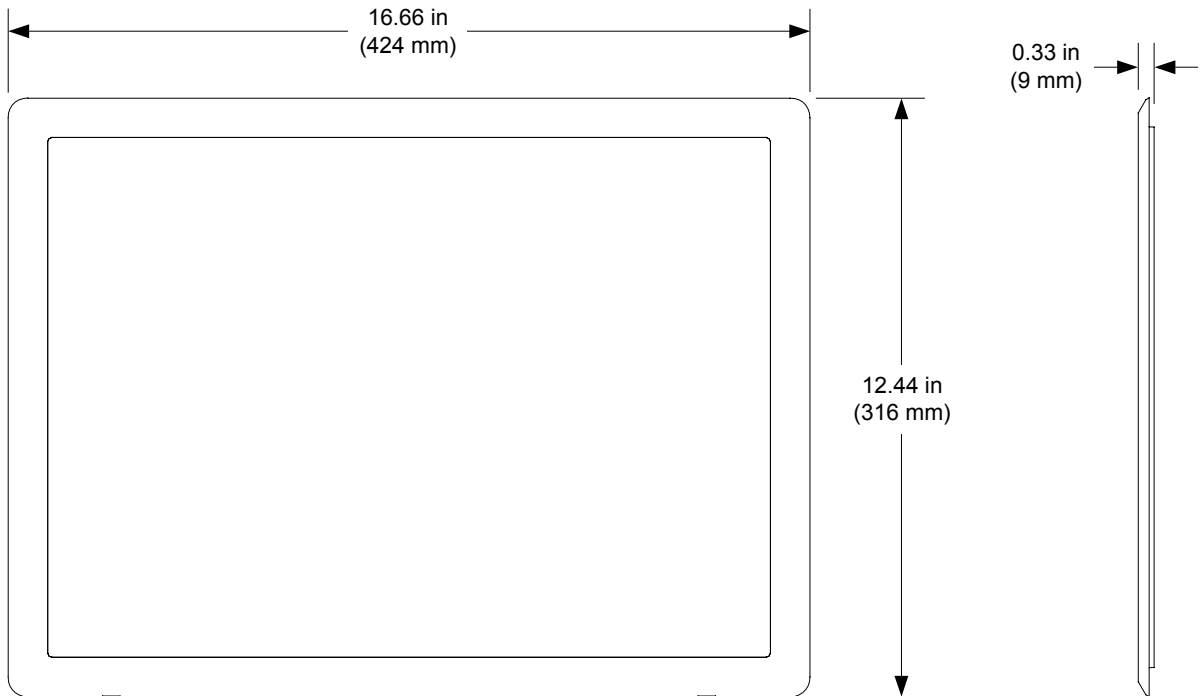

## Setup

### Supplied Hardware

The TPMC-V15-WALL consists of a TPMC-V15 Integrated 15" Touchpanel mounted inside of a chassis. It includes mounting screws. These parts attach to a V15 mounting option.

The V15-WALL consists of a V15 V-Panel 12" Touchpanel Display mounted inside of a chassis. It includes mounting screws. These parts attach to a V12 mounting option.

The WMKC-V15 consists of six parts: a mounting plate, chassis, bezel and three sets of mounting screws. The final assembled product is the TPMC-V15-WALL or V15-WALL.

The hardware supplied with the TPMC-V15-WALL and V15-WALL is listed in the following table.

#### *Supplied Hardware for the TPMC-V15-WALL and V15-WALL*

DESCRIPTION	PART NUMBER	QUANTITY
Bezel, Plastic, V15, White (TPMC-V15-WALL-W and V15-WALL-W only)	4509722	1
Bezel, Plastic, V15, Black (TPMC-V15-WALL-B and V15-WALL-B only)	4509723	1
Screw, #06-32 x 1 1/2"	2007254	6

The hardware supplied with the WMKC-V15 is listed in the following table.

#### *Supplied Hardware for the WMKC-V15*

DESCRIPTION	PART NUMBER	QUANTITY
Bezel, Plastic, White (WMKC-V15-W only)	4509722	1
Bezel, Plastic, Black (WMKC-V15-B only)	4509723	1
Chassis, Wall Mount	2023922	1
Bracket, VESA Mount	2023927	1
Screw, #08-32 x 1/4"	2007263	4
Screw, #06-32 x 1 1/2"	2007254	6
Screw, M4 x 12 mm	2023678	4

For simplicity within this guide, the color designation is omitted and TPMC-V15-WALL, V15-WALL and WMKC-V15 are used except where noted.

## Installation

This section provides assembly and installation procedures for the Wall Mount and Chassis Wall Mount Kits. The “WMKC-V15 Procedure” starts below and the “TPMC-V15-WALL and V15-WALL Procedure” starts on page 10. Be sure to review each procedure before starting.

### ***WMKC-V15 Procedure***

This section provides the necessary steps for the assembly of a TPMC-V15 Integrated 15” Touchpanel or V15 V-Panel 15” Touchpanel Display into a wall mount chassis. Review the procedure and complete the steps in the order provided. The only tool required is a #2 Phillips screwdriver.

---

**NOTE:** If converting a TPMC-V15-TILT or V15-TILT, remove the plastic cover on the back of the panel to expose the tilt arm mounting assembly. Then remove the four screws that hold the tilt arm with a #2 Phillips screwdriver. Follow the procedure below to mount the TPMC-V15 or V15 into the chassis wall mount kit.

---

1. Attach the symmetrical VESA mounting bracket (2023927) to the rear of the touchpanel using the four included M4 x 12 mm screws (2023678). Make sure that the stand offs are facing away from the rear of the touchpanel. Do not over tighten screws.
2. Place the wall mount chassis (2023922) over the back of the touchpanel. The large cutout in the chassis should align with the bottom of the touchpanel. Align the screw holes and secure the touchpanel with the four included #08-32 x 1/4” Phillips head screws (2007263). The finished product is essentially the TPMC-V15-WALL or V15-WALL. Refer to the illustration on the following page for visual guidance.

*WMKC-V15 Assembly (Exploded View)*

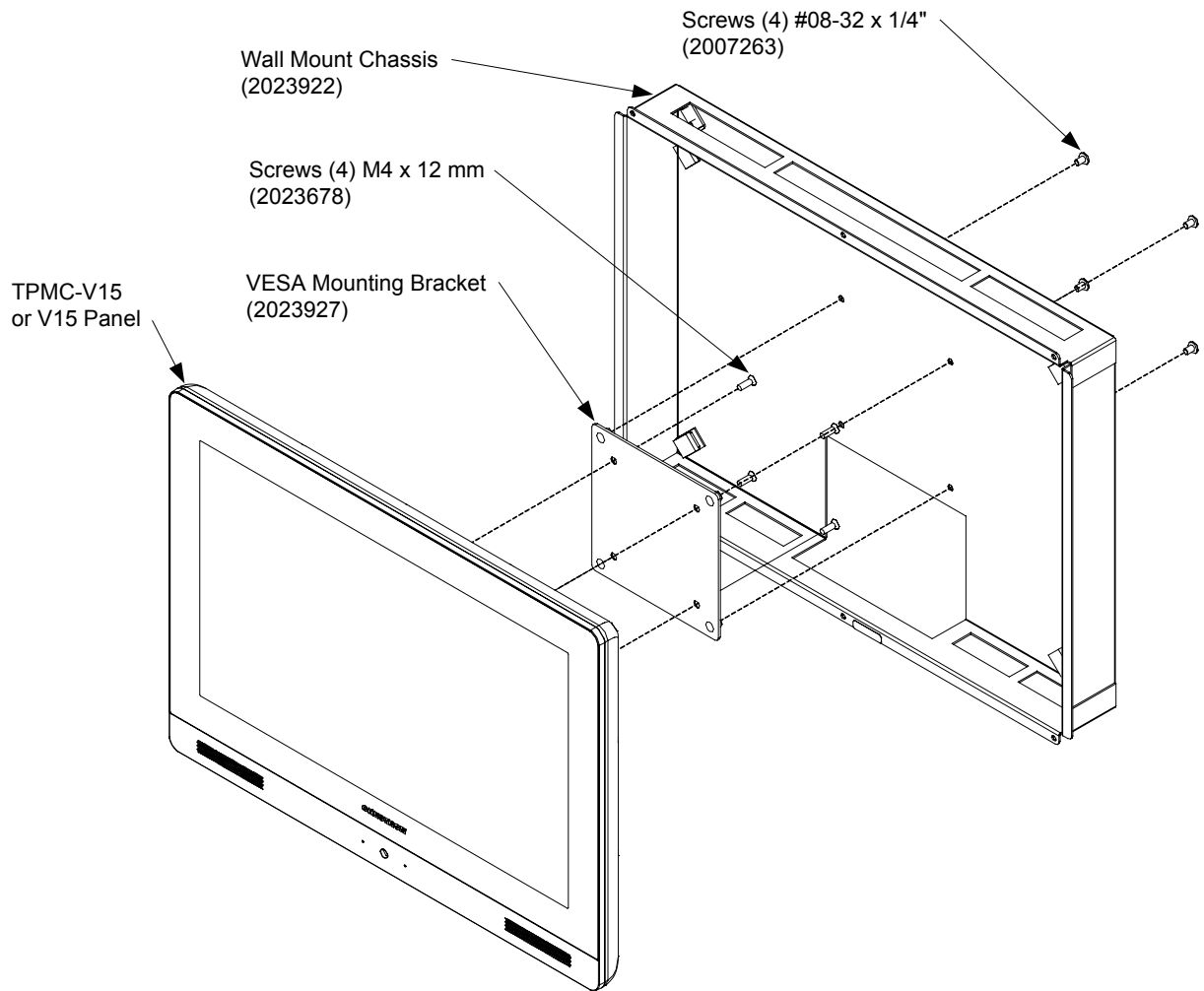

3. Follow the TPMC-V15-WALL and V15-WALL procedure on the following page to install the assembly into a V15 mounting option.

### ***TPMC-V15-WALL and V15-WALL Procedure***

This section provides the necessary steps for the installation of the TPMC-V15-WALL or V15-WALL into a V15 mounting option. It is assumed that wiring has been run and an appropriate V15 mounting option has been installed according to the instructions in the latest version of its Installation Guide.

Complete the steps in the order provided. The only tool required and not supplied is a #2 Phillips screwdriver.

---

**CAUTION:** Allow an air gap of at least 12 inches (305 mm) in the wall cavity above and below the touchpanel for heat dissipation.

**NOTE:** The illustration in this procedure shows the installation of the TPMC-V15-WALL or V15-WALL with the PMK-V15. Even though the illustration only shows the PMK-V15, the procedure is identical for other V15 mounting options.

---

1. If a cover plate is attached, use a #2 Phillips screwdriver to loosen and remove the six screws and plate.
2. Connect all required cables to the touchpanel. Refer to “Hardware Hookup” section of the TPMC-V12 & TPMC-V15 Operations Guide (Doc. 6940) or the V12 & V15 Operations Guide (Doc. 6806). Both are available from the Crestron Web site.
3. Insert the touchpanel (without its bezel) into the mounting option and align the six screw holes. Do not handle touchpanel by the screen.
4. Insert and tighten the six included #06-32 x 1 1/2” screws (2007254) (finger tight and then using a #2 Phillips screwdriver, tighten an additional 1/8-turn). Refer to the illustration on the following page.

*Secure TPMC-V15-WALL or V15-WALL to the Mounting Option*

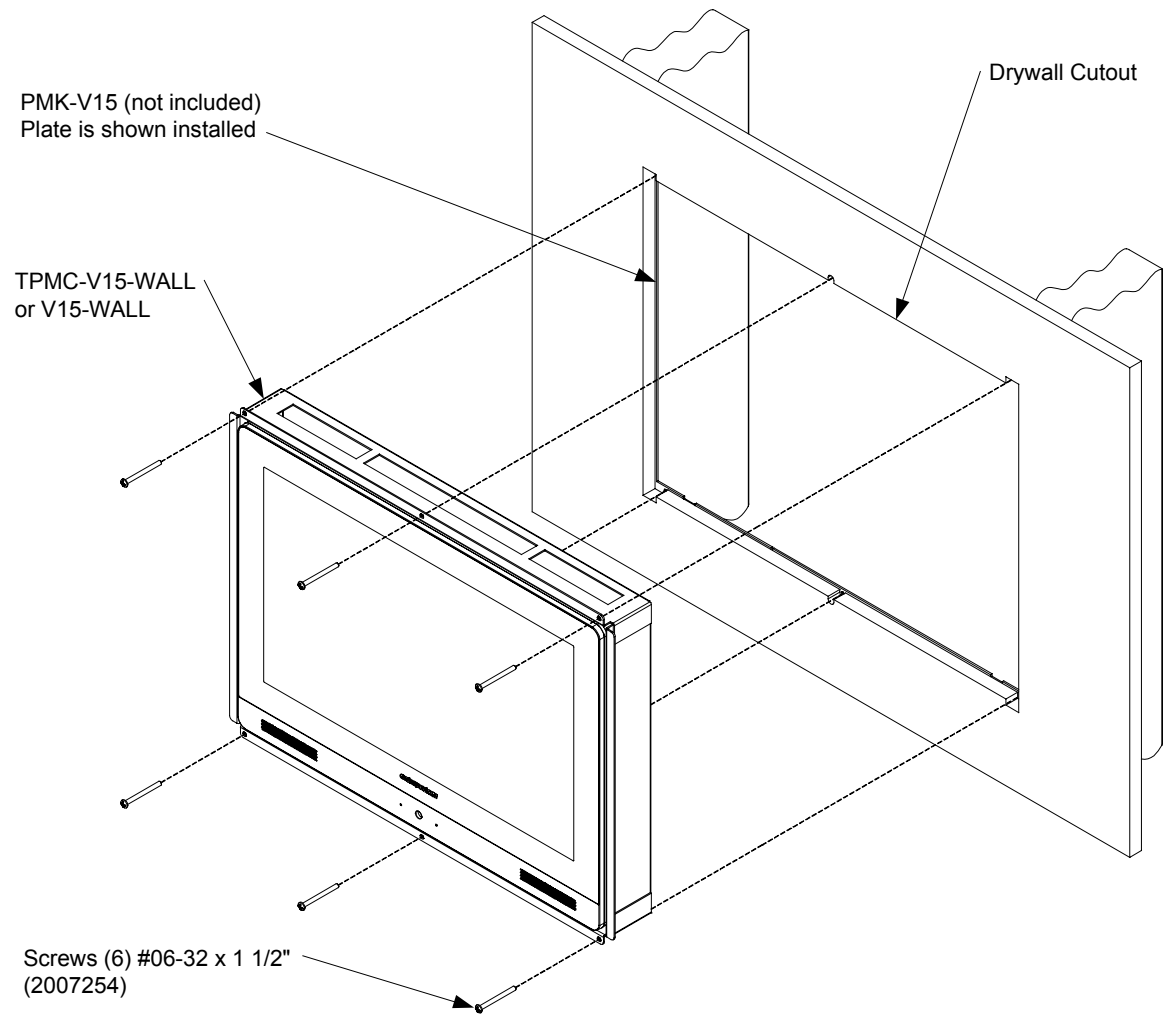

5. Observing the orientation of the word **BOTTOM** on the back of the magnetic bezel, place the bezel over the touchpanel. Refer to the illustration on the following page.

*Mount Bezel to TPMC-V15 or V15 Touchpanel*

Bezel  
(4509723 or 4509722)

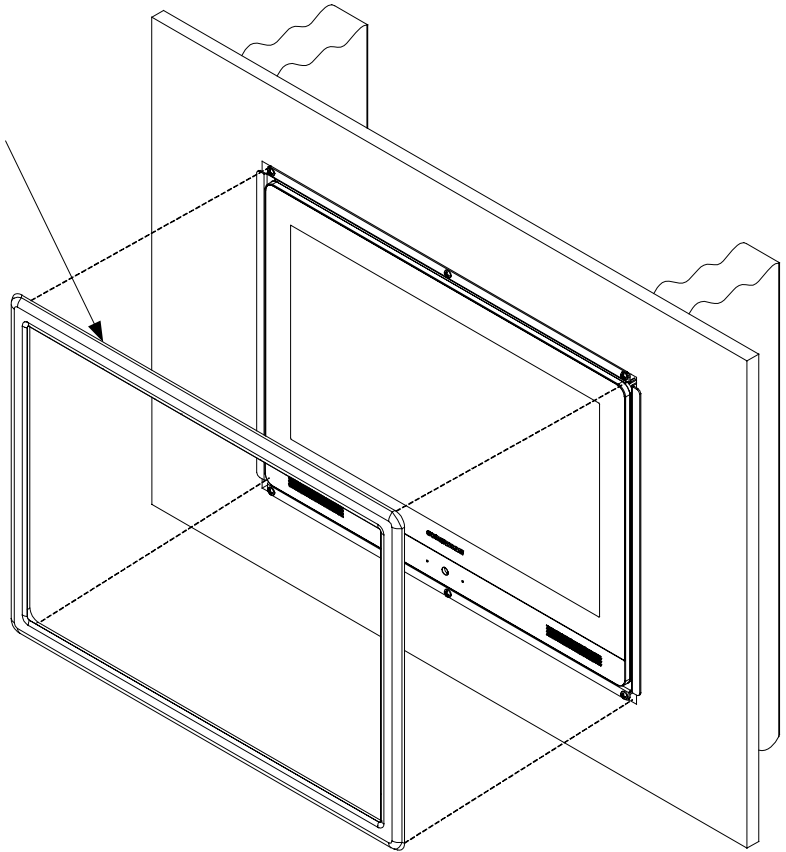



---

## Resources

### Reference Documents

The latest version of all documents mentioned within the guide can be obtained from the Crestron Web site ([www.crestron.com/manuals](http://www.crestron.com/manuals)). This link will provide a list of product manuals arranged in alphabetical order by model number.

#### *List of Related Reference Documents*

DOCUMENT TITLE
BB-V15 Pre-Construction Wall Mount Back Box
MMK-V15 and WMKM-V15 Mud Mount Kits
PMK-V15 Pre-Construction Mounting Kit
TPMC-V12 & TPMC-V15 Integrated 12" & 15" Touchpanels
V12 & V15 V-Panel 12" & 15" Touchpanel Displays
WMKT-V15 Trim Ring Mount Kit

### Further Inquiries

If you cannot locate specific information or have questions after reviewing this guide, please take advantage of Crestron's award winning customer service team by calling Crestron at 1-888-CRESTRON [1-888-273-7876].

You can also log onto the online help section of the Crestron Web site ([www.crestron.com/onlinehelp](http://www.crestron.com/onlinehelp)) to ask questions about Crestron products. First-time users will need to establish a user account to fully benefit from all available features.

### Future Updates

As Crestron improves functions, adds new features and extends the capabilities of the TPMC-V15-WALL, V15-WALL and WMKC-V15, additional information may be made available as manual updates. These updates are solely electronic and serve as intermediary supplements prior to the release of a complete technical documentation revision.

Check the Crestron Web site periodically for manual update availability and its relevance. Updates are identified as an "Addendum" in the Download column.

---

## Return and Warranty Policies

### Merchandise Returns / Repair Service

1. No merchandise may be returned for credit, exchange or service without prior authorization from CRESTRON. To obtain warranty service for CRESTRON products, contact an authorized CRESTRON dealer. Only authorized CRESTRON dealers may contact the factory and request an RMA (Return Merchandise Authorization) number. Enclose a note specifying the nature of the problem, name and phone number of contact person, RMA number and return address.
2. Products may be returned for credit, exchange or service with a CRESTRON Return Merchandise Authorization (RMA) number. Authorized returns must be shipped freight prepaid to CRESTRON, 6 Volvo Drive, Rockleigh, N.J. or its authorized subsidiaries, with RMA number clearly marked on the outside of all cartons. Shipments arriving freight collect or without an RMA number shall be subject to refusal. CRESTRON reserves the right in its sole and absolute discretion to charge a 15% restocking fee plus shipping costs on any products returned with an RMA.
3. Return freight charges following repair of items under warranty shall be paid by CRESTRON, shipping by standard ground carrier. In the event repairs are found to be non-warranty, return freight costs shall be paid by the purchaser.

### CRESTRON Limited Warranty

CRESTRON ELECTRONICS, Inc. warrants its products to be free from manufacturing defects in materials and workmanship under normal use for a period of three (3) years from the date of purchase from CRESTRON, with the following exceptions: disk drives and any other moving or rotating mechanical parts, pan/tilt heads and power supplies are covered for a period of one (1) year; touchscreen display and overlay components are covered for 90 days; batteries and incandescent lamps are not covered.

This warranty extends to products purchased directly from CRESTRON or an authorized CRESTRON dealer. Purchasers should inquire of the dealer regarding the nature and extent of the dealer's warranty, if any.

CRESTRON shall not be liable to honor the terms of this warranty if the product has been used in any application other than that for which it was intended or if it has been subjected to misuse, accidental damage, modification or improper installation procedures. Furthermore, this warranty does not cover any product that has had the serial number altered, defaced or removed.

This warranty shall be the sole and exclusive remedy to the original purchaser. In no event shall CRESTRON be liable for incidental or consequential damages of any kind (property or economic damages inclusive) arising from the sale or use of this equipment. CRESTRON is not liable for any claim made by a third party or made by the purchaser for a third party.

CRESTRON shall, at its option, repair or replace any product found defective, without charge for parts or labor. Repaired or replaced equipment and parts supplied under this warranty shall be covered only by the unexpired portion of the warranty.

Except as expressly set forth in this warranty, CRESTRON makes no other warranties, expressed or implied, nor authorizes any other party to offer any warranty, including any implied warranties of merchantability or fitness for a particular purpose. Any implied warranties that may be imposed by law are limited to the terms of this limited warranty. This warranty statement supersedes all previous warranties.

This page is intentionally left blank.



**Crestron Electronics, Inc.**  
15 Volvo Drive Rockleigh, NJ 07647  
Tel: 888.CRESTRON  
Fax: 201.767.7576  
[www.crestron.com](http://www.crestron.com)

---

**Installation Guide – DOC. 6884B**  
**(2025227)**  
**02.11**  
Specifications subject to  
change without notice.