

FlipTop™ FT2 Series Cable Management System, 1200 Size, Mechanical, Pass-Through Lid

The Crestron® [FT2-1200-MECH-PTL](#) FlipTop™ cable management system installs into a table or other horizontal surface to provide modular connectivity. It features a retracting lid that disappears within the enclosure. When the lid is retracted, nine module slots are arranged in one row. The flexible modular design may also be customized with an assortment of Crestron accessories, and the pass-through lid style allows cables to be fully extended while the lid is closed.

For more information about the accessories, please visit www.crestron.com/Crestron-FlipTops. To configure your FlipTop, launch the [FlipTop Configuration Tool](#).



In the Box

1 FT2-1200-MECH-PTL

Additional Items

- 2 Locking Bars with screws and gaskets (4532619)
- 1 Cutout Template (4528347)

FlipTop™ FT2 Series Cable Management System, 1200 Size, Mechanical, Pass-Through Lid



Mount the FlipTop Assembly

A mounting hole is required for an FT2-1200-MECH-PTL installation. Use the included template to cut a mounting hole for new installations.

When determining the location for the FT2 assembly, consider where users will be seated and their proximity to the FT2 assembly's modules and retractors. Refer to the [FT2A-CBLR-GR](#) series cable retractors for above-the-table cable pull-out lengths.

Cut the Mounting Hole

A saw and the included cutout template are required to cut the mounting hole.

1. Check the table surface and the area beneath the table. Clear any obstructions that may impede the installation or functionality of the FT2 assembly, retractors, and accessories.
2. Using the included cutout template, trace an outline of the mounting hole onto the table.
3. Cut the mounting hole in the table with an appropriate saw.

Secure the FlipTop Assembly

To secure the FT2-1200-MECH-PTL to the table surface:

1. Gently remove the bezel before securing the FT2 assembly to the table. It is held in place with magnets.
2. Ensure that all four swiveling dogs are tucked inside of the FT2 assembly, and then insert the FT2 assembly into the mounting hole until the top lip is flush with the table surface.
3. Carefully tighten the four swiveling dogs in each corner of the FlipTop assembly clockwise until the FT2 assembly is secured in place against the table. Do not overtighten the swiveling dogs.

CAUTION: A screwdriver or manual torque screwdriver at its lowest setting may be used to tighten the swiveling dogs. Avoid stripping the swiveling dogs and damaging the table.

If removing the FT2-1200-MECH-PTL from the table, ensure that the screwdriver rotation is set correctly before loosening the swiveling dogs.

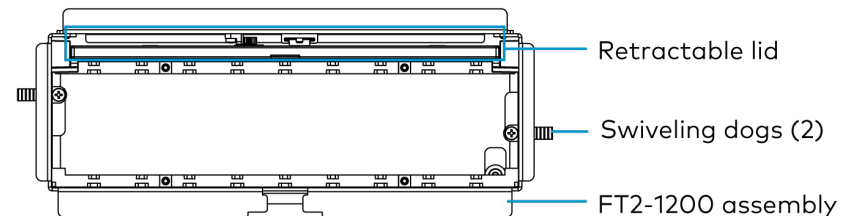

FlipTop™ FT2 Series Cable Management System, 1200 Size, Mechanical, Pass-Through Lid



Install the Modules

All modules are sold separately and not included with the FT2-1200-MECH-PTL FlipTop assembly. Installation procedures for most modules are available in separate product documentation. For more information, refer to the specific product manual located at www.crestron.com/manuals.

The following sections provide best practices and installation procedures for pass-through cable modules and blank plate modules.

Module Best Practices

Follow the best practices below when performing module installation.

- Perform module installation in the following order:
 1. AC Power Outlet Modules ([FT2A-PWR-US](#), [FT2A-PWR-EU](#), [FT2A-PWR-AU](#), [FT2A-PWR-FR](#), [FT2A-PWR-IS](#), [FT2A-PWR-IT](#), [FT2A-PWR-SW](#), [FT2A-PWR-UK](#), and [FT2A-PWR-UN](#))
 2. Retractor modules ([FT2A-CBLR-GR](#) series)
 3. All other modules ([FT2A-CP](#) series, [FT2A-CHGR](#) series, [FT2A-PLT-PT](#), and [FT2A-PLT-BLANK](#))
- Place the FT2A-CBLR-GR modules only at the ends of a module row.
- Dress all cables after installing each module.

Pass-Through Cable Module

The FT2A-PLT-PT pass-through modules (sold separately) enable FT2-CBL-PT pass-through cables (sold separately) and other types of interface cables to be installed within the FT2-1200-MECH-PTL. Each FT2A-PLT-PT cable module is packaged with a nylon grommet and a cable plate. An empty module slot in the FT2-1200-MECH-PTL and an FT2-CBL-PT series or other interface cable are required for installation.

Installing the Pass-Through Cable Module with 4K Cables

The included grommet is not needed when installing most 4K cables. If the cable is 10 mm or thinner, the grommet may be used.

1. Push the connector end of the cable through the hole in the cable plate.
2. Insert the cable plate into one of the three slots in the pass-through module. Choose the appropriate slot based on the length of the cable connector. The top of the connector must sit flush with the top of the module.

NOTES:

- If the connector extends past the top of the pass-through module, the lid cannot close.
- Ensure that the cable moves freely in the module prior to attaching the side plate. The plate is difficult to remove once it is attached.

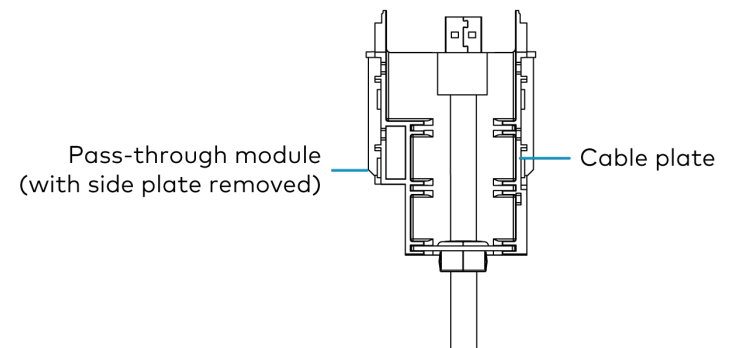

FlipTop™ FT2 Series Cable Management System, 1200 Size, Mechanical, Pass-Through Lid

- Attach the side plate to the module by snapping the plastic clips on the plate into the two slots on the module.

NOTE: When removing the side plate, use a flat-head screwdriver to carefully pry the plastic clips off of the module near the two slots.

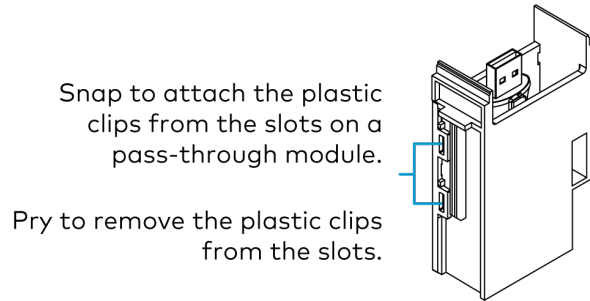

- Feed the other end of the cable through an empty module slot in the FT2 assembly.
- Slide the pass-through cable module into the same module slot as mentioned in the previous step. Use the guide ribs on the front and rear of each module to help position the module in the FT2 assembly.

Installing the Pass-Through Cable Module with Non-4K Cables

The grommet is recommended to use with cables that are 10 mm or thinner.

- Open the grommet.
- Insert a cable into the grommet with the connector facing up toward the user.
- Press the grommet back together to secure the cable inside.
- Push the grommet and cable through the hole in the cable plate.

- Insert the cable plate into one of the three slots in the pass-through module. Choose the appropriate slot based on the length of the cable connector. The top of the connector must sit flush with the top of the module.

NOTES:

- If the connector extends past the top of the pass-through module, the lid cannot close.
- Ensure that the cable moves freely in the module prior to attaching the side plate. The plate is difficult to remove once it is attached.

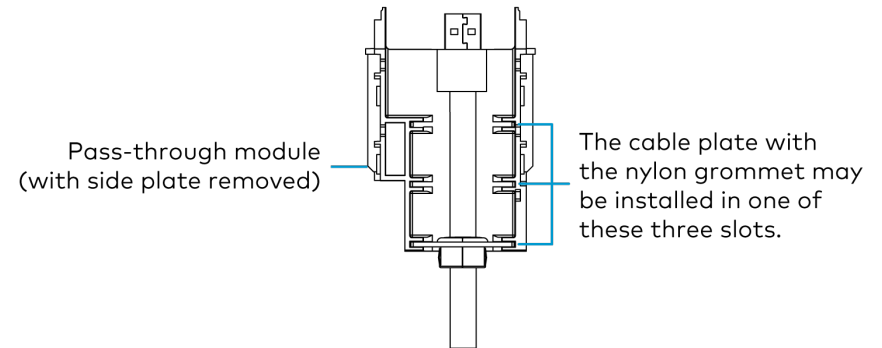

FlipTop™ FT2 Series Cable Management System, 1200 Size, Mechanical, Pass-Through Lid

- Attach the side plate to the module by snapping the plastic clips on the plate into the two slots on the module.

NOTE: When removing the side plate, use a flat-head screwdriver to carefully pry the plastic clips off of the module near the two slots.

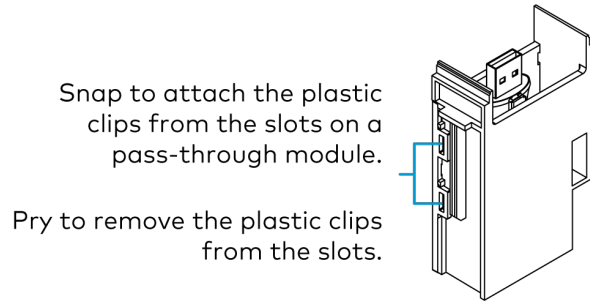

- Feed the other end of the cable through an empty module slot in the FT2 assembly.
- Slide the pass-through cable module into the same module slot as mentioned in the previous step. Use the guide ribs on the front and rear of each module to help position the module in the FT2 assembly.

Install the Blank and Keystone Plate Module

Blank plate modules (sold separately) fill empty slots in module rows, and keystone plate modules (sold separately) allow for cables terminated with standard keystone jacks to be installed in the FT2 assembly. The blank and keystone modules each require one empty module slot for installation.

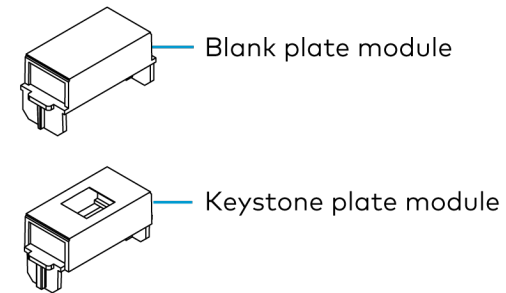

To install a blank or keystone plate module into the FT2-1200-MECH-PTL:

- Slide the blank plate module down into the appropriate module slot. Use the guide ribs on the front and rear of each module to help position it in the FT2 assembly.
- For the keystone plate module, complete the following steps.
 - Snap the cable's keystone jack into the keystone opening in the keystone plate module.
 - Feed the cable down through the empty module slot.
 - Slide the attached keystone plate module down into the same module slot using the front and rear guide ribs to assist with positioning.

FlipTop™ FT2 Series Cable Management System, 1200 Size, Mechanical, Pass-Through Lid



Install the Locking Bars

To install the locking bars:

1. Position the locking bars so that the gasket and screws attached to the locking bars engage the screw holes in the FT2 assembly.
2. Use a screwdriver to secure the locking bar screws to the FT2 assembly.

CAUTION: Do not overtighten the locking bar screws.

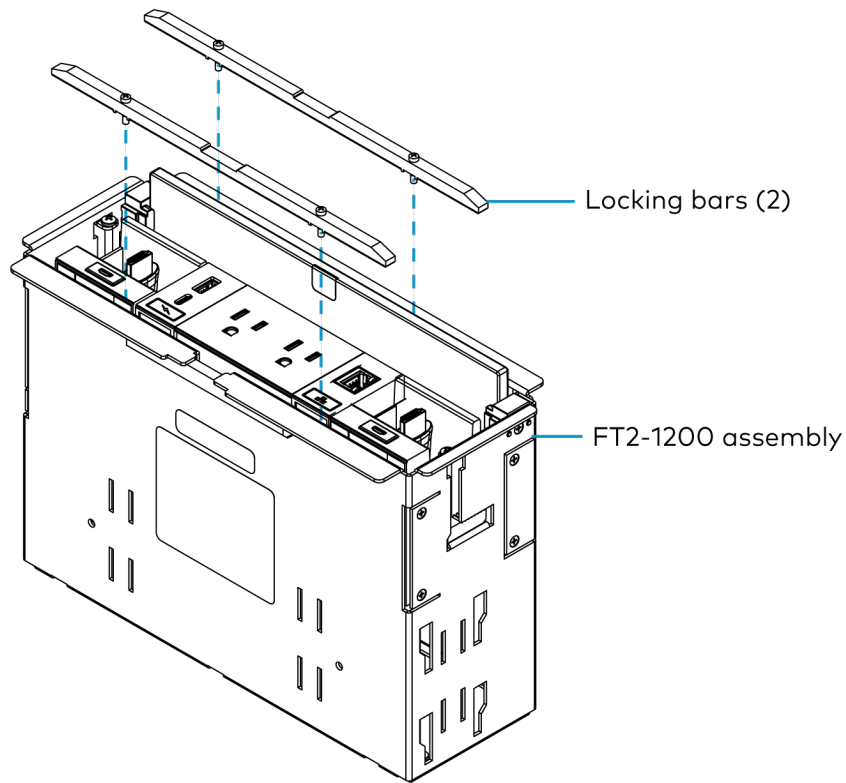

Install the Bezel

Place the bezel onto the FT2 assembly so that the retractable lid fits inside the bezel opening. The bezel is held in place using magnets.

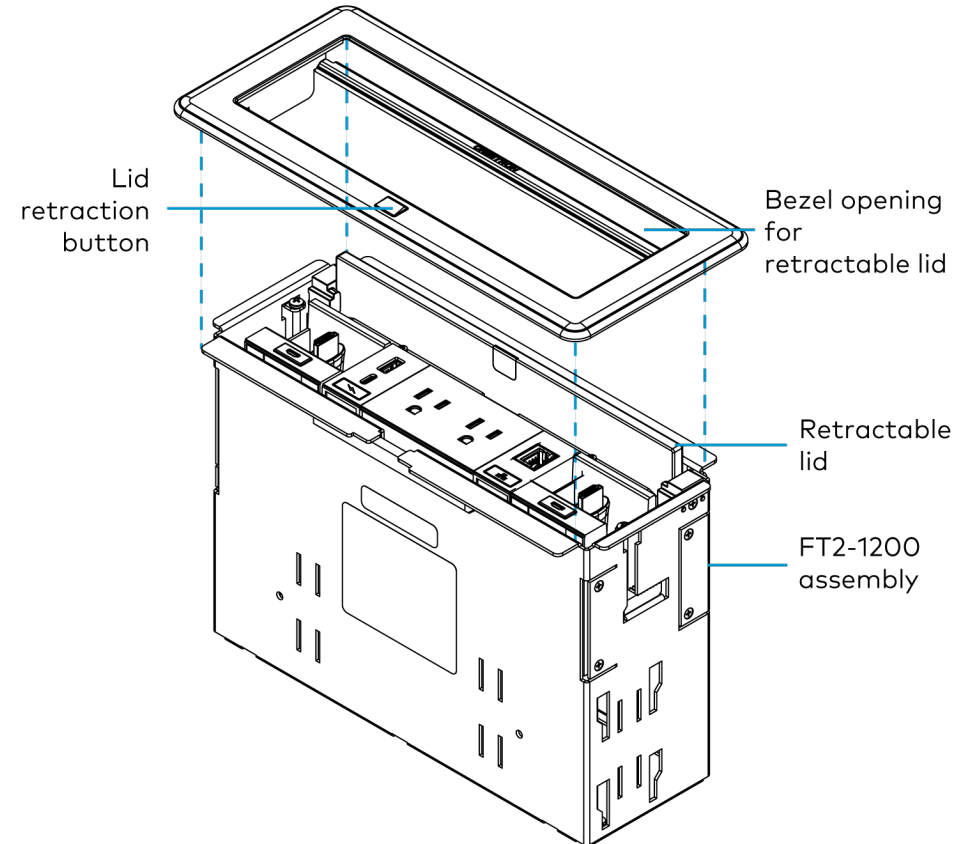

FlipTop™ FT2 Series Cable Management System, 1200 Size, Mechanical, Pass-Through Lid



Operate the FlipTop Assembly

To operate the FT2-1200-MECH-PTL:

1. Open the lid by sliding the lid retraction button away from the FT2 assembly. The lid retracts into the assembly.
2. Access the modules in the FT2 assembly.
3. Close the lid by lifting it vertically and returning it over the FT2 assembly.



Visit the Product Page

Scan the QR code to visit the product page.

FT2-1200-MECH-PTL



www.crestron.com/model/6511656

Additional Information

Original Instructions

The U.S. English version of this document is the original instructions. All other languages are a translation of the original instructions.

Regulatory Models: FT2-1200-MECH-AL, FT2-1200-MECH-B

Crestron product development software is licensed to Crestron dealers and Crestron Service Providers (CSPs) under a limited nonexclusive, nontransferable Software Development Tools License Agreement. Crestron product operating system software is licensed to Crestron dealers, CSPs, and end-users under a separate End-User License Agreement. Both of these Agreements can be found on the Crestron website at www.crestron.com/legal/software_license_agreement.

The product warranty can be found at www.crestron.com/warranty.

The specific patents that cover Crestron products are listed at www.crestron.com/legal/patents.

Certain Crestron products contain open source software. For specific information, visit www.crestron.com/opensource.

Crestron, the Crestron logo, and FlipTop are either trademarks or registered trademarks of Crestron Electronics, Inc. in the United States and/or other countries. Other trademarks, registered trademarks, and trade names may be used in this document to refer to either the entities claiming the marks and names or their products. Crestron disclaims any proprietary interest in the marks and names of others. Crestron is not responsible for errors in typography or photography.

©2021 Crestron Electronics, Inc.

Doc. 9081A

11/05/21