

Crestron **AM-100**  
AirMedia® Presentation Gateway

---

Operations Guide



## Regulatory Compliance

As of the date of manufacture, the AM-100 has been tested and found to comply with specifications for CE marking.



---

## Federal Communications Commission (FCC) Compliance Statement

This device complies with part 15 of the FCC Rules. Operation is subject to the following conditions:

(1) This device may not cause harmful interference and (2) this device must accept any interference received, including interference that may cause undesired operation.

**CAUTION:** Changes or modifications not expressly approved by the manufacturer responsible for compliance could void the user's authority to operate the equipment.

**NOTE:** This equipment has been tested and found to comply with the limits for a Class B digital device, pursuant to part 15 of the FCC Rules. These limits are designed to provide reasonable protection against harmful interference in a residential installation. This equipment generates, uses and can radiate radio frequency energy and, if not installed and used in accordance with the instructions, may cause harmful interference to radio communications. However, there is no guarantee that interference will not occur in a particular installation. If this equipment does cause harmful interference to radio or television reception, which can be determined by turning the equipment off and on, the user is encouraged to try to correct the interference by one or more of the following measures:

- Reorient or relocate the receiving antenna.
- Increase the separation between the equipment and receiver.
- Connect the equipment into an outlet on a circuit different from that to which the receiver is connected.
- Consult the dealer or an experienced radio/TV technician for help.

---

## Industry Canada (IC) Compliance Statement

CAN ICES-3(B)/NMB-3(B)

---

Crestron software, including without limitation, product development software and product operating system software is licensed to Crestron dealers and Crestron Service Providers (CSPs) under a limited non-exclusive, non-transferable license pursuant to a separate end-user license agreement. The terms of this end-user license agreement can be found at [www.crestron.com/legal/software\\_license\\_agreement](http://www.crestron.com/legal/software_license_agreement).

Product warranty can be found at [www.crestron.com/warranty](http://www.crestron.com/warranty).

The specific patents that cover Crestron products are listed at [patents.crestron.com](http://patents.crestron.com).

Certain Crestron products contain open source software. For specific information, please visit [www.crestron.com/opensource](http://www.crestron.com/opensource).

Crestron, the Crestron logo, AirMedia, Crestron Connected, and Crestron Fusion are either trademarks or registered trademarks of Crestron Electronics, Inc. in the United States and/or other countries. App Store, iTunes, and Mac are either trademarks or registered trademarks of Apple Inc. in the United States and/or other countries. IOS is either a trademark or registered trademark of Cisco Technology, Inc. in the United States and/or other countries. Android and Google Play are either trademarks or registered trademarks of Google Inc. in the United States and/or other countries. Windows is either a trademark or registered trademark of Microsoft Corporation in the United States and/or other countries. Other trademarks, registered trademarks, and trade names may be used in this document to refer to either the entities claiming the marks and names or their products. Crestron disclaims any proprietary interest in the marks and names of others. *Crestron is not responsible for errors in typography or photography.*

This document was written by the Technical Publications department at Crestron.  
© 2017 Crestron Electronics, Inc.

# Contents

<b>AirMedia® Presentation Gateway: AM-100</b>	<b>1</b>
Setup .....	1
Supplied Hardware .....	1
Installation .....	1
Configuration .....	3
System Status .....	6
Device Setup .....	7
Network Setup .....	9
Crestron Services Setup .....	10
OSD Setup .....	13
SNMP Setup .....	15
Device Services .....	17
Change Password .....	17
Firmware Upgrade .....	18
Remote View Setup .....	20
Reset to Default .....	21
Reboot System .....	22
Operation .....	23
Run the AM-100 Client .....	24
Control the Presentation .....	26
Configure Basic Presentation Settings .....	27
Quad View .....	29
View a Presentation Remotely .....	29
Moderator Controls .....	31
Login .....	31
Control the Display Layout .....	33
Hardware Reset .....	35



# AirMedia<sup>®</sup> Presentation Gateway: AM-100

---

## Setup

### Supplied Hardware

A wall-mount bracket is included to mount the AM-100 to a surface. The hardware supplied with the AM-100 is listed in the following table.

#### *Supplied Hardware for the AM-100*

DESCRIPTION	QUANTITY
Bracket	1
Screw	2
Washer	2

### Installation

#### *Ventilation*

The AM-100 should be used in a well-ventilated area.

To prevent overheating, do not operate this product in an area that exceeds the environmental temperature range for this product. Consider using forced air ventilation to reduce overheating. Consideration must be given if the device is installed in a closed or multiunit rack assembly, since the operating ambient temperature of the environment may be greater than the room ambient temperature. Contact with thermal insulating materials should be avoided on all sides of the unit.

**Wall  
Mounting**

The AM-100 can be mounted using the included wall-mount bracket. Refer to the following illustration for installation instructions.

***Attach the Wall-Mount Bracket***

Install the screw and washer into the unit.

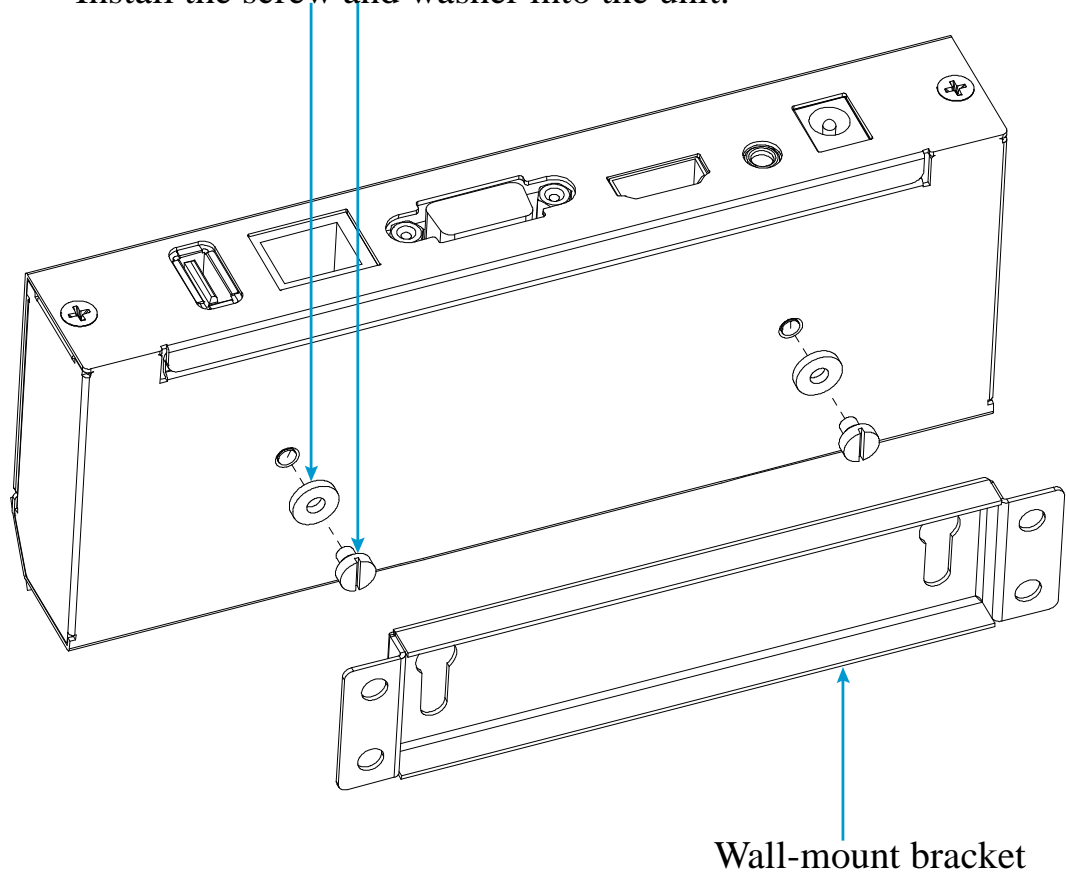

---

## Configuration

Make all connections as described in AM-100 Quickstart Guide (Doc. 7464) at [www.crestron.com/manuals](http://www.crestron.com/manuals). The connected display device shows the AM-100 welcome screen.

### *AM-100 Welcome Screen*

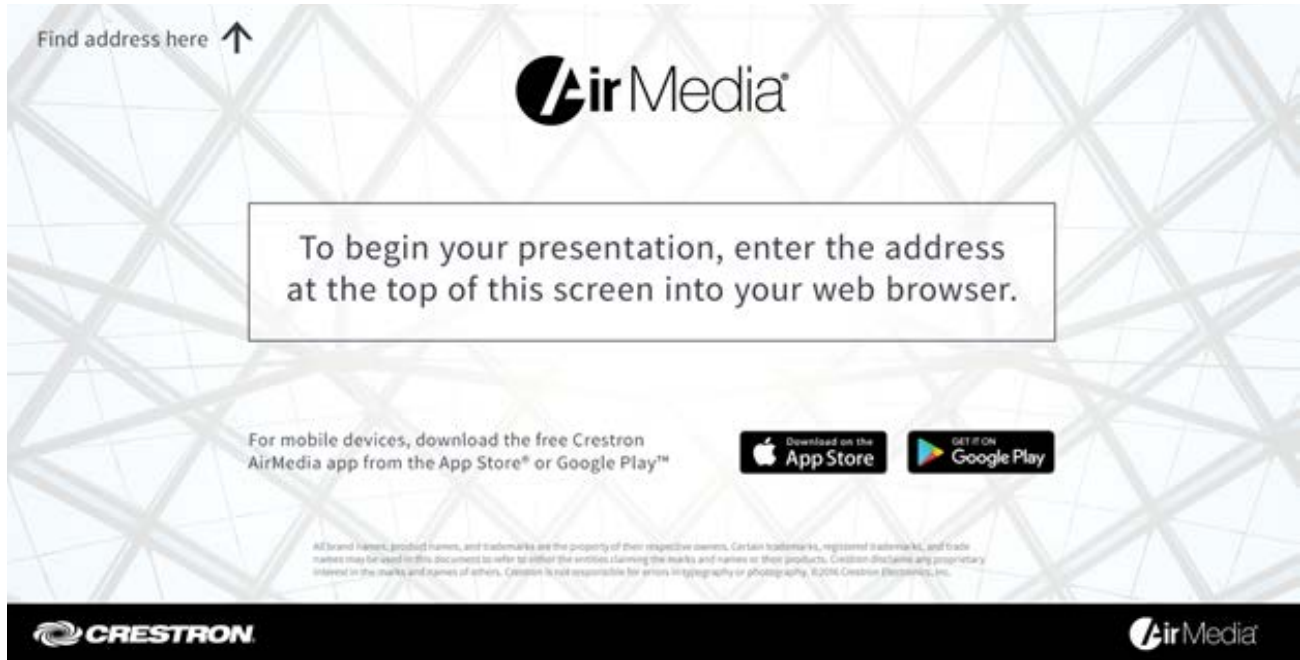

1. Open a web browser on the computer, and navigate to the web address or the IP address that is displayed on the top left of the AM-100 welcome screen. The download screen is displayed.

---

**NOTE:** By default, the AM-100 displays the IP address in parentheses to assist in the configuration of the device. The IP address can be hidden so that the end user sees only a friendly URL (i.e., <http://AirMedia-019647>). For details, refer to “OSD Setup” on page 13.

---

## Download Screen

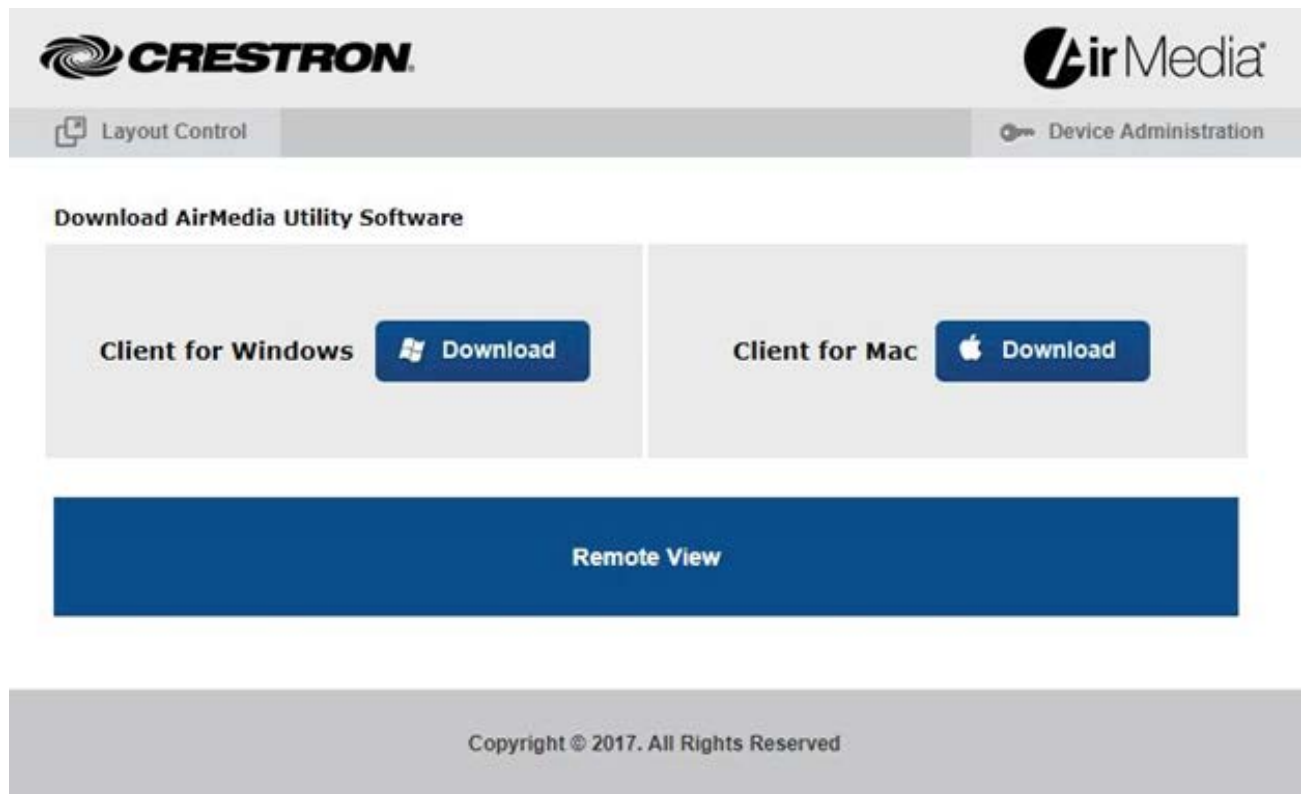

2. Click **Device Administration**. The admin login screen is displayed.

---

**NOTE:** Prior to displaying the admin login screen, the web browser displays a security warning message about the security certificate. It is safe to ignore this warning as long as the user verifies that the browser's address bar indicates the correct IP address or hostname.

---



*Admin Login Screen*



3. Enter the admin password (the default password is “admin”) and click **Login**. The **Device Administration** menu showing the **System Status** screen is displayed.

*Device Administration Menu Showing the System Status Screen*

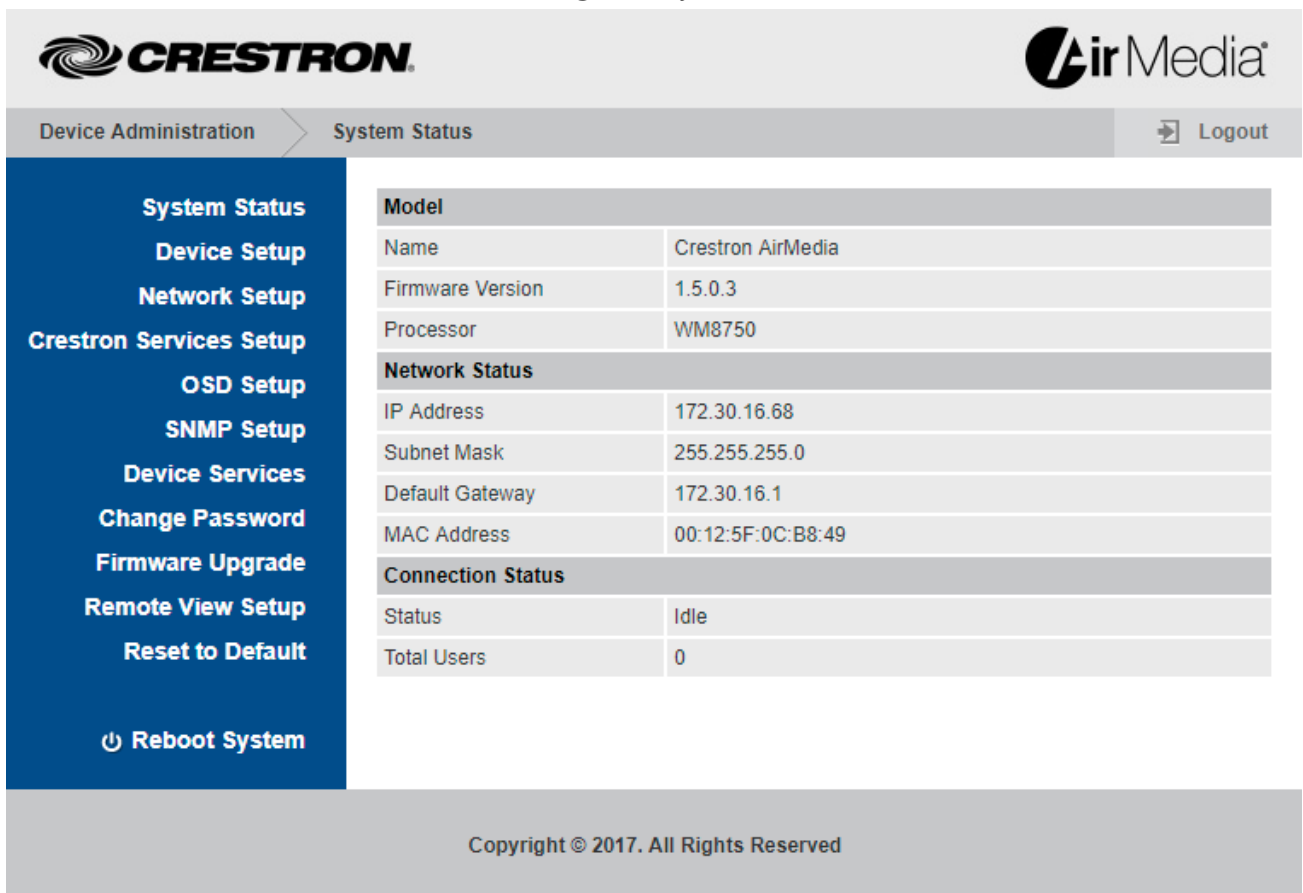

---

**NOTE:** Changes made in any section of the **Device Administration** menu require that the AM-100 be rebooted for the settings to take effect. For details, refer to “Reboot System” on page 22 for details.

---

The **Device Administration** menu is divided into 12 sections:

- **System Status** displays the operational status of the AM-100.
- **Device Setup** sets the AM-100’s output resolution, under-scan setting, and access code.
- **Network Setup** sets the AM-100’s parameters for operating in a network environment.
- **Crestron Services Setup** sets the AM-100’s parameters for operating in a Crestron® network environment.
- **OSD Setup** configures the AM-100’s on-screen display.
- **SNMP Setup** configures the AM-100 to use the Simple Network Management Protocol (SNMP).
- **Device Services** enables and disables remote viewing, SNMP, and other features.
- **Change Password** changes the admin password.
- **Firmware Upgrade** imports or exports the system configuration to match other AM-100 devices and upgrades the AM-100’s firmware.
- **Remote View Setup** specifies the auto-refresh interval.
- **Reset to Default** resets the AM-100 to the default settings.
- **Reboot System** reboots the AM-100.

## System Status

Click **System Status** to display the operational status of the AM-100.

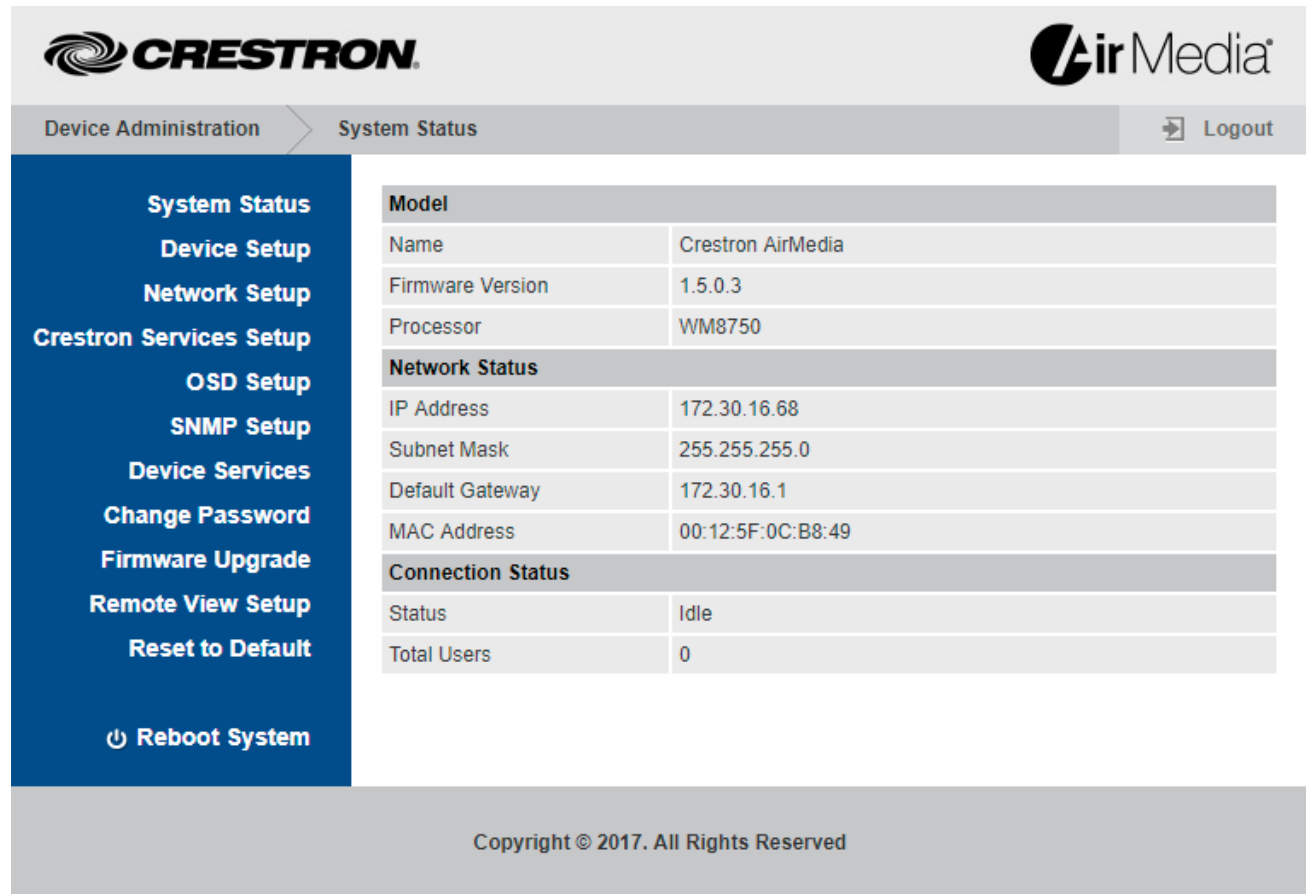
*Device Administration Menu Showing the System Status Screen*

The screenshot shows the Crestron AirMedia System Status screen. The interface includes a navigation menu on the left and a main content area displaying system information.

Model	
Name	Crestron AirMedia
Firmware Version	1.5.0.3
Processor	WM8750
Network Status	
IP Address	172.30.16.68
Subnet Mask	255.255.255.0
Default Gateway	172.30.16.1
MAC Address	00:12:5F:0C:B8:49
Connection Status	
Status	Idle
Total Users	0

Copyright © 2017. All Rights Reserved

The **System Status** screen displays the device's name (hostname), firmware version, network status (IP address, subnet mask, default gateway, and MAC address), and connection status.

## Device Setup

Click **Device Setup** to configure the output resolution, under-scan setting, and access code.

*Device Administration Menu Showing the Device Setup Screen*

The screenshot displays the AirMedia web interface. At the top, the Crestron logo is on the left and the AirMedia logo is on the right. Below the logos, there are two tabs: "Device Administration" and "Device Setup". A "Logout" button is visible in the top right corner. On the left side, there is a dark blue navigation menu with the following items: System Status, Device Setup (highlighted), Network Setup, Crestron Services Setup, OSD Setup, SNMP Setup, Device Services, Change Password, Firmware Upgrade, Remote View Setup, Reset to Default, and Reboot System. The main content area is titled "Device Setup" and contains two sections. The "Login Code Setup" section has a "Code" field with three radio button options: "Disabled", "Random", and "Use the following code" (with a text input field containing "6789" and "(0-9)" next to it, and a "Set" button). The "Device Setup" section has two rows: "Output Resolution" with a dropdown menu set to "Auto Detect (HDMI)", and "Under Scan" with four radio button options: "0%", "2.5%", "5%", and "7.5%". At the bottom right of the settings area, there are "Apply" and "Cancel" buttons. At the very bottom of the page, there is a copyright notice: "Copyright © 2017. All Rights Reserved".

## Code

A code can be used to limit access to the AM-100. The code feature can be disabled, randomly generated, or fixed to a specific value.

Select one of the following options from the **Code** section to specify how the access code is used:

- **Disabled** allows any user with the AM-100's IP address or hostname to open a client connection without entering an access code.
- **Random** sets the AM-100 to randomly generate an access code. A new code is generated when the last connected presenter disconnects from the AM-100. The access code is displayed on the top right of the AM-100 welcome screen as shown on page 3.
- **Use the following code** sets the AM-100 to display a user-specified, four-digit access code. Enter a code and click **Set**. The access code is displayed on the top right of the AM-100 welcome screen as shown on page 3.

Click **Apply** to apply any changes. Click **Cancel** to cancel.

### Output Resolution

Select a resolution setting from the **Output Resolution** drop-down menu.

Click **Apply** to apply any changes. Click **Cancel** to cancel.

### Under Scan

Select an amount of under scan to be applied to the displayed image.

Click **Apply** to apply any changes. Click **Cancel** to cancel.

## Network Setup

Click **Network Setup** to configure the AM-100's parameters for operating in a network environment.

### Device Administration Menu Showing the Network Setup Screen

The screenshot displays the Crestron AirMedia web interface. At the top, the Crestron and AirMedia logos are visible. Below the logos, there is a navigation bar with 'Device Administration' and 'Network Setup' tabs, and a 'Logout' button. A sidebar on the left contains a list of system management options: System Status, Device Setup, Network Setup (highlighted), Crestron Services Setup, OSD Setup, SNMP Setup, Device Services, Change Password, Firmware Upgrade, Remote View Setup, Reset to Default, and Reboot System. The main content area is titled 'Network Setup' and contains the following configuration fields:

Host Name and Domain Name	Host Name	<input type="text" value="AM100-14"/>			
	Domain Name	<input type="text"/>			
Note: For maximum compatibility, host names 15 characters or fewer are recommended. Maximum host name length is 32 characters. Allowed characters: [0-9], [A-Z], [a-z], [-].					
IP Setup	<input checked="" type="radio"/> Obtain an IP address automatically <input type="radio"/> Use the following IP address				
	IP Address	<input type="text" value="172"/>	<input type="text" value="30"/>	<input type="text" value="74"/>	<input type="text" value="174"/>
	Subnet Mask	<input type="text" value="255"/>	<input type="text" value="255"/>	<input type="text" value="252"/>	<input type="text" value="0"/>
	Default Gateway	<input type="text" value="172"/>	<input type="text" value="30"/>	<input type="text" value="74"/>	<input type="text" value="1"/>
	DNS Server	<input type="text" value="192"/>	<input type="text" value="168"/>	<input type="text" value="200"/>	<input type="text" value="133"/>

At the bottom right of the form are 'Apply' and 'Cancel' buttons. The footer of the page reads 'Copyright © 2017. All Rights Reserved'.

## ***Hostname and Domain Name***

Use a hostname and domain name as an alternative to IP addressing when connecting client computers to the AM-100.

---

**NOTE:** When specifying a hostname, Crestron recommends using a hostname that is less than 15 characters.

**NOTE:** To use a hostname, set the AM-100's **IP Setup** to **Obtain an IP address automatically** or, if using a static IP address, specify the domain name in the **Domain Name** field.

---

Enter a hostname (less than 15 characters) in the **Hostname** field and a domain name (optional) in the **Domain Name** field.

Click **Apply** to apply any changes. Click **Cancel** to cancel.

## ***IP Setup***

In the **IP Setup** section, the IP address, subnet mask, default gateway, and DNS server of the AM-100 can be set. The settings can be set manually or obtained from a DHCP server.

Select **Obtain an IP address automatically** to use a DHCP server to provide the IP address, subnet mask, default gateway, and DNS server. Otherwise, select **Use the following IP address** and enter the Ethernet parameters.

Click **Apply** to apply any changes. Click **Cancel** to cancel.

## **Crestron Services Setup**

Click **Crestron Services Setup** to configure the AM-100 for operation in a Crestron network environment.

*Device Administration Menu Showing the Crestron Services Setup Screen*

The screenshot displays the 'Crestron Services Setup' interface. On the left is a blue navigation menu with the following items: System Status, Device Setup, Network Setup, Crestron Services Setup (highlighted), OSD Setup, SNMP Setup, Device Services, Change Password, Firmware Upgrade, Remote View Setup, Reset to Default, and a Reboot System button. The main content area is titled 'Crestron Services Setup' and features a 'Logout' button in the top right. It is divided into three sections:

- Crestron Control System:** Includes fields for IP Address or Host name, IP ID (dropdown menu set to 05), Port (text box with 41794), and Communication Status (Offline).
- Fusion Server:** Includes fields for IP Address or Host name, IP ID (dropdown menu set to 02), Port (text box with 41794), and Communication Status (Offline).
- Crestron Connected® Device:** Includes fields for IP Address or Host name, Communication Status (Offline), Current Source (None), Source (dropdown menu set to None with a Set button), Automatic Power On (radio buttons for Immediately and After Code Entry, with Immediately selected), Power Off Time Out (text box with 0 minutes and a Set button), Power Control (Power On and Power Off buttons), Power Status (Unknown), Lamp Hours (0 hours), and Device Status (No Error).

At the bottom right of the form are 'Apply' and 'Cancel' buttons. A footer at the bottom of the page reads 'Copyright © 2017. All Rights Reserved'.

**Crestron Control System**

The **Crestron Control System** section specifies the control system controlling the AM-100.

- **IP Address or Host name** is the IP address or hostname of the Crestron control system. Enter the IP address or hostname of the Crestron control system and click **Apply**.

- **IP ID** identifies the AM-100 in the control system's program. Select the AM-100's IP ID from the drop-down menu and click **Apply**.
- **Port** is the port number used to communicate with the control system.
- **Communication Status** indicates the status of the communication link between the control system and the AM-100.

To apply any changes, click **Apply**. To cancel, click **Cancel**.

### ***Fusion Server***

The **Fusion Server** section specifies the Crestron Fusion<sup>®</sup> server communicating with the AM-100.

- **IP Address or Host name** is the IP address or hostname of the Crestron Fusion server. Enter the IP address or hostname of the Crestron Fusion server and click **Apply**.
- **IP ID** identifies the AM-100 in the Crestron Fusion server's program. Select the AM-100's IP ID from the drop-down menu and click **Apply**.
- **Port** is the port number used to communicate with the Crestron Fusion server.
- **Communication Status** indicates the status of the communication link between the Crestron Fusion server and the AM-100.
- Click **Apply** to apply any changes. Click **Cancel** to cancel.

### ***Crestron Connected Device***

The **Crestron Connected Device** section specifies the Crestron Connected<sup>®</sup> display device that is connected to the AM-100. Once the device is specified, basic status information and controls are displayed.

Enter the IP address or hostname of the Crestron Connected device to specify the Crestron Connected device.

Click **Set** to apply changes to the **Source** and **Power Off Time Out** settings.

Click **Apply** to apply any changes. Click **Cancel** to cancel.

---

**NOTE:** The **Apply** button does not affect changes made to the **Source** and **Power Off Time Out** settings.

---



## OSD Setup

Click **OSD Setup** to specify a logo image to display and to display or hide the AM-100's connection information.

### Device Administration Menu Showing the OSD Setup Screen

The screenshot displays the OSD Setup configuration page. On the left, a blue sidebar menu contains the following items: System Status, Device Setup, Network Setup, Crestron Services Setup, **OSD Setup**, SNMP Setup, Device Services, Change Password, Firmware Upgrade, Remote View Setup, Reset to Default, and Reboot System. The main content area is titled 'OSD Setup' and includes the following sections:

- Change Logo Image:**
  - Logo Image: Default
  - Restore to default button
  - Customized OSD Image source:  Local  HTTP  FTP
  - File Name: Choose File No file chosen
  - Image File Upload button
  - Files must be in JPEG file format. Maximum file size is 510 kilobytes. Please see the manual for additional considerations.
- OSD Timeout:**
  - DO NOT DISTURB:  On  Off
  - When this setting is off, the connection information will be overlaid on the screen whenever a user opens the AirMedia application. When disabled, the connection settings are only displayed when AirMedia idle.
  - 30 Seconds (Range: 0~600 seconds)
- Video Out Timeout:**
  - 0 Minutes (Range: 0~300 minutes)
- Display Option:**
  - Display IP address:  On  Off
  - Display Code:  On  Off
  - Display Host Name:  On  Off
  - Display Domain Name:  On  Off
  - Note: The Display Domain Name option has no effect unless the Display Host Name option is ON.

At the bottom right of the configuration area are 'Apply' and 'Cancel' buttons. The footer of the page reads 'Copyright © 2017. All Rights Reserved'.

## ***Change Logo Image***

The **Change Logo Image** section is used to select the logo image on the AM-100 welcome screen.

- **Logo Image** displays the file name of the logo image. If the default logo image is used, “Default” is displayed.
- **Restore to default** reverts to the default logo image.
- **Customized OSD Image source** allows the user to select a static image file from the connected PC, a website, or an FTP server. Select the desired option and specify the location of the image file.

When choosing a file, follow these guidelines:

⇒ Use logo images in JPEG format.

⇒ Do not exceed a file size of 510 kB.

⇒ For a given native display resolution, use the following table to create a properly sized logo.

### ***Native Display Resolution and Logo Image Size***

<b>Native Display Resolution</b>	<b>Logo Image Size</b>
800 x 600	800 x 500
1280 x 720	1280 x 600
1024 x 768	1024 x 640
1360 x 768	1360 x 640
1280 x 800	1280 x 667
1400 x 900	1400 x 750
1920 x 1080	1920 x 900
1600 x 1200	1600 x 1000

## ***OSD Timeout***

The **OSD Timeout** section specifies how long the connection information is displayed after a presenter connects to the AM-100.

## ***Video Out Timeout***

The **Video Out Timeout** section specifies how long the video output stays on after inactivity.

## ***Display Option***

The **Display Option** section controls how the connection information is displayed.

- ⇒ **Display IP address** sets the AM-100 to display the IP address after the hostname. Select **On** and click **Apply** to display the IP address, or select **Off** and click **Apply** to hide the IP address.
- ⇒ **Display Code** sets the AM-100 to display the access code on the AM-100 welcome screen. Select **On** and click **Apply** to display the access code, or select **Off** and click **Apply** to hide the access code.
- ⇒ **Display Host Name** sets the AM-100 to display the hostname. Select **On** and click **Apply** to display the hostname after the presenter connects to the AM-100, or select **Off** and click **Apply** to hide connection information after the presenter connects to the AM-100.
- ⇒ **Display Domain Name** sets the AM-100 to display the domain name to which the AM-100 is attached when using a hostname to connect with the AM-100 instead of an IP address. To display the domain name when using the AM-100's hostname for connection, select **On** and click **Apply**. To hide the domain name, select **Off** and click **Apply**.

Click **Apply** to apply any changes. Click **Cancel** to cancel.

## **SNMP Setup**

Click **SNMP Setup** to configure the AM-100 to use SNMP.

*Device Administration Menu Showing the SNMP Setup Screen*

The screenshot shows the AirMedia AM-100 Device Administration interface. The top header features the Crestron and AirMedia logos. Below the header, there is a navigation bar with 'Device Administration' and 'SNMP Setup' (the active page), and a 'Logout' button. A left-hand navigation menu lists various system settings, with 'SNMP Setup' highlighted. The main content area is titled 'SNMP' and contains the following configuration fields:

Version	2c ▼
Manager IP	<input type="text"/>
Public Community	public
Private Community	<input type="text"/>
Username	user
Authentication Protocol	MD5 ▼
Authentication Password	<input type="password"/> <input checked="" type="checkbox"/> Hide characters
Privacy Protocol	DES ▼
Privacy Password	<input type="password"/> <input checked="" type="checkbox"/> Hide characters

At the bottom right of the form are 'Apply' and 'Cancel' buttons. The footer of the page reads 'Copyright © 2017. All Rights Reserved'.

- The AM-100 supports SNMP versions 1, 2c, and 3. Select the version from the **Version** drop-down menu.
- The AM-100 uses an IP filter for SNMP connections. When an IP address is specified in the **Manager IP** field, the device accepts an SNMP request only from that IP address. If the field is blank, the SNMP request is honored from any IP address.
- If using SNMP version 3, a user name, authentication protocol, authentication password, privacy protocol, and privacy password must also be specified.

The default settings are as follows: **Version** is set to **2c**, **Public Community** is set to **public**, and **Private Community** is set to **private**. Click **Apply** to apply any changes. Click **Cancel** to cancel.

## Device Services

Click **Device Services** to enable and disable remote viewing, SNMP, and other features.

### *Device Administration Menu Showing the Device Services Screen*

The screenshot shows the Crestron AirMedia Device Administration interface. At the top, there are logos for Crestron and AirMedia. Below the logos, there are navigation tabs for 'Device Administration' and 'Device Services', with 'Device Services' being the active tab. A 'Logout' button is visible in the top right corner. On the left side, there is a vertical navigation menu with the following items: System Status, Device Setup, Network Setup, Crestron Services Setup, OSD Setup, SNMP Setup, Device Services (highlighted), Change Password, Firmware Upgrade, Remote View Setup, Reset to Default, and Reboot System. The main content area is titled 'Server Setup' and contains a table with the following settings:

Web Server	<input checked="" type="radio"/> Enable <input type="radio"/> Disabled
Remote View	<input checked="" type="radio"/> Enable <input type="radio"/> Disabled
SNMP	<input checked="" type="radio"/> Enable <input type="radio"/> Disabled
Crestron Services	<input checked="" type="radio"/> Enable <input type="radio"/> Disabled
Layout Control	<input checked="" type="radio"/> Enable <input type="radio"/> Disabled
Administration Pages	<input checked="" type="radio"/> Enable <input type="radio"/> Disabled
USB Control	<input checked="" type="radio"/> Enable <input type="radio"/> Disabled

At the bottom right of the table, there are 'Apply' and 'Cancel' buttons. At the bottom of the page, there is a copyright notice: 'Copyright © 2017. All Rights Reserved'.

Select **Enable** or **Disabled** for each service listed in **Server Setup**.

**NOTE:** Disabling the administration pages prevents access to the AM-100's configuration screens. These pages can still be enabled by SNMP or the control system connection. However, if SNMP and Crestron Services are disabled as well, the AM-100 must be restored to the original factory settings to gain access to the configuration screens. For details, refer to "Hardware Reset" on page 35.

## Change Password

Click **Change Password** to set a new admin password or layout control password.

*Device Administration Menu Showing the Change Password Screen*

The screenshot displays the AirMedia web interface. At the top, the Crestron logo is on the left and the AirMedia logo is on the right. Below the logos, a navigation bar shows 'Device Administration' and 'Change Password'. A 'Logout' button is in the top right corner. On the left, a blue sidebar menu lists various system settings, with 'Change Password' highlighted. The main content area is divided into two sections: 'Device Administration' and 'Layout Control'. Each section contains two text input fields for 'Enter New Password' and 'Confirm New Password', followed by an 'Apply' button. The footer of the page reads 'Copyright © 2017. All Rights Reserved'.

***Device Administration***

Perform the following to change the admin password:

1. Enter a new password in the **Enter New Password** field.
2. Enter the new password in the **Confirm New Password** field and click **Apply**.

***Layout Control***

Perform the following to change the layout control password:

1. Enter a new password in the **Enter New Password** field.
2. Enter the new password in the **Confirm New Password** field and click **Apply**.

**Firmware Upgrade**

Click **Firmware Upgrade** to import or export device configuration settings or upload new firmware.

*Device Administration Menu Showing the Firmware Upgrade Screen*

The screenshot displays the Crestron AirMedia web interface. At the top, the Crestron logo is on the left and the AirMedia logo is on the right. Below the logos, there are two tabs: "Device Administration" and "Firmware Upgrade". A "Logout" button is located in the top right corner. On the left side, there is a blue navigation menu with the following items: System Status, Device Setup, Network Setup, Crestron Services Setup, OSD Setup, SNMP Setup, Device Services, Change Password, Firmware Upgrade (highlighted), Remote View Setup, Reset to Default, and Reboot System. The main content area is divided into two sections. The first section, "System Configuration", contains an "Export System configuration" button and an "Export" button. Below this is a file selection area with a "Choose File" button, the text "No file chosen", and an "Import" button. The second section, "Firmware Upgrade", contains a table with the following data:

Firmware Version	1.5.0.3
Release Date	20170417

Below the table, there is a warning message: "Please ensure that no users are connected before beginning the upgrade." Underneath the warning is a file selection area with a "Choose File" button, the text "No file chosen", and an "Upgrade" button.

At the bottom of the page, there is a copyright notice: "Copyright © 2017. All Rights Reserved".

Device settings can be imported from another device or exported to a file for use on another device.

***Export and Import System Configuration Settings***

Click **Export** to export the system configuration file.

Perform the following to import a system configuration file:

1. Click **Choose File** to select a file to import. The file has the .conf extension.
2. Click **Import** to import the configuration file and change the AM-100's settings.

***Upgrade Firmware***

Perform the following to update the AM-100's firmware:

1. Click **Choose File** to select the desired firmware file. The file has the .img extension.
2. Click **Upgrade** to update the AM-100's firmware.

**NOTE:** Firmware upgrades may take up to 30 minutes.

**NOTE:** Ensure that all users are disconnected from the AM-100 before upgrading the firmware.

**NOTE:** Use the AirMedia Firmware Update Utility (which is available for download from [www.crestron.com/airmedia](http://www.crestron.com/airmedia)) to update multiple AM-100s across an enterprise.

## Remote View Setup

Click **Remote View Setup** to configure remote view operations.

### *Device Administration Menu Showing the Remote View Setup Screen*

The screenshot displays the Crestron AirMedia Device Administration interface. At the top, the Crestron and AirMedia logos are visible. Below the logos, there are navigation tabs for "Device Administration" and "Remote View Setup", along with a "Logout" button. A left-hand navigation menu lists various system settings, with "Remote View Setup" highlighted. The main content area is divided into three sections:

- Remote View Control:** Contains two radio button options: "Remote view always active" (unselected) and "User controls remote view setting" (selected).
- Access Password Control:** Contains two radio button options: "Disabled" (selected) and "Use the same password as 'Code'" (unselected).
- Auto Refresh Interval (second):** Contains a radio button for "Manual Refresh" (selected) and a list of numerical options (5, 10, 20, 30, 45, 60, 90) with corresponding user limits in parentheses. For example, "5" is associated with "\*recommended maximum concurrent users. (5)".

At the bottom right of the settings area, there are "Apply" and "Cancel" buttons. A footer at the bottom of the page reads "Copyright © 2017. All Rights Reserved".

### **Remote View Control**

The **Remote View Control** section specifies whether remote viewing is available to connected viewers when a presenter connects to the AM-100.

Select **Remote view always active** to automatically allow remote viewing when the presenter connects to the AM-100. Select **User**



**controls remote view setting** to require the presenter to allow remote viewing.

### ***Access Password Control***

The **Access Password Control** section allows the code that is displayed on the screen to control access to the device when using remote view. Select **Disabled** or **Use the same password as “Code.”**

### ***Auto Refresh Interval***

The **Auto Refresh Interval** section specifies how often the presented content should be refreshed. Using the recommended maximum amount of concurrent users shown, select a refresh interval (in seconds) from the list and click **Apply**. To cancel, click **Cancel**.

## **Reset to Default**

Click **Reset to Default** and then click **Apply** to reset the AM-100 to the factory settings.

### ***Device Administration Menu Showing the Reset to Default Screen***

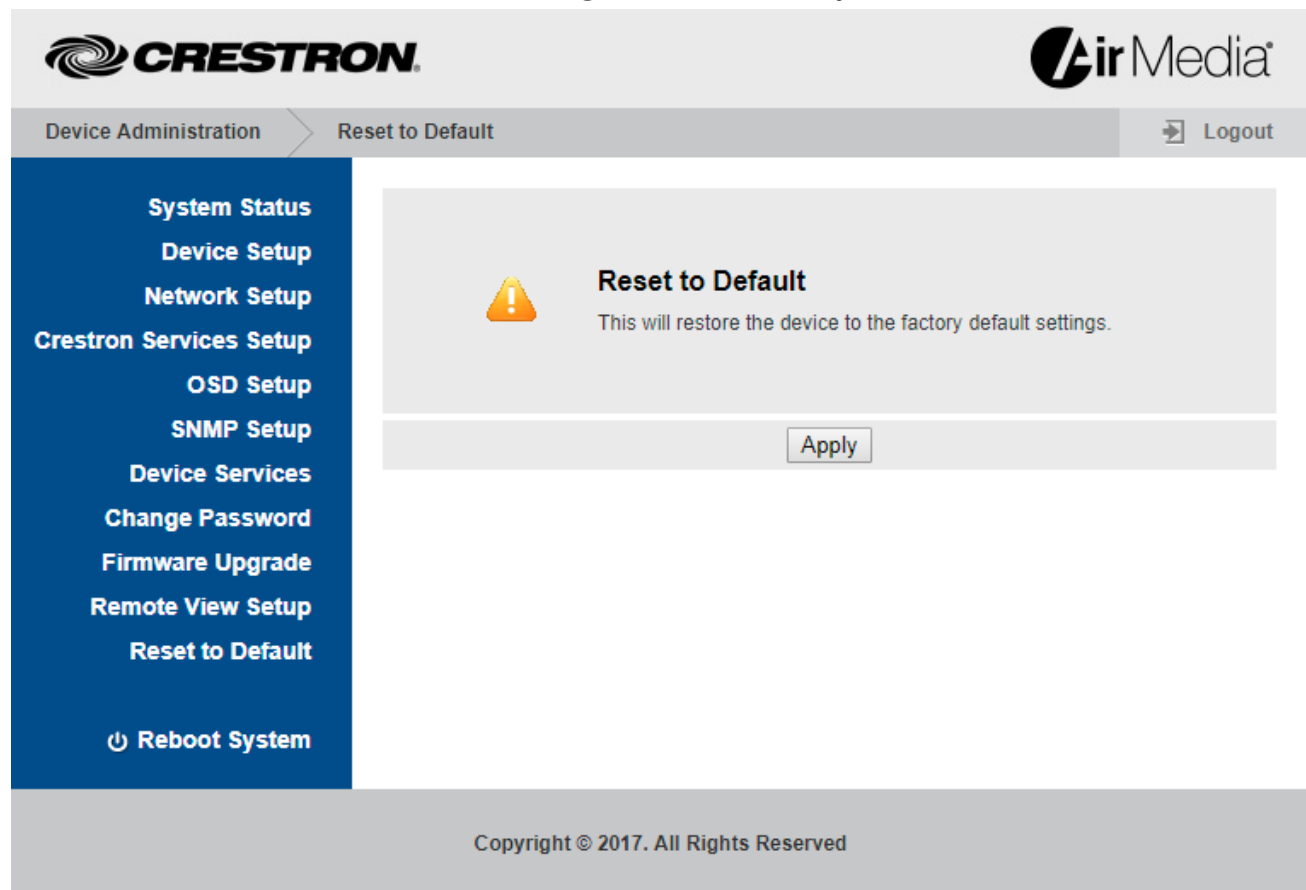

The screenshot displays the Crestron AirMedia web interface. At the top left is the Crestron logo, and at the top right is the AirMedia logo. Below the logos is a navigation bar with 'Device Administration' and 'Reset to Default' tabs, and a 'Logout' button. A left-hand menu lists various settings: System Status, Device Setup, Network Setup, Crestron Services Setup, OSD Setup, SNMP Setup, Device Services, Change Password, Firmware Upgrade, Remote View Setup, Reset to Default, and Reboot System. The main content area shows a warning icon (a yellow triangle with an exclamation mark) next to the heading 'Reset to Default'. Below the heading is the text: 'This will restore the device to the factory default settings.' At the bottom of this section is an 'Apply' button. The footer of the page contains the text: 'Copyright © 2017. All Rights Reserved'.

## **Reboot System**

Click **Reboot System** and click **Apply** to reboot the AM-100.

## Operation

The AM-100 uses a client application to share a PC or Mac® (hereafter referred to as “computer”) desktop. The computer should be able to access the AM-100 over the network.

**NOTE:** Crestron offers a stand-alone application for enterprise deployments. This application features additional connection methods and device management. For details, visit [present.crestron.com](http://present.crestron.com).

**NOTE:** Mobile devices can share content using the AirMedia for AM-100 app, which is available for iOS® and Android™ devices. Download the latest version from the App Store® app in iTunes® software or Google Play™ store.

1. Open a web browser on the computer, and navigate to the web address or the IP address that is displayed on the top left of the AM-100 welcome screen as shown on page 3. The download screen is displayed.

### Download Screen

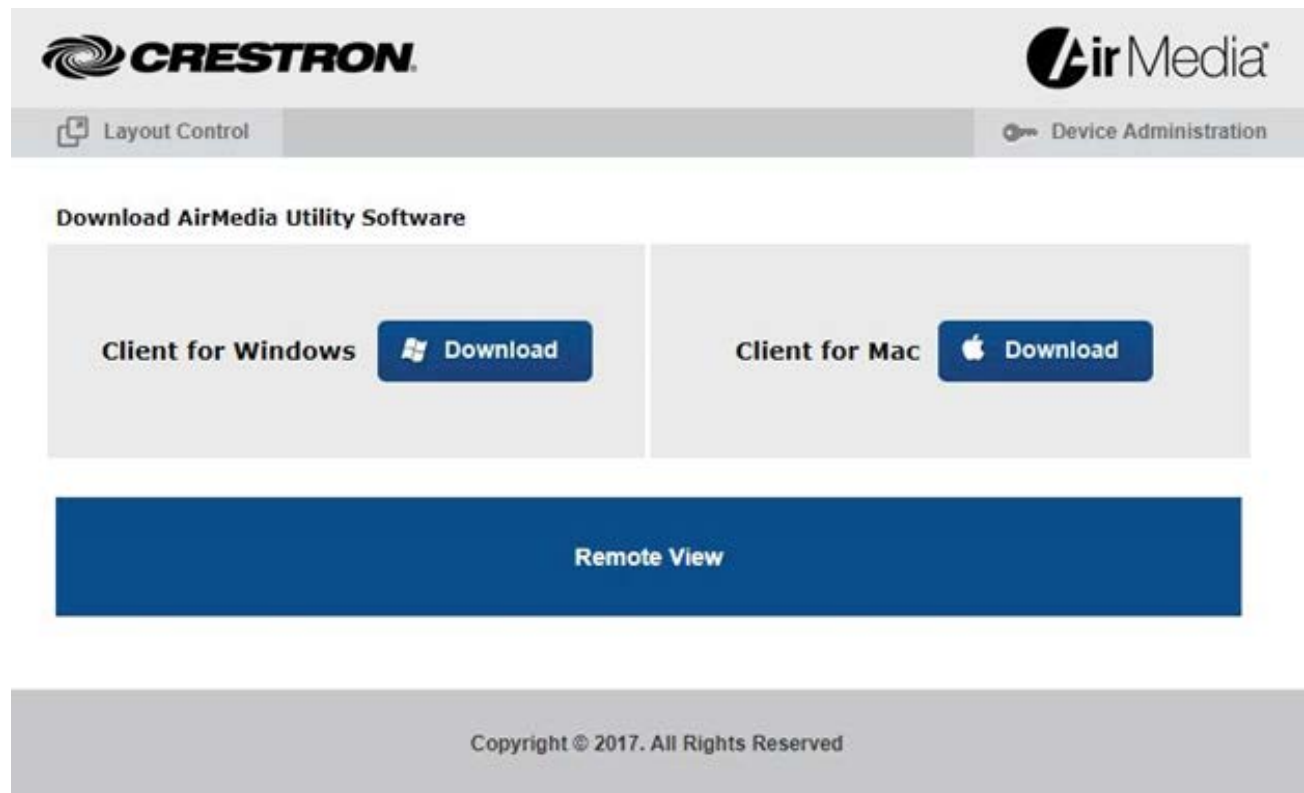

2. Click on the **Download** icon for the computer’s operating system and follow the instructions for installing the client software.

---

**NOTE:** When used on a Mac, the AirMedia application must be run from within the disk image file. Do not drag the application out of the disk image file.

---

## Run the AM-100 Client

1. Run the client software. The **Enter Code (Enter Passcode on Mac)** screen is displayed.

### *Enter Code Screen (Windows)*



### *Enter Passcode Screen (Mac)*

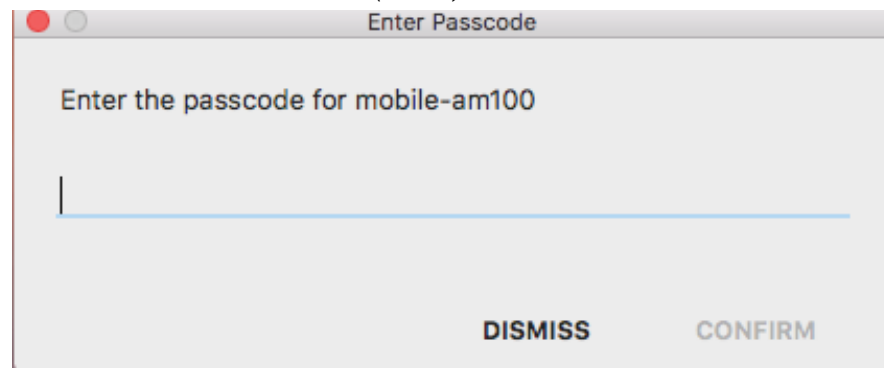

2. Enter the code displayed on the AM-100 welcome screen in the **Code** field and click **OK (CONFIRM on Mac)**. The client establishes a connection between the computer and the AM-100 while displaying the Crestron AirMedia controls on the computer.

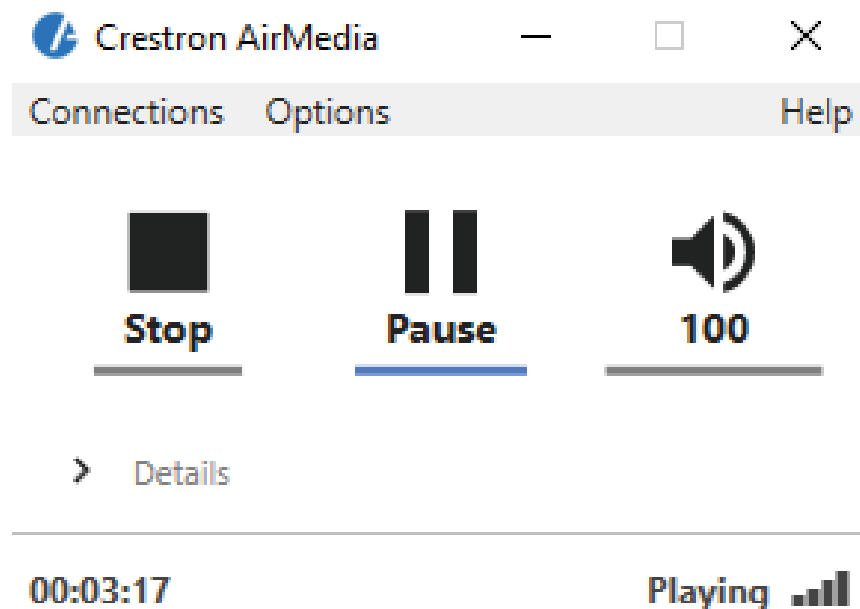
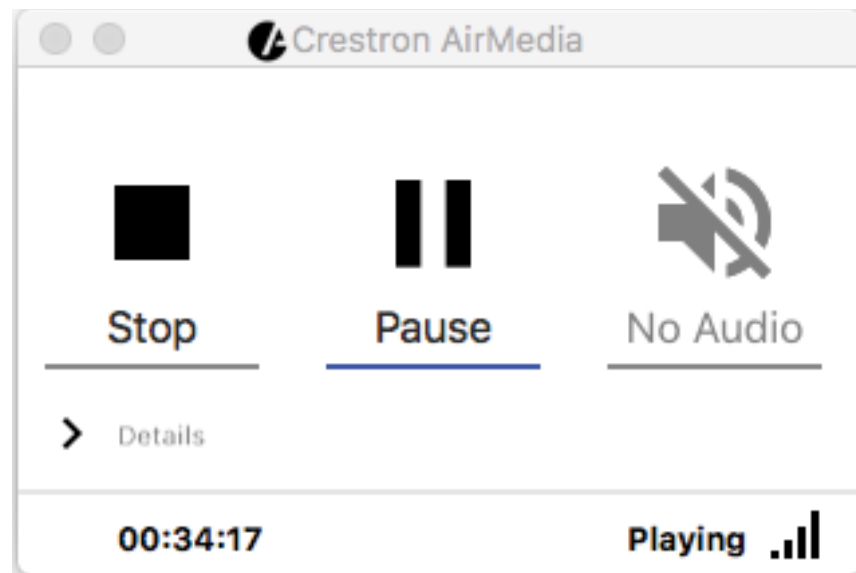









*Crestron AirMedia Controls (Windows)**Crestron AirMedia Controls (Mac)*

The contents of the computer screen are shown on the display connected to the AM-100.

**NOTE:** The application mutes the PC's local audio, since the audio is transmitted to the device and played through the display's speakers.

## Control the Presentation

Direct the presentation with the following controls:

- Click  to stop showing the computer's screen.
- Click  to start showing the computer's screen.
- Click  to freeze the computer's screen.
- Hover over  to show a volume slider control and drag the slider to raise or lower the volume.
- Click  to mute the audio output.
- Click  to unmute the audio output.
- Click  to close the client application and the connection between the computer and the AM-100. On a Mac, click  to close the client application and the connection between the computer and the AM-100.
- Click  to minimize the presentation control screen. On a Mac, click  to minimize the presentation control screen.

## Configure Basic Presentation Settings

Once a link between the computer and the AM-100 has been established, the AM-100 can be configured for custom operation.

Perform the following to configure the AM-100:

1. On the presentation control screen, click **Details**. The screen expands to show additional controls and information.

### *Presentation Control Screen Details (L - Windows, R - Mac)*

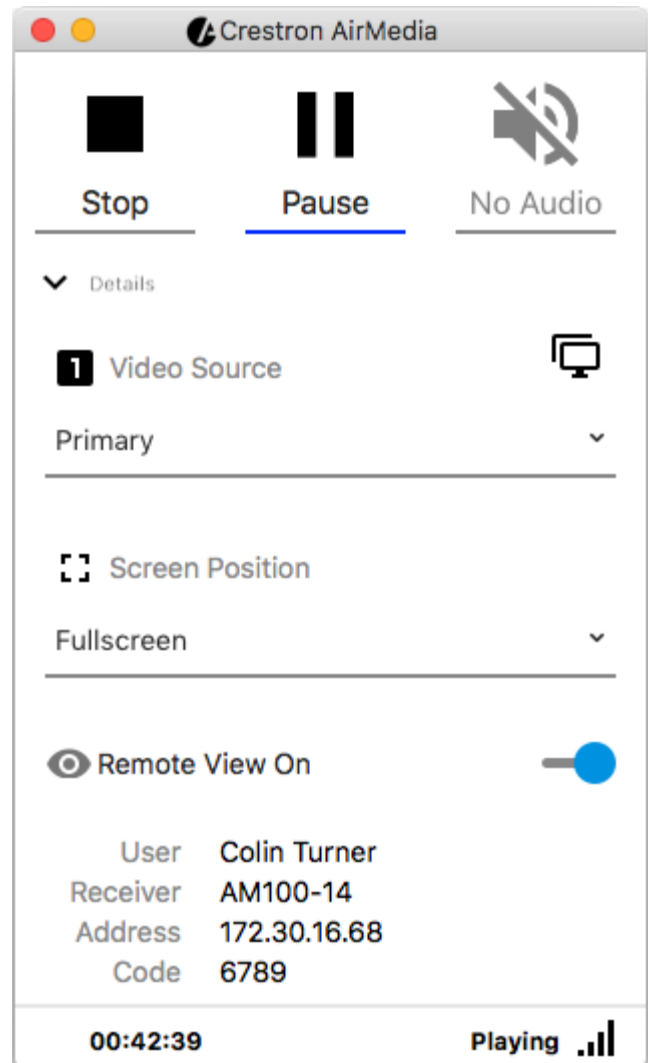
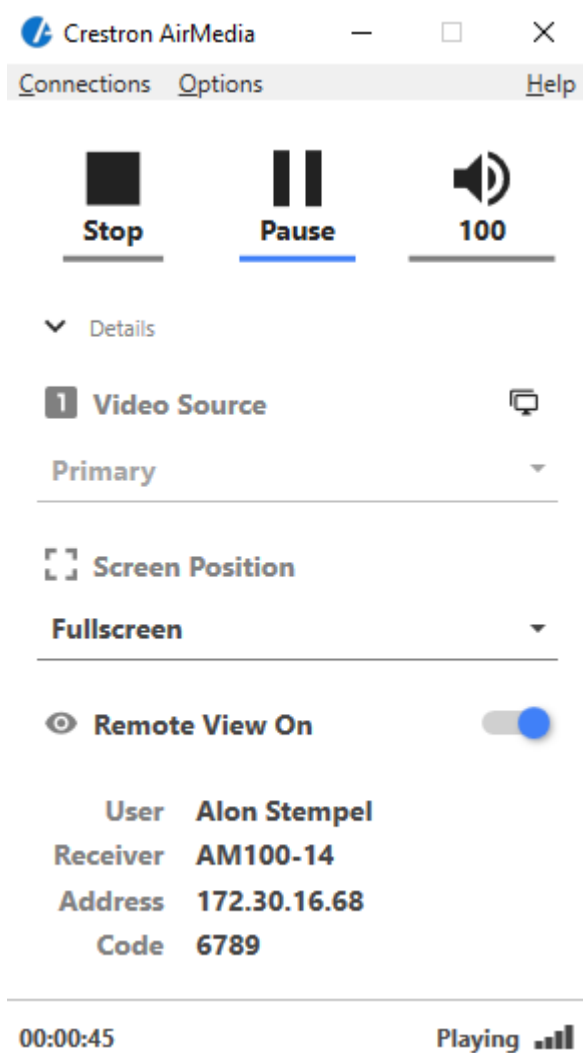

2. Configure the following options:
  - **Video Source (Windows® operating system only)** allows the user to share a secondary desktop. This is similar to the Extend mode in Windows for multiple displays. On a Mac, a secondary connected display can be shared.

- **Screen Position** sets the position of displayed content on a remote viewer's display. For details, refer to "Quad View" on page 29.
  - **Remote View** allows the device to serve images of the desktop to remote viewers via the built-in web server.
3. Configure the operation and the image quality settings:
    - a. Click **Options | Settings** (on a Mac, click **Crestron AirMedia | Preferences**). The **Settings** screen is displayed.

### Settings Screen (L - Windows, R - Mac)

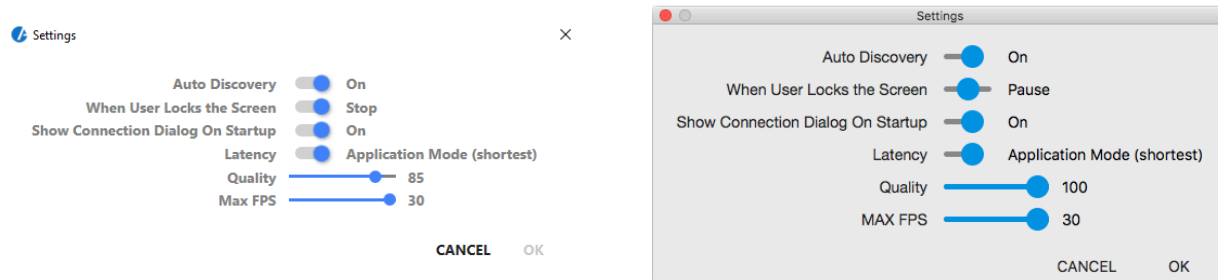

- b. Customize the settings.
  - **Auto Discovery** should be set to **On**.
  - **When User Locks the Screen** sets the behavior of the client software when the connected computer is locked. Choose from **Stop** (the client stops sharing), **Pause** (the client pauses sharing), or **Nothing** (nothing happens).
  - **Show Connection Dialog on Startup** selects whether connection information is displayed when the client starts.
  - **Latency** selects the amount of latency in transmitting the signal from the computer to the AM-101. Select **Application Mode (shortest)** for the least amount of latency or **Video Mode (PreBuffer)** for a longer amount of latency that is best suited for buffering shared video.
  - Set the **Quality** of the projected signal (0 to 100 percent).
  - Set the **Max FPS** (frames per second) refresh rate (1 to 30).
- c. Click **OK** to confirm the settings or click **Cancel** to cancel.



## Quad View

Up to four computers can simultaneously share their desktops with the AM-100. Shared desktops are arranged with each computer using one quarter of the projected image.

---

**NOTE:** If moderator controls are enabled, the screen position can be set by the moderator only. For details, refer to “Moderator Controls” on page 31.

**NOTE:** Although the AM-100 can support up to 32 connected computers for sharing, only four desktops can be displayed simultaneously.

---

Perform the following to share multiple desktops simultaneously:

1. Connect the computer to the AM-100 as described in “Run the AM-100 Client” on page 24.
2. Connect up to three other computers as described in “Run the AM-100 Client” on page 24.
3. Click **Details**. The screen expands to show additional controls and information
4. Select the position from the **Screen Position** drop-down list.

---

**NOTE:** If another computer is already sharing the selected position, the position is replaced by the newly shared desktop. Desktop playback ceases on the “booted” computer.

**NOTE:** If **Fullscreen** is chosen, any other shared desktops are replaced by the newly shared desktop. Desktop playback ceases on the “booted” computers.

---

## View a Presentation Remotely

If Remote View is enabled, users can view desktop images via the AM-100’s built-in web server. Perform the following to remotely view images:





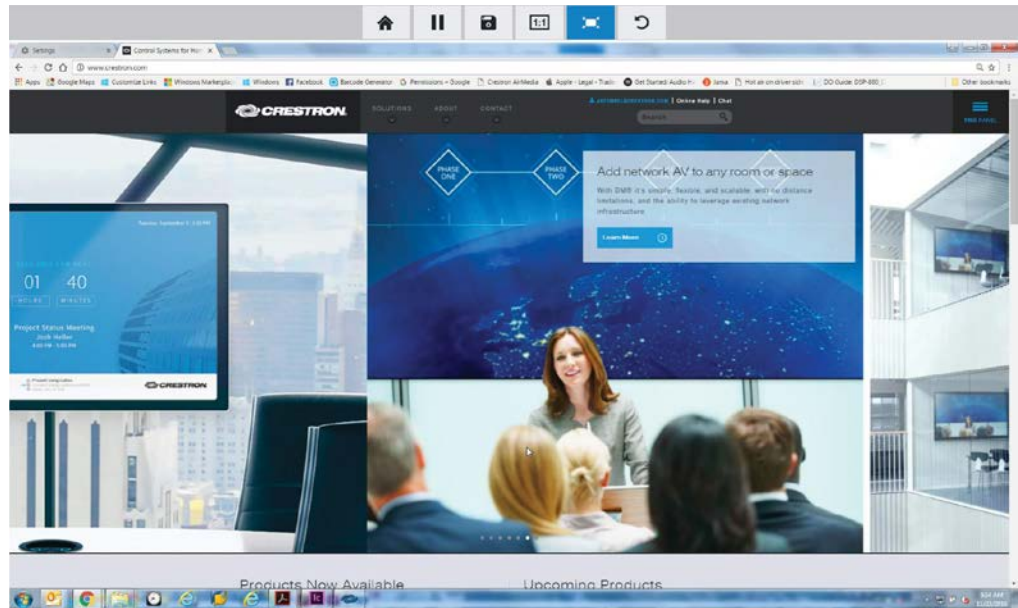

1. Open a web browser on a remote computer, and navigate to the web address or IP address supplied by the user or users that are sharing their desktops. The download screen as shown on page 23 is displayed.

2. Click **Remote View**. The shared desktop is displayed in the web browser as a web page.

### *Remote View Web Page*



3. Use the following buttons when viewing the AM-100's output in a web browser.

-  Exit remote viewing and return to the download screen.
-  Pause the currently displayed image.
-  Save the currently displayed image.
-  View the currently displayed image at actual size.
-  View the currently displayed image at full-screen size.
-  Refresh the image.

---

## Moderator Controls

Moderator controls are used to determine which users can present to the display device and where their presented content is located on the display.

### Login

1. Open a web browser on a remote computer, and navigate to the web address or the IP address that is displayed on the top left of the AM-100 welcome screen. The download screen is displayed.

---

**NOTE:** By default, the AM-100 displays the IP address in parentheses to assist in the configuration of the device. The IP address can be hidden so that the end user sees only a friendly URL (i.e., <http://AirMedia-019647>). For details, refer to “OSD Setup” on page 13.

---

### Download Screen

The screenshot displays the AirMedia download interface. At the top left is the Crestron logo, and at the top right is the AirMedia logo. Below the logos are two navigation tabs: "Layout Control" (with a square icon) and "Device Administration" (with a key icon). The main content area is titled "Download AirMedia Utility Software" and contains two columns. The left column is labeled "Client for Windows" and features a blue "Download" button with the Windows logo. The right column is labeled "Client for Mac" and features a blue "Download" button with the Apple logo. Below these columns is a large blue button labeled "Remote View". At the bottom of the screen, a grey footer bar contains the text "Copyright © 2017. All Rights Reserved".

2. Click **Layout Control**. The moderator login screen is displayed.

### *Moderator Login Screen*

CRESTRON

AirMedia

HOME

User Name moderator

Password .....

Login

Copyright © 2017. All Rights Reserved

3. Enter the moderator password (the default password is “moderator”) and click **Login**. The **Layout Control** screen is displayed showing a list of connected presenters.



*Layout Control Screen*

**CRESTRON** **AirMedia**

Crestron AirMedia > Layout Control Logout

**Layout Control**

**Moderator**  
When checked, changes to the layout can only be made by this browser session.

Name	Play Control	IP Address
Alon Stempel	  	172.30.16.96

**Device Mirroring**

Name	Play Control	IP Address
------	--------------	------------

Copyright © 2017. All Rights Reserved

## Control the Display Layout

1. Click the **Moderator** check box to enable layout control.

---

**NOTE:** If **Moderator** is enabled, the play control can be changed only by the user who is logged in as the moderator.

---

2. Up to four connected users can share content on the display at a time. Select the display capability of each connected user. Use the following controls for each connected presenter.



Sets the selected presenter to display in full screen.



Sets the selected presenter to display in a specific quadrant of the display. Click on the quadrant where the presenter's content is to be displayed.



Disconnects the selected presenter from the display.

---

## Hardware Reset

In the event that the administration pages are disabled or the device is configured with a static IP address that is on a different subnet and the AM-100's configuration screens cannot be accessed, the AM-100 must be reset to the factory settings. Perform the following to restore the factory settings:

1. Turn the AM-100 upside down as shown in the following diagram.

### *Underside of the AM-100*

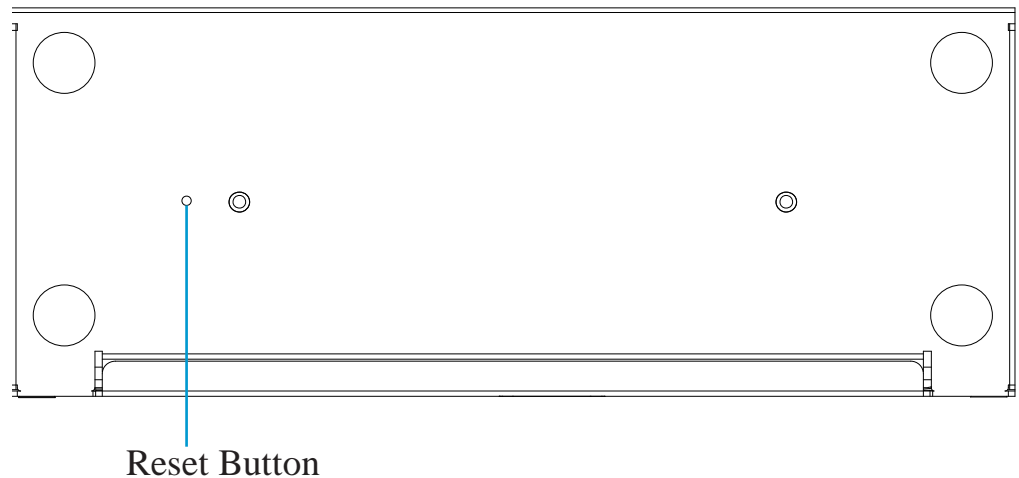

2. Unplug the AM-100.
3. Press and hold the reset button.
4. Plug in the AM-100 with the button still pressed.
5. Wait approximately 30 seconds or until the front LED turns green.
6. Release the reset button.
7. Unplug the AM-100.
8. Plug in the AM-100.

This page is intentionally left blank.



This page is intentionally left blank.



**Crestron Electronics, Inc.**  
15 Volvo Drive, Rockleigh, NJ 07647  
Tel: 888.CRESTRON  
Fax: 201.767.7576  
[www.crestron.com](http://www.crestron.com)



**Operations Guide – DOC. 7463F**  
**(2036012)**  
**12.17**

Specifications subject to  
change without notice.