

Crestron MMK-15L & WMKM-15L
Mud Mount Kits

Installation Guide



Contents

Mud Mount Kits: MMK-15L & WMKM-15L	1
Description.....	1
Setup.....	2
Supplied Hardware.....	2
Installation.....	4
Resources.....	12
Industry Compliance.....	12
Reference Documents.....	12
Further Inquiries.....	12
Future Updates.....	12
Return and Warranty Policies.....	13
Merchandise Returns / Repair Service.....	13
CRESTRON Limited Warranty.....	13

All brand names, product names and trademarks are the property of their respective owners.
©2008 Crestron Electronics, Inc.

Mud Mount Kits: MMK-15L & WMKM-15L

Description

Mud Mount Kits are the preferred mounting option for the Crestron Isys[®] TPS-15L and TPS-15G-L series of wall mounted touchpanels as well as the Isys i/O[™] TPMC-15-QM-L and TPMC-15-CH-L series of wall mounted touchpanels when the cutout made in the drywall for touchpanel installation is too large. These kits provide support for additional plastering that can be applied to hide large irregularities in the touchpanel cutout.

NOTE: If mounting into a material other than drywall (for example, wood lectern, concrete or rock) use the cutout template, available in the post-construction kit WMKM-15L. For concrete and rock mounting material, allow for proper ventilation before mounting the touchpanel.

There are two Mud Mount Kits. The MMK-15L is a pre-construction accessory. Pre-construction refers to framed walls prior to hanging drywall. This accessory must be used with either the Pre-Construction Mount Kit (PMK-15L) or Wall Mount Back Box Kit (BB-15L).

The WMKM-15L is a post-construction kit. Post-construction refers to framed walls with drywall hung. This accessory is designed with a mounting plate so that it can be placed anywhere on a wall without the support of a stud.

NOTE: If necessary, consult the latest revision of the TPS-12L/15L/17L Operations Guide (Doc. 6355), the TPS-12G/15G-L Operations Guide (Doc. 6356), or the TPMC-15/17-L Series Operations Guide (Doc. 6354) for a complete list of mounting options. These documents are available from the Crestron website (www.crestron.com/manuals).

Setup

Supplied Hardware

The MMK-15L consists of three parts. These parts produce an assembly that attaches to the BB-15L or PMK-15L. The WMKM-15L consists of five parts, three of which make up the MMK-15L, as well as a mounting plate and a cutout template set.

The mounting plate provides the necessary support for post-construction applications. Two overlay cutout templates (4007386) are supplied. One is in the shape of the required opening; the other is similar to a frame, with the inner area of the frame the shape of the required opening. (Refer to the illustration on pages 3.) Separate the wall cutout templates along the perforated lines to create the two templates. Use the template that is most convenient.

Supplied Hardware for the MMK-15L and WMKM-15L

DESCRIPTION	PART NUMBER	QUANTITY
Metal, Plate, Mud Ring	2013005	1
Metal Plate, Adjustment	2004825	2
Hardware, Metal, U-Type Fasteners	2004121	4
Metal, Plate, Mounting (WMKM-15L only)	2012920	1
Overlay, Template, Wall Cutout (WMKM-15L only)	4007386	1

The dimensions of the MMK-15L/WMKM-15L are shown below and on the next page.

Dimensional Drawing – Mud Ring Plate

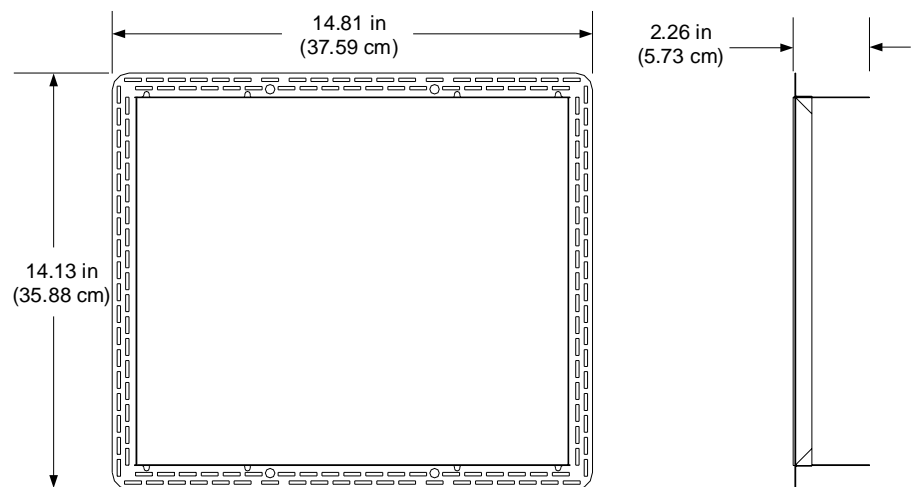

Dimensional Drawing – Adjustment Plate

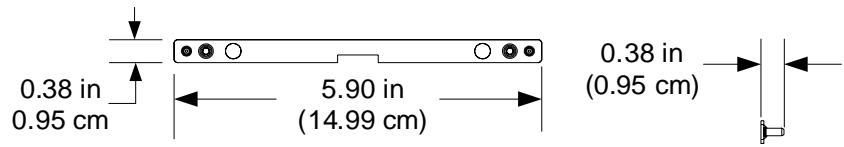

Dimensional Drawing – Mounting Plate

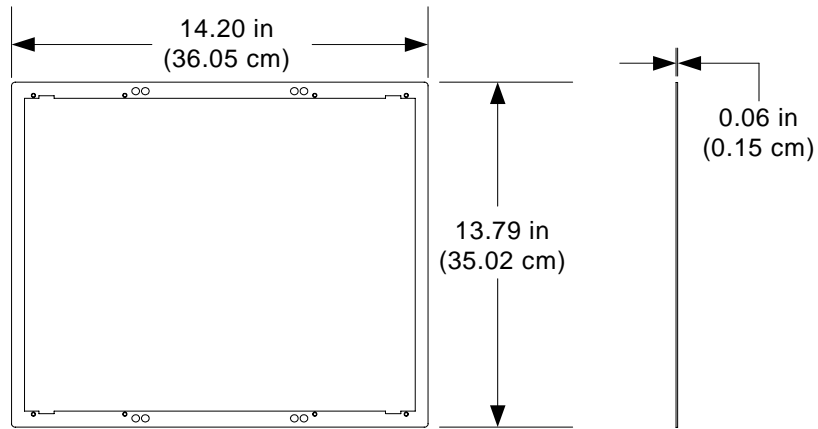

Drywall Cutout Template and Dimensions (supplied with WMKM-15L only)

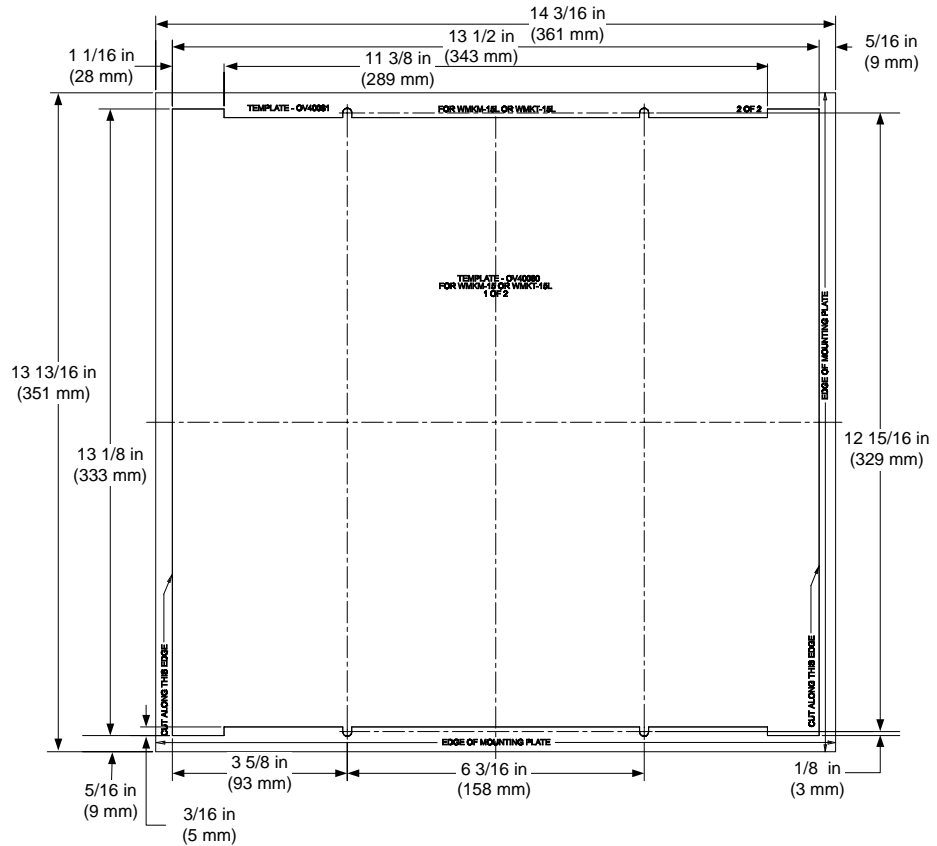

Installation

This section provides an installation procedure for each Mud Mount Kit. The “MMK-15L Procedure” starts below and the “WMKM-15L Procedure” starts on page 7. Be sure to review each procedure before starting.

MMK-15L Procedure

This section provides the necessary steps for the assembly of the MMK-15L with either the BB-15L or PKM-15L. It is assumed that the BB-15L or PKM-15L has been secured to the stud according to the instructions in the latest revisions of their Installation Guides (Doc. 6362 and Doc. 6363 respectively). It is also assumed that drywall is in place and a cutout is made in the drywall along the inside of the mounting plate for touchpanel installation.

Complete the steps in the order provided. The only tools or materials required and not supplied are four standard drywall screws, #2 Phillips screwdriver, a level and tools/material to apply drywall joint compound.

CAUTION: Allow an air gap of at least 12 inches (30.48 cm) in the wall cavity above and below the touchpanel for heat dissipation.

NOTE: The illustrations in this procedure show the installation of the MMK-15L with the PMK-15L. Even though the illustrations only show the PMK-15L, they are identical for the BB-15L.

1. Pass an adjustment plate through the opening and align its two center holes with the top two pins on the PMK-15L (or BB-15L). Verify that the pins on the adjustment plate are not between (facing) the adjustment plate and the PMK-15L (or BB-15L). Refer to the illustration on the following page for visual guidance.

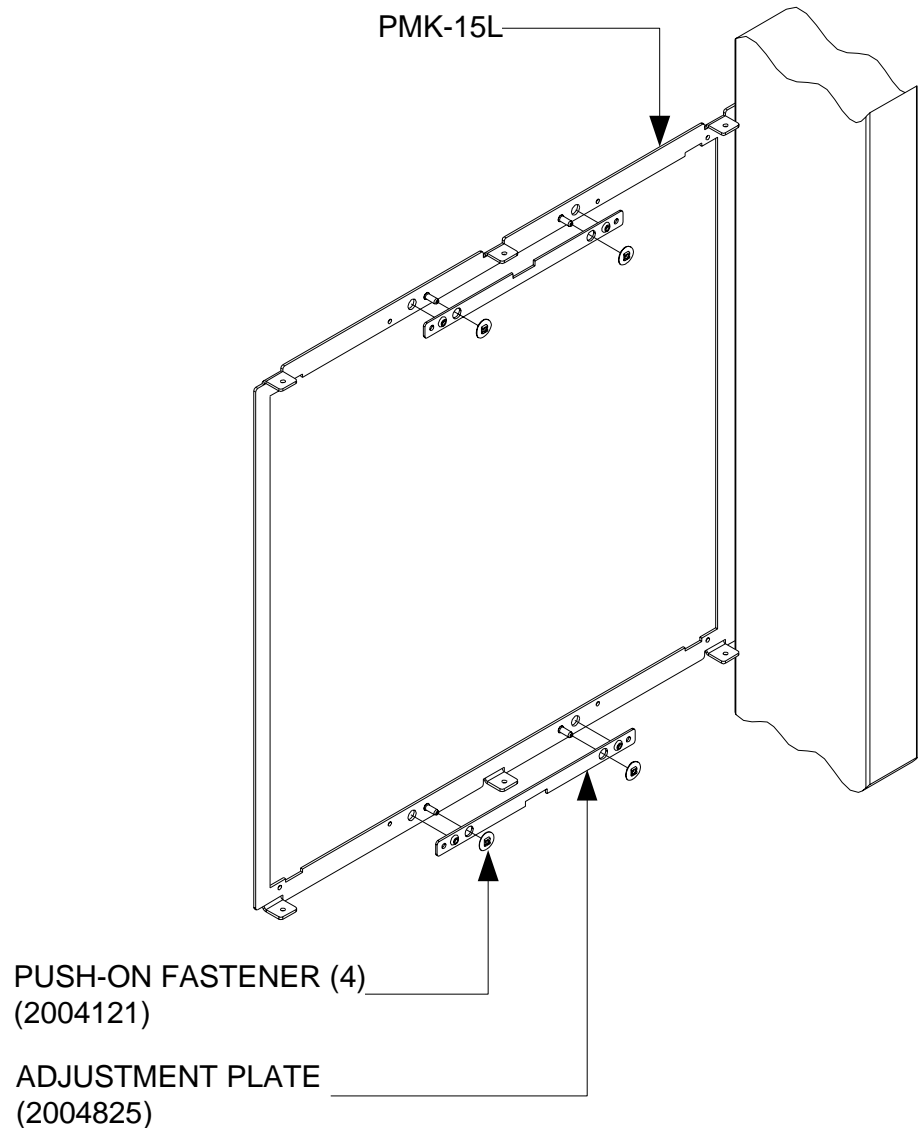
Secure Adjustment Plates to PMK-15L (or BB-15L)

2. Slide a push-on fastener over each pin of the PMK-15L (or BB-15L) to loosely secure the adjustment plate and the mounting plate. Do not push the push-on fasteners all the way down onto the pins. Slide them on enough to keep the adjustment plate and mounting plate as one adjustment/mounting plate assembly.
3. Use the second adjustment plate and repeat steps 1 and 2 using the lower two PMK-15L (or BB-15L) pins.

NOTE: When installing into the PMK-15L, verify that the 18 AWG bus wire securing the cables for the touchpanel remains attached.

4. Insert the symmetrical mud ring plate into the opening, as shown in the illustration on the following page.

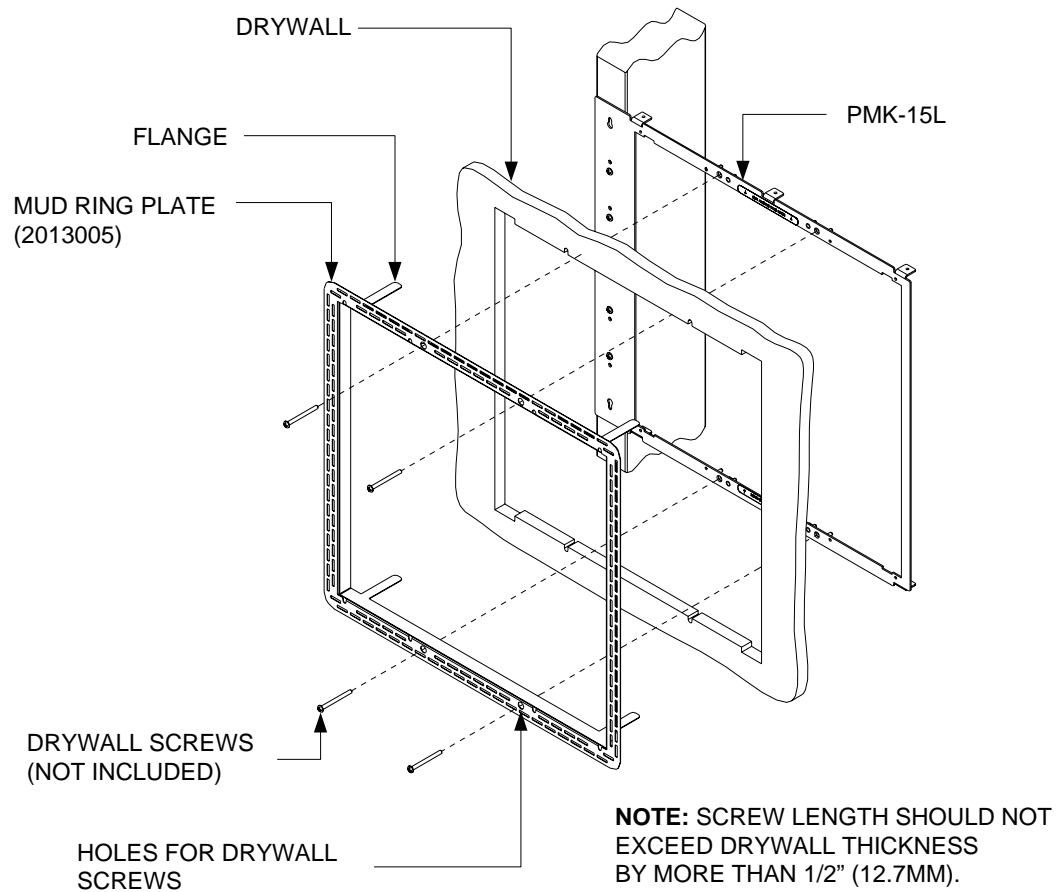
Insert and Secure Mud Ring Plate into PMK-15L (or BB-15L)

5. When the mud ring plate is in position, bend the top two flanges of the plate upward and the bottom two flanges downward.
 - If mounting into the PMK-15L, bend the flanges approximately 90 degrees.
 - If mounting into the BB-15L, bend the flanges back as far as they can go.
6. Use four standard drywall screws (length should not exceed drywall thickness by more than 1/2 inch) to secure the mud ring plate to the rest of the assembly. The screws pass through the clearance holes in the PMK-15L (or BB-15L) and are secured in the extruded holes of the adjustment plates.
7. Verify that the mud ring plate is level.

NOTE: Do not overtighten screws. Doing so may over-dimple or rip the mud ring plate.

8. Use a #2 Phillips screwdriver and tighten the drywall screws by hand so that they slightly dimple into the holes in the mud ring plate.
9. Apply drywall joint compound as needed to finish the cutout. Avoid covering the eight tapped mounting holes.

10. Run the necessary cables for the touchpanel and secure them behind the drywall.
11. When dry, the touchpanel can be installed using the eight tapped holes in the PMK-15L (or BB-15L). Refer to the latest revision of the TPS-12L/15L/17L Operations Guide (Doc. 6355), the TPS-12G/15G-L Operations Guide (Doc. 6356), or the TPMC-15/17-L Series Operations Guide (Doc. 6354) for installation instructions. Refer also to the comprehensive illustration as seen below.

TPS-15L Mounting Using MMK-15L – Exploded View

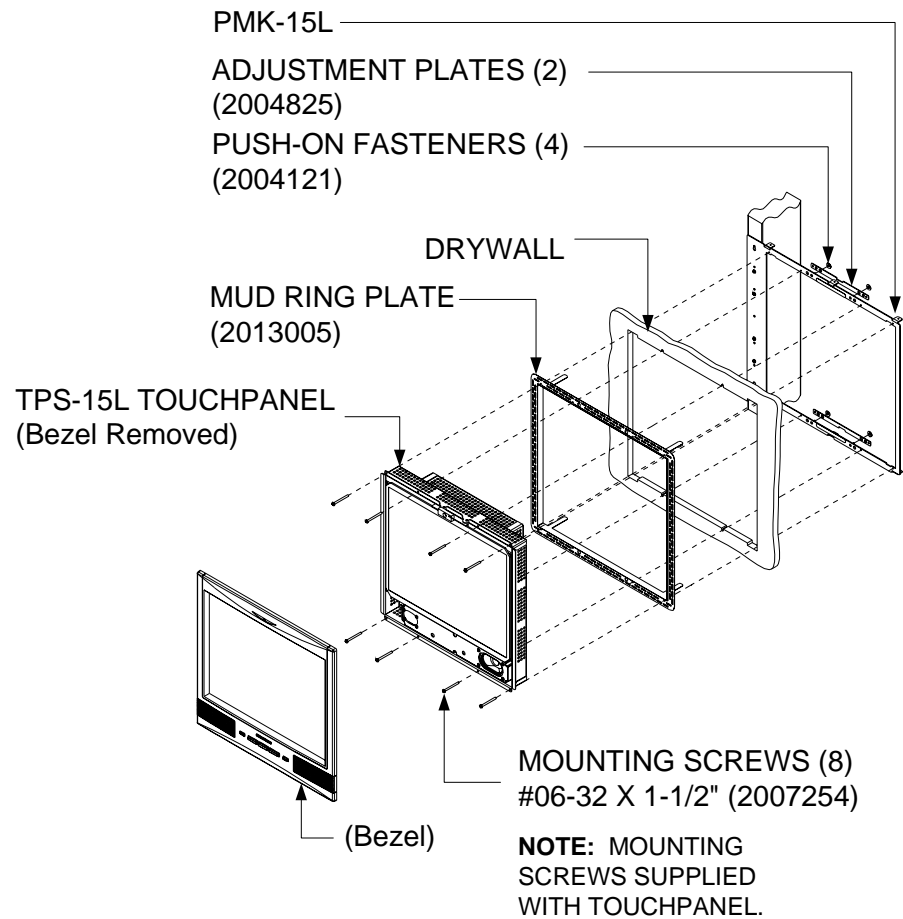

WMKM-15L Procedure

This section provides the necessary steps for the assembly and installation of the WMKM-15L into a wall. Review the procedure and complete the steps in the order provided. The only tools or materials required and not supplied are a drywall saw or equivalent, a level, four standard drywall screws, #2 Phillips screwdriver and tools/material to apply drywall joint compound.

CAUTION: Allow an air gap of at least 12 inches (30.48 cm) in the wall cavity above and below the touchpanel for heat dissipation.

1. Insert the two pins on one adjustment plate into the top two outer holes on the mounting plate, as shown in the illustration on the following page.

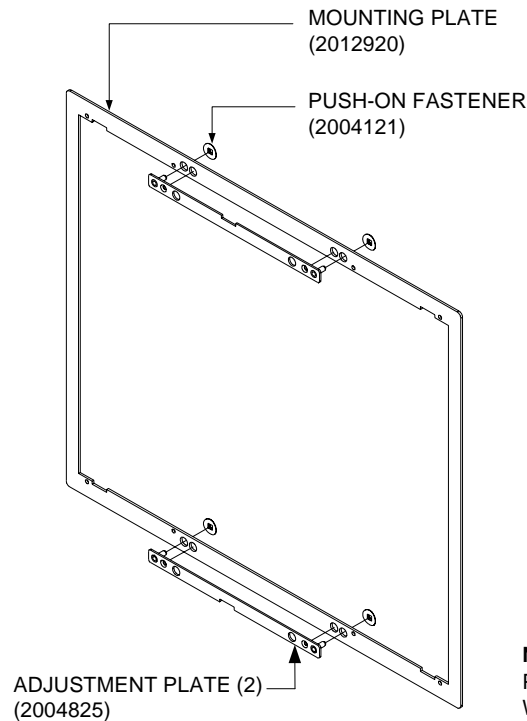
Create the Adjustment/Mounting Plate Assembly

NOTE: DO NOT PUSH THE PUSH-ON FASTENERS ALL THE WAY DOWN ONTO THE PINS.

2. Slide a push-on fastener over each pin on the adjustment plate to loosely secure the adjustment plate and the mounting plate. Do not push the push-on fasteners all the way down onto the pins. Slide them on enough to keep the adjustment plate and mounting plate as one adjustment/mounting plate assembly.
3. Use the second adjustment plate and repeat steps 1 and 2 using the lower two pins of the mounting plate.
4. Locate an area on the wall that is free of miscellaneous wiring and studs.
5. Make a small hole near the middle of the designated site; verify that the location is suitable.

NOTE: Make the cutout as clean and level as possible. The mounting plate allows for only minor leveling adjustments.

6. Use the drywall saw or equivalent and the provided drywall cutout template to produce an accurate and level cutout in the drywall.
7. Insert the symmetrical mud ring plate into the opening, as shown in the illustration on the following page.

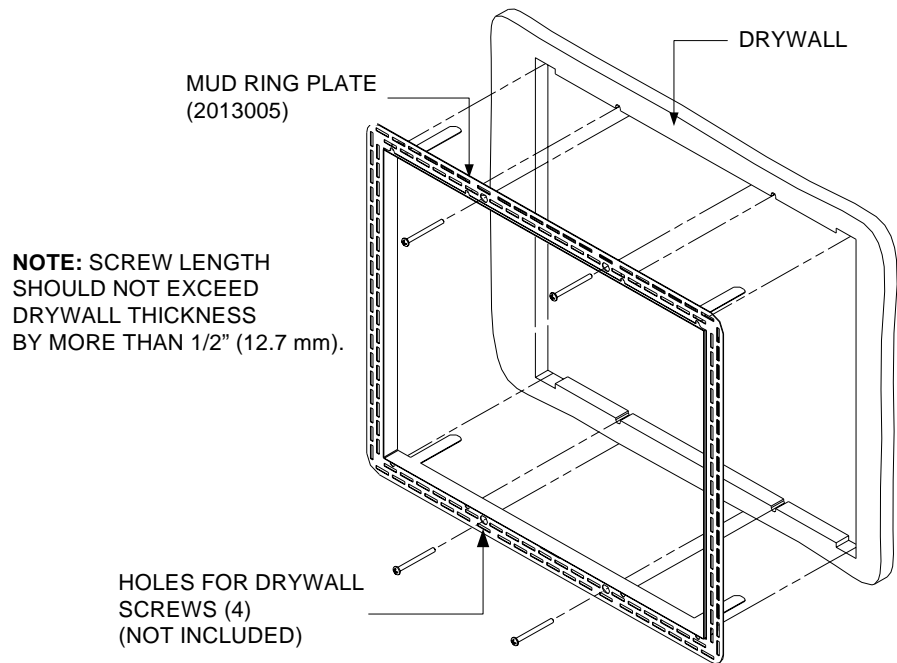
Insert Mud Ring Plate into Opening

8. Carefully pass the adjustment/mounting plate assembly through the opening and rest the assembly against the interior surface of the drywall. Verify that the adjustment plates are between the mounting plate and the drywall.
9. When the adjustment/mounting plate assembly is in position, bend the top two flanges of the mud ring upward (approximately 90 degrees) and the bottom two flanges downward (approximately 90 degrees). Refer to the illustration on the following page.

NOTE: Adjustment/mounting plate assembly will have a slight play; this is normal. It allows for minor adjustments to the entire assembly during installation.

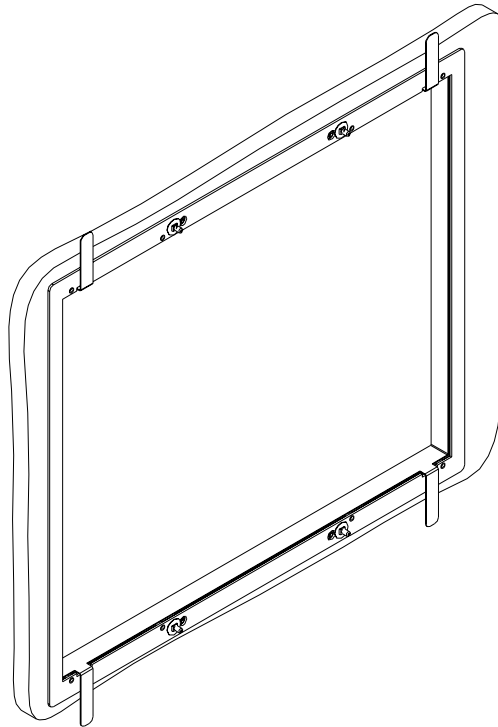
Bend Flanges

10. Use four standard drywall screws (length should not exceed drywall thickness by more than 1/2 inch) to secure the plate to the adjustment/mounting plate assembly. The screws pass through the clearance holes in the mud ring plate and are secured in the extruded holes of the adjustment plates.
11. Verify that the plate is level before tightening.

NOTE: Do not over tighten screws. Doing so may damage the plate.

12. Use a #2 Phillips screwdriver and tighten the drywall screws by hand so that they slightly dimple into the holes in the mud ring plate.
13. Run the necessary cables for the touchpanel and secure them behind the drywall.
14. Apply drywall joint compound as needed to finish the cutout. Avoid covering the eight tapped mounting holes.
15. When the joint compound is dry, the touchpanel can be installed using the eight tapped holes in the mounting plate. Refer to the latest revision of the TPS-12L/15L/17L Operations Guide (Doc. 6355), the TPS-12G/15G-L Operations Guide (Doc. 6356), or the TPMC-15/17-L Series Operations Guide (Doc. 6354) for details. Refer also to the comprehensive illustration on the following page.

TPS-15L Mounting Using WMKM-15L – Exploded View

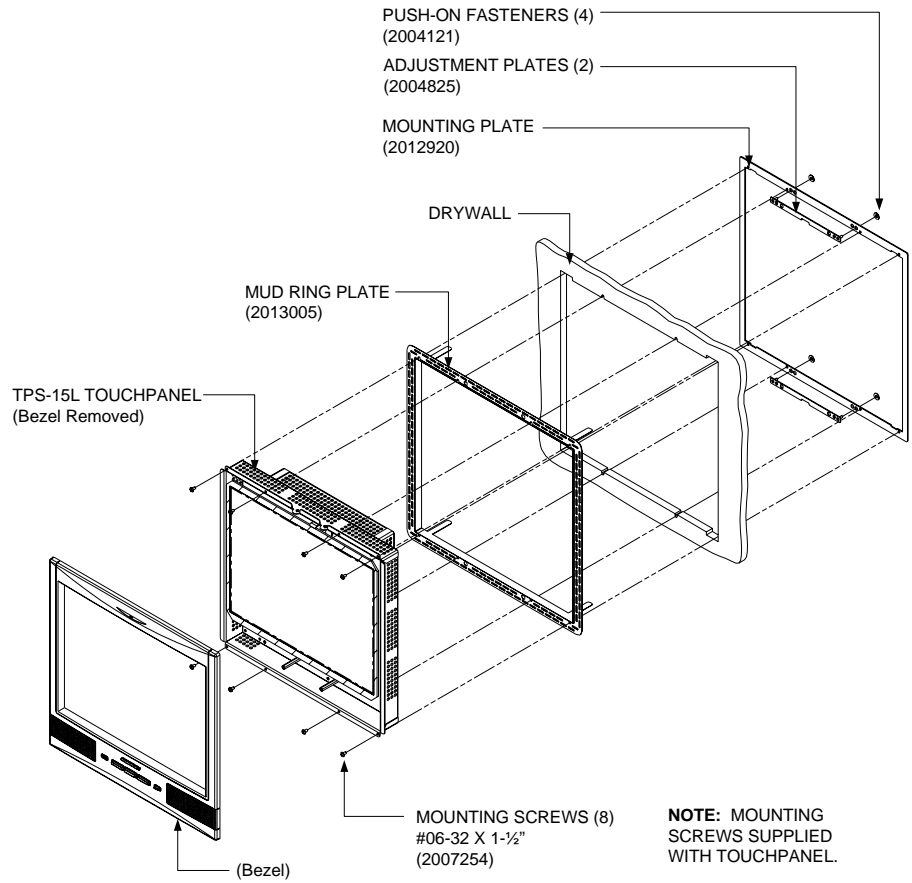

Resources

Industry Compliance

As of the date of manufacture, the MMK-15L and WMKM-15L have been tested and found to comply with specifications for CE marking.



Reference Documents

The latest version of all documents mentioned within the guide can be obtained from the Crestron website (www.crestron.com/manuals). This link will provide a list of product manuals arranged in alphabetical order by model number.

List of Related Reference Documents

DOCUMENT TITLE
BB-15L Wall Mount Back Box
PMK-15L Pre-Construction Mounting Kit
TPMC-15/17-L Series Isys I/O™ Wall Mount Touchpanel Media Centers
TPS-12G/15G-QM-L Isys® G-Series Wall Mount Touchpanels
TPS-12L/15L/17L Isys® Wall Mount Touchpanels

Further Inquiries

If you cannot locate specific information or have questions after reviewing this guide, please take advantage of Crestron's award winning customer service team by calling Crestron at 1-888-CRESTRON [1-888-273-7876].

You can also log onto the online help section of the Crestron website (www.crestron.com/onlinehelp) to ask questions about Crestron products. First-time users will need to establish a user account to fully benefit from all available features.

Future Updates

As Crestron improves functions, adds new features and extends the capabilities of the MMK-15L or WMKM-15L, additional information may be made available as manual updates. These updates are solely electronic and serve as intermediary supplements prior to the release of a complete technical documentation revision.

Check the Crestron website periodically for manual update availability and its relevance. Updates are identified as an “Addendum” in the Download column.

Return and Warranty Policies

Merchandise Returns / Repair Service

1. No merchandise may be returned for credit, exchange or service without prior authorization from CRESTRON. To obtain warranty service for CRESTRON products, contact an authorized CRESTRON dealer. Only authorized CRESTRON dealers may contact the factory and request an RMA (Return Merchandise Authorization) number. Enclose a note specifying the nature of the problem, name and phone number of contact person, RMA number and return address.
2. Products may be returned for credit, exchange or service with a CRESTRON Return Merchandise Authorization (RMA) number. Authorized returns must be shipped freight prepaid to CRESTRON, 6 Volvo Drive, Rockleigh, N.J. or its authorized subsidiaries, with RMA number clearly marked on the outside of all cartons. Shipments arriving freight collect or without an RMA number shall be subject to refusal. CRESTRON reserves the right in its sole and absolute discretion to charge a 15% restocking fee plus shipping costs on any products returned with an RMA.
3. Return freight charges following repair of items under warranty shall be paid by CRESTRON, shipping by standard ground carrier. In the event repairs are found to be non-warranty, return freight costs shall be paid by the purchaser.

CRESTRON Limited Warranty

CRESTRON ELECTRONICS, Inc. warrants its products to be free from manufacturing defects in materials and workmanship under normal use for a period of three (3) years from the date of purchase from CRESTRON, with the following exceptions: disk drives and any other moving or rotating mechanical parts, pan/tilt heads and power supplies are covered for a period of one (1) year; touchscreen display and overlay components are covered for 90 days; batteries and incandescent lamps are not covered.

This warranty extends to products purchased directly from CRESTRON or an authorized CRESTRON dealer. Purchasers should inquire of the dealer regarding the nature and extent of the dealer's warranty, if any.

CRESTRON shall not be liable to honor the terms of this warranty if the product has been used in any application other than that for which it was intended or if it has been subjected to misuse, accidental damage, modification or improper installation procedures. Furthermore, this warranty does not cover any product that has had the serial number altered, defaced or removed.

This warranty shall be the sole and exclusive remedy to the original purchaser. In no event shall CRESTRON be liable for incidental or consequential damages of any kind (property or economic damages inclusive) arising from the sale or use of this equipment. CRESTRON is not liable for any claim made by a third party or made by the purchaser for a third party.

CRESTRON shall, at its option, repair or replace any product found defective, without charge for parts or labor. Repaired or replaced equipment and parts supplied under this warranty shall be covered only by the unexpired portion of the warranty.

Except as expressly set forth in this warranty, CRESTRON makes no other warranties, expressed or implied, nor authorizes any other party to offer any warranty, including any implied warranties of merchantability or fitness for a particular purpose. Any implied warranties that may be imposed by law are limited to the terms of this limited warranty. This warranty statement supersedes all previous warranties.

Trademark Information

All brand names, product names, and trademarks are the sole property of their respective owners. Windows is a registered trademark of Microsoft Corporation. Windows95/98/Me/XP/Vista and WindowsNT/2000 are trademarks of Microsoft Corporation.



Crestron Electronics, Inc.
15 Volvo Drive Rockleigh, NJ 07647
Tel: 888.CRESTRON
Fax: 201.767.7576
www.crestron.com

**Installation Guide – DOC. 6364A
(2013140)**

10.08

Specifications subject to
change without notice.