

Crestron **PMK-V24**  
Pre-Construction Mounting Kit  
for V24R-WALL-C and V24RL-C

---

Installation Guide



This document was prepared and written by the Technical Documentation department at:



### **Regulatory Compliance**

As of the date of manufacture, the PMK-V24 has been tested and found to comply with specifications for CE marking and standards per EMC and Radiocommunications Compliance Labelling.



The specific patents that cover Crestron products are listed at [www.crestronpatents.com](http://www.crestronpatents.com).

Crestron, the Crestron logo and V-Panel are either trademarks or registered trademarks of Crestron Electronics, Inc. in the United States and other countries. Other trademarks, registered trademarks and trade names may be used in this document to refer to either the entities claiming the marks and names or their products. Crestron disclaims any proprietary interest in the marks and names of others.

©2011 Crestron Electronics, Inc.

# Contents

## **Pre-Construction Mounting Kit for V24R-WALL-C and V24RL-C: PMK-V24 1**

Description.....	1
Setup.....	4
Supplied Hardware.....	4
Mounting.....	4
Touch Screen Installation.....	9
Resources.....	10
Reference Documents.....	10
Further Inquiries.....	10
Future Updates.....	10
Return and Warranty Policies.....	11
Merchandise Returns / Repair Service.....	11
Crestron Limited Warranty.....	11



# Pre-Construction Mounting Kit for V24R-WALL-C and V24RL-C: PMK-V24

---

## Description

The PMK-V24 mounting kit provides a simple solution for installing the Crestron® V24R-WALL-C V-Panel™ 24" Wall Mount HD Touch Screen Display. Designed for pre-construction applications, the PMK-V24 permits fastening to the studs of a framed wall prior to installation of drywall. A blank cover plate is included to provide a temporary cover for the opening during construction.

This is also the recommended mounting kit for installing a V24RL-C 24" Lectern Mount HD Touch Screen Display into a lectern or other furniture.

---

**NOTE:** For wall mount applications, this mounting kit requires a stud spacing of ~26 3/4" O.C. (~680 mm O.C.) and an inside width of at least 25 1/4" (640 mm) between studs.

---

The dimensions of the PMK-V24 are shown in the illustrations below and on the following page.

*PMK-V24 Overall Dimensions (Front and Side Views)*

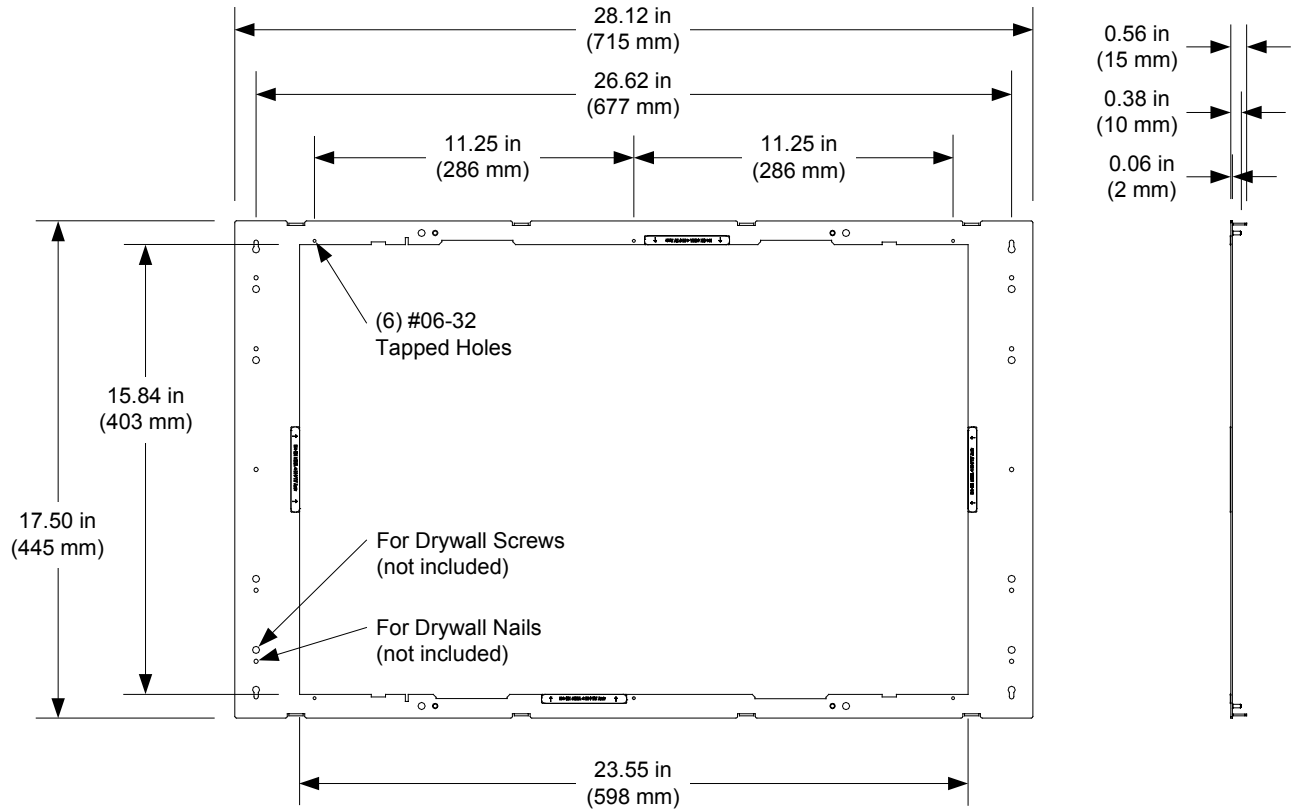

*PMK-V24 Overall Dimensions (Front View)*

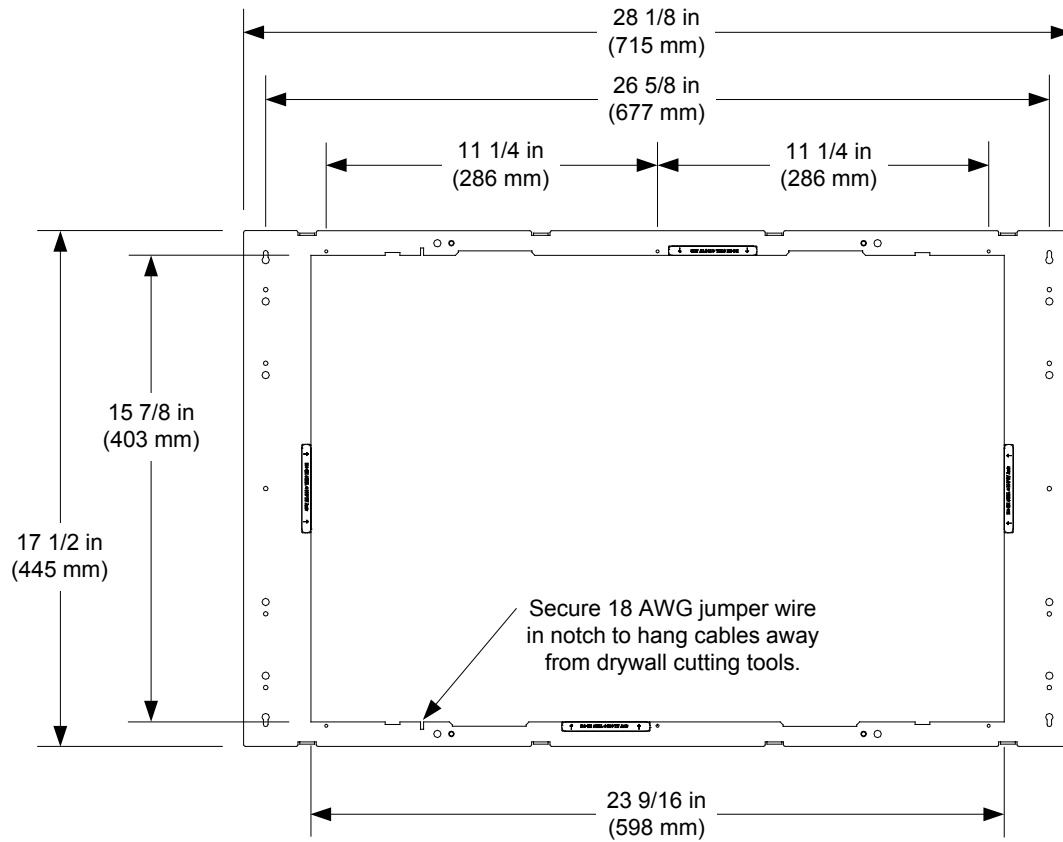

*PMK-V24 Overall Dimensions (Cover Plate)*

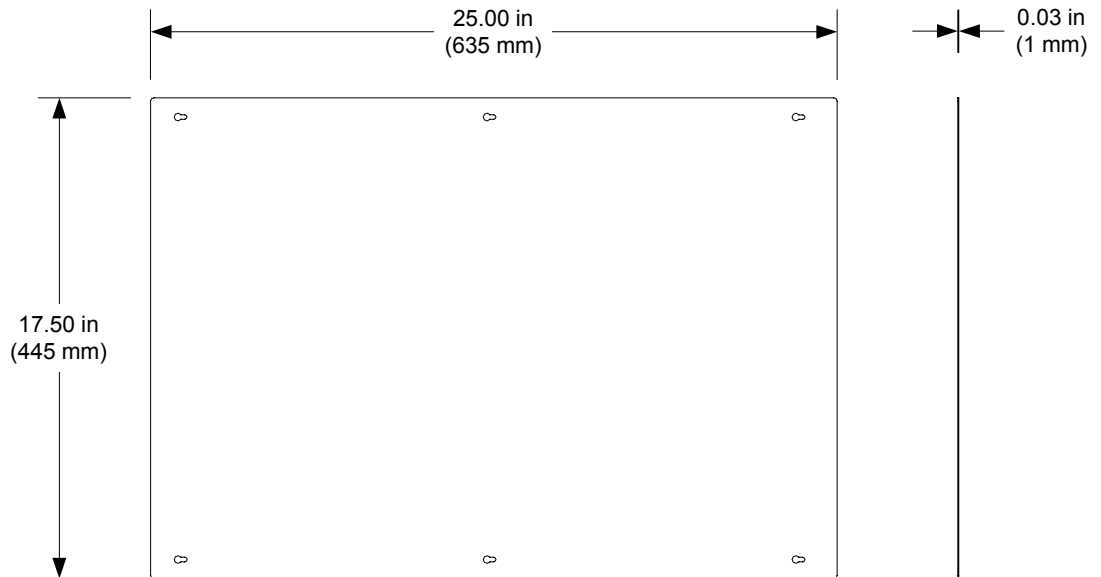

---

## Setup

### Supplied Hardware

The hardware supplied with the PMK-V24 is listed in the following table.

*Supplied Hardware for the PMK-V24*

DESCRIPTION	PART NUMBER	QUANTITY
Assembly, Pre-Construction Mount Kit, V24	4513693	1
Metal, Plate, Cover	2030243	1
Screw, #06-32 x 1-1/2", Pan, Phil	2007254	6
Wire, Jumper, 12", 18 AWG, Black	2007838	1

### Mounting

The PMK-V24 consists of a single metal plate, which fastens to the studs of a framed wall prior to hanging drywall. Installation requires custom framing. Standard drywall nails or screws to attach the PMK-V24 and appropriate framing materials not included.

The plate is designed to provide the necessary support for a single touch screen display. Confirm the PMK-V24 is level before applying drywall.



*Dimensions for Drywall Cutout*

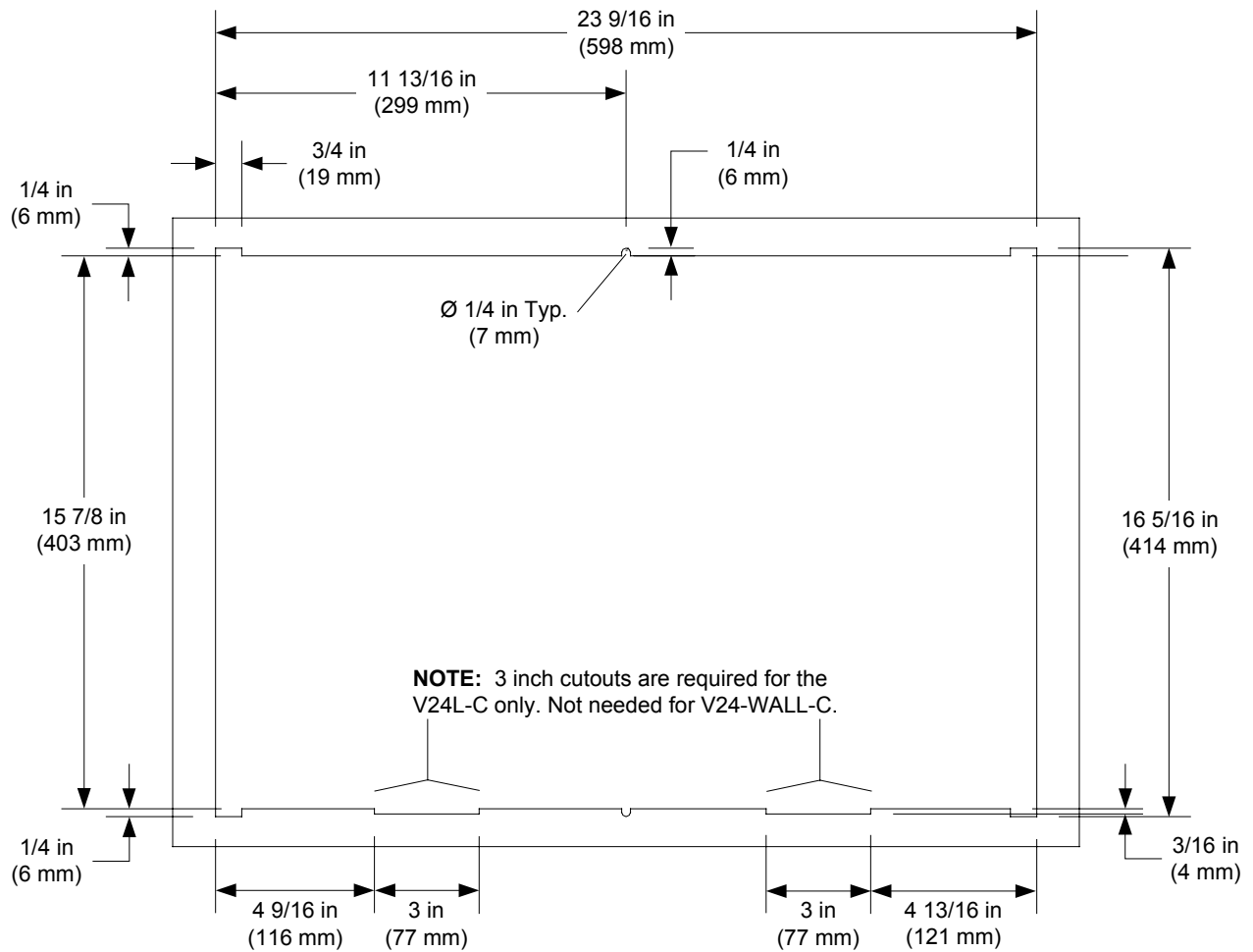

**Required Tools and Materials:**

- #2 Phillips tip screwdriver or hammer
- Level
- Standard drywall screws or nails (not included)

**CAUTION:** Allow an air gap of at least 24 inches (610 mm) in the wall cavity above and below the touch screen for heat dissipation.

**NOTE:** If your installation is not on wooden studs, be sure to consider the needs of your particular situation. For example, screw type may vary for steel studs, etc.

**NOTE:** To maintain optimum structural integrity, Crestron recommends installing header and footer studs around the BB-V24, observing the required air gap.

**NOTE:** The PMK-V24 requires a stud spacing of ~26 3/4" O.C. (680 mm O.C.) and an inside width of at least 25 1/4" (640 mm) between studs. Otherwise, the PMK-V24 will not fit.

**NOTE:** The PMK-V24 has been optimized for mounting in 5/8" (15 mm) drywall. You may use 1/2" – 1" (13 – 25 mm) without issue. Thinner or thicker drywall will cause issues with the installation.

Complete the following procedure (refer to the illustrations that follow) to mount the PMK-V24.

1. Frame the opening for the PMK-V24, as shown in the illustration below.

***Framing the PMK-V24***

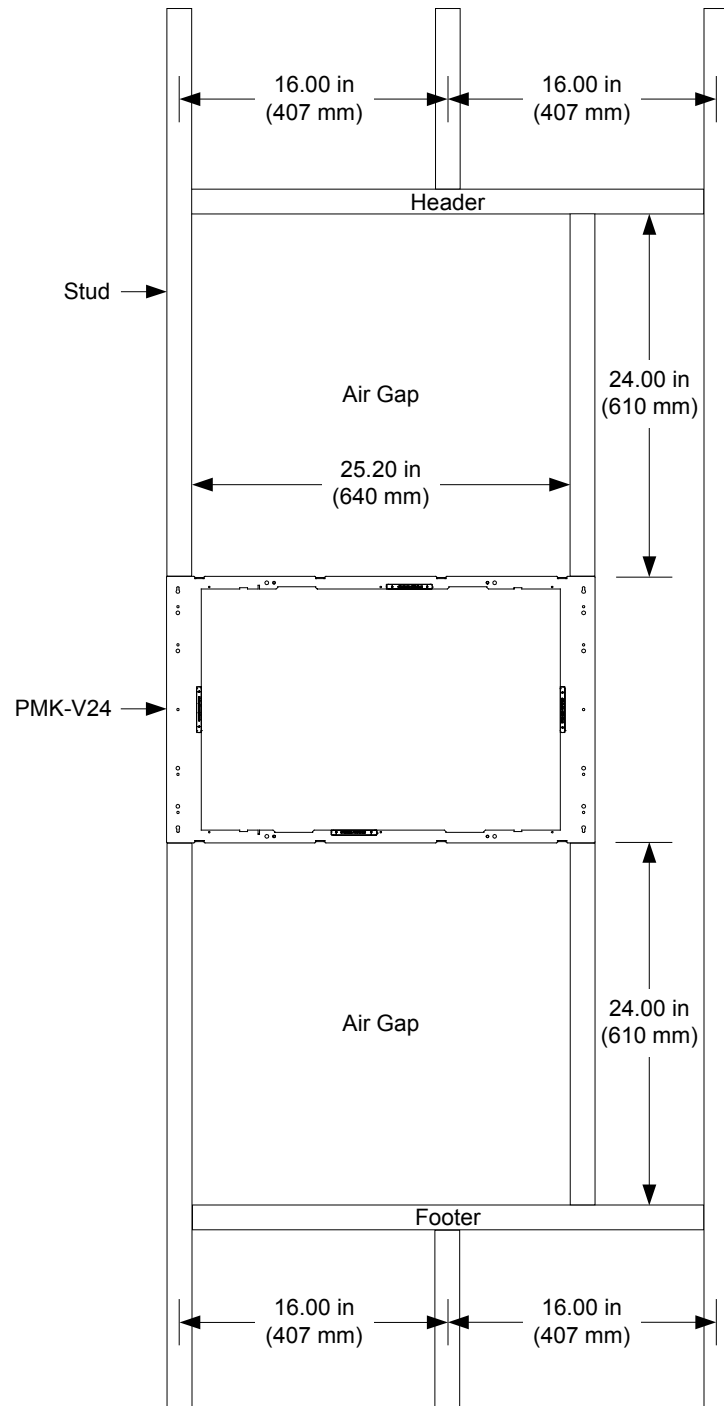

- Using the level, attach the PMK-V24 to both the left and right studs using drywall screws or nails (not included). Make sure the mounting kit is attached close to the center of the studs. Refer to the following illustration.

**Mounting the PMK-V24**

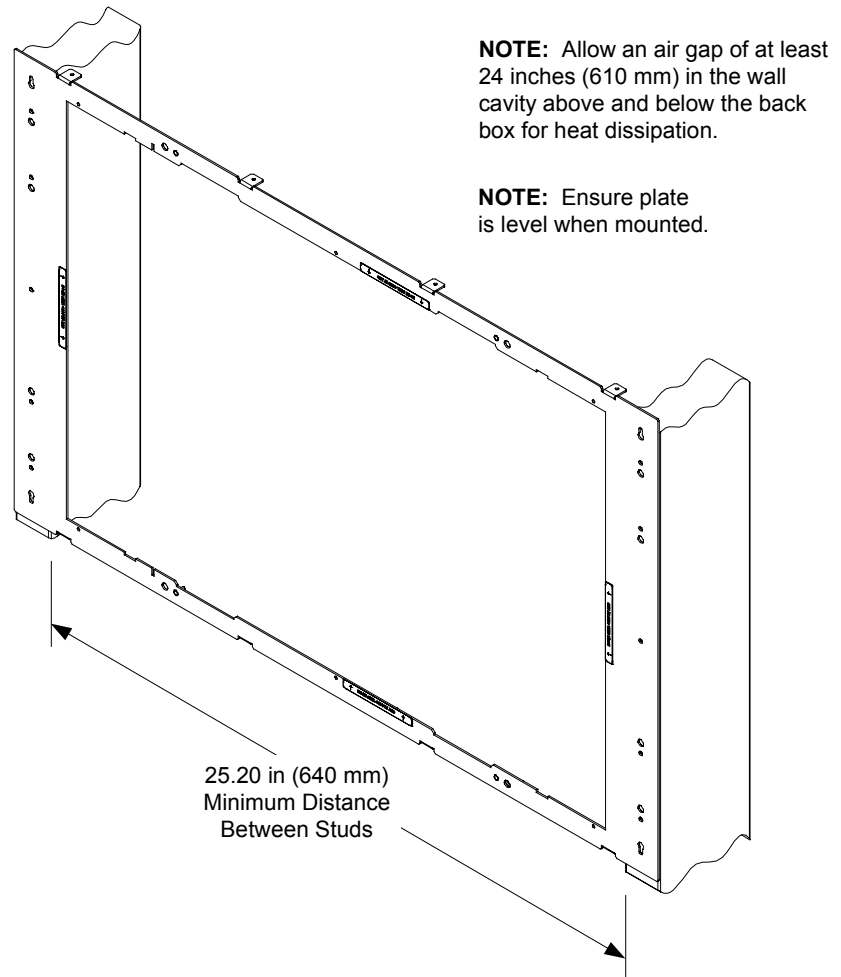

- Note the position of the PMK-V24 and hang drywall over the plate. The opening for the touch screen display is to be made after the drywall is hung.
- After drywall is positioned, a rectangular opening must be made. Position the opening to expose the #06-32 tapped holes along the top and bottom of the plate.

---

**NOTE:** Cut the drywall along the inside edge of the front of the mounting plate. The labels on the front of the mounting plate indicate the perimeter of the opening that should be cut. Refer to **NOTE**s in the illustration above.

---

*Mounted View with Cover Plate*

**NOTE:** Mounting plate is to be covered with drywall and then the cutout made around the inside of the opening. Be sure to leave the six tapped holes on the plate exposed to accept the mounting screws.

**NOTE:** Mounting plate must be level before application of drywall.

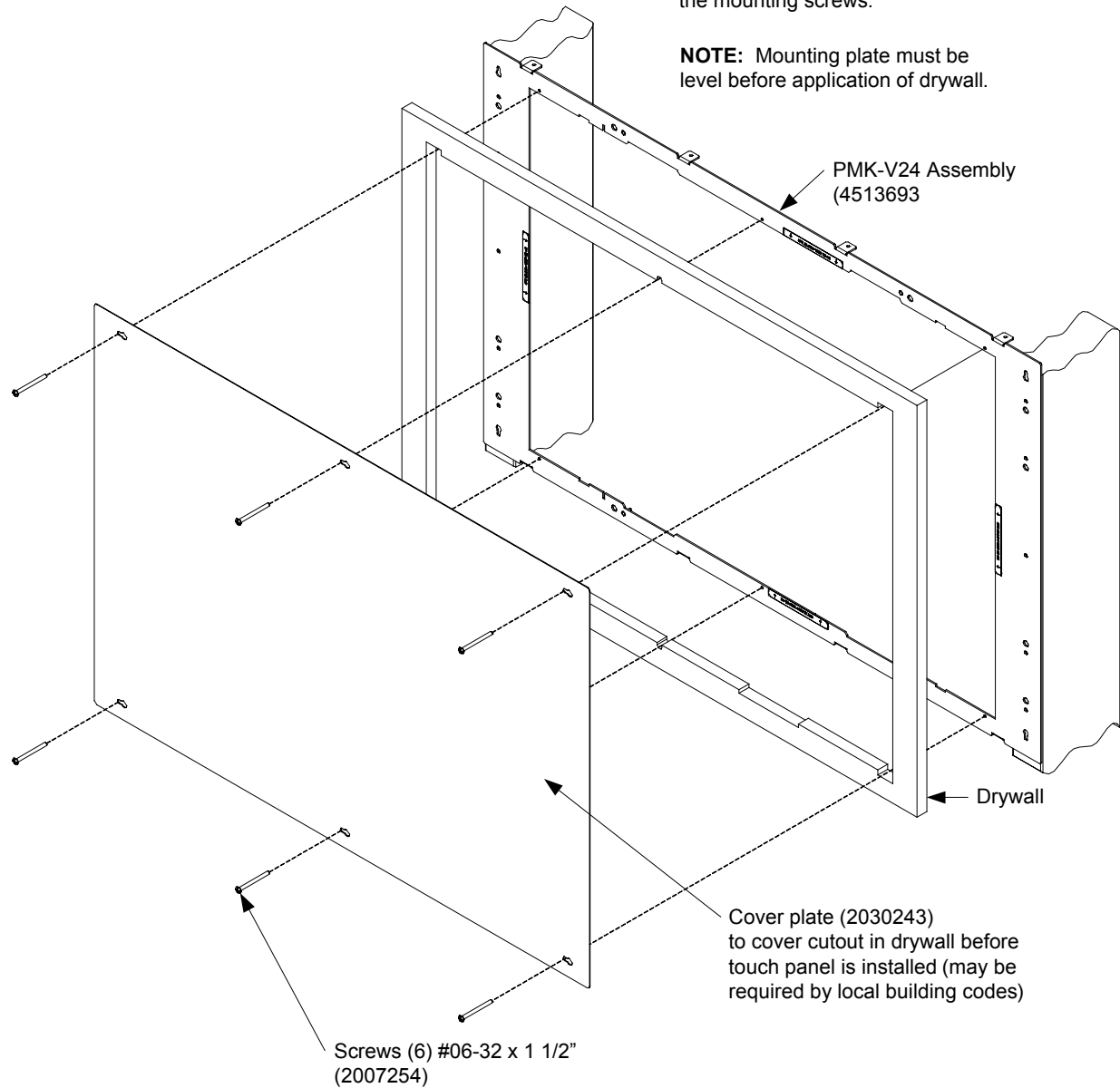

**NOTE:** The six tapped holes on the front of the mounting plate must be exposed to accept the touch screen mounting screws. These holes are found along the top and bottom of the opening made by cutting out the drywall. Refer to the **NOTES** in the illustration above.

## Touch Screen Installation

Complete the installation by either installing the touch screen, leaving the hole open (if permitted by local building codes) or installing the optional cover plate with the included #06-32 x 1 1/2" screws. If the touch screen is to be installed, refer to the latest version of V24R-C V-Panel 24" HD Touch Screen Displays Operations Guide (Doc. 7327) for installation instructions. The document is available from the Crestron Web site ([www.crestron.com/manuals](http://www.crestron.com/manuals)). Refer also to the following comprehensive illustration.

### *Touch Screen Mounting (Exploded View)*

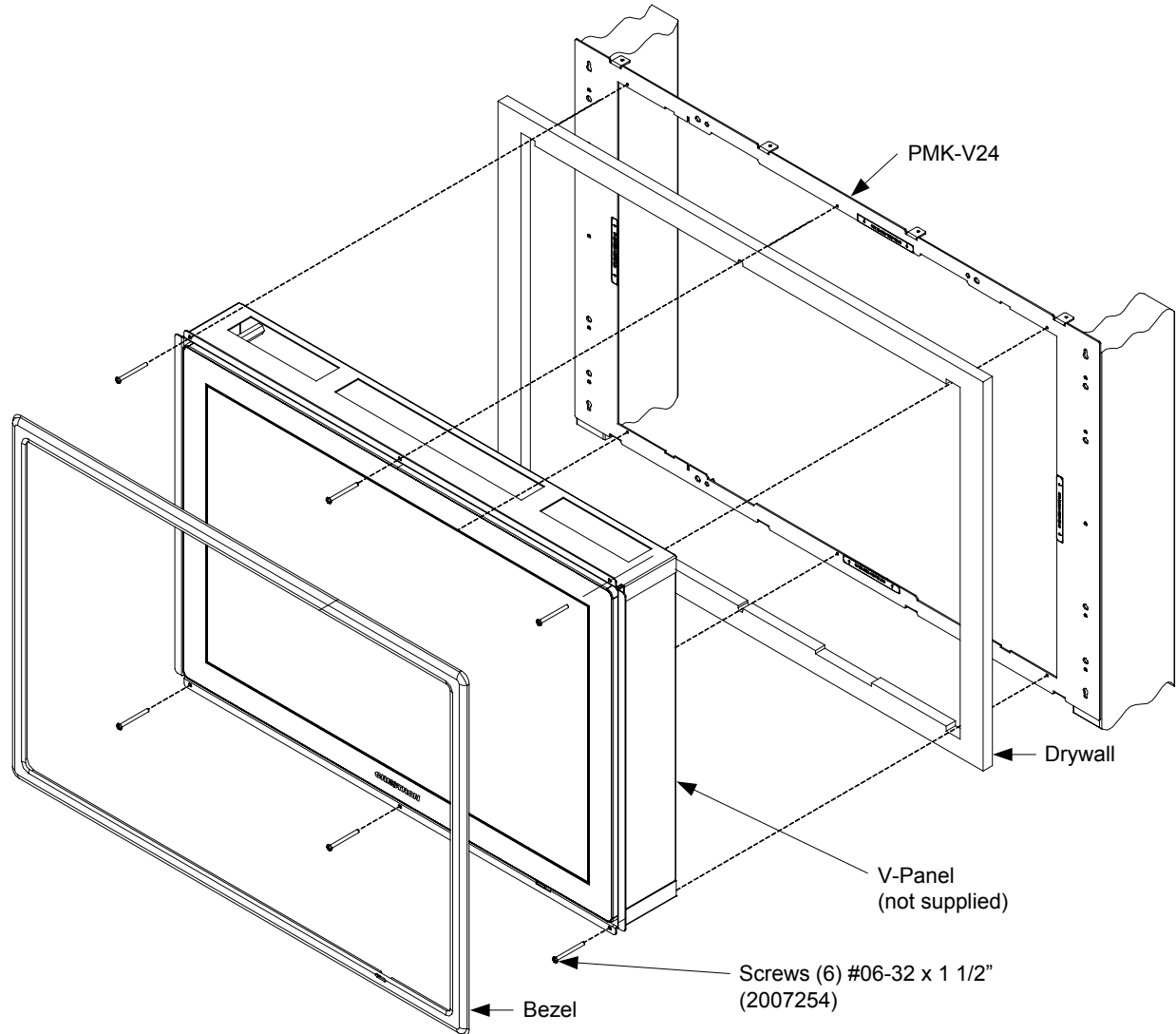

---

## Resources

### Reference Documents

The latest version of all documents mentioned within the guide can be obtained from the Crestron Web site ([www.crestron.com/manuals](http://www.crestron.com/manuals)).

#### *List of Related Reference Documents*

DOCUMENT TITLE
V24R-C V-Panel 24" HD Touch Screen Displays

### Further Inquiries

If you cannot locate specific information or have questions after reviewing this guide, please take advantage of Crestron's award winning customer service team by calling Crestron at 1-888-CRESTRON [1-888-273-7876]. For assistance in your region, please refer to the Crestron Web site ([www.crestron.com/offices](http://www.crestron.com/offices)) for a listing of Crestron worldwide offices.

You can also log onto the online help section of the Crestron Web site ([www.crestron.com/onlinehelp](http://www.crestron.com/onlinehelp)) to ask questions about Crestron products. First-time users will need to establish a user account to fully benefit from all available features.

### Future Updates

As Crestron improves functions, adds new features and extends the capabilities of the PMK-V24, additional information may be made available as manual updates. These updates are solely electronic and serve as intermediary supplements prior to the release of a complete technical documentation revision.

Check the Crestron Web site periodically for manual update availability and its relevance. Updates are identified as an "Addendum" in the Download column.

---

## Return and Warranty Policies

### Merchandise Returns / Repair Service

1. No merchandise may be returned for credit, exchange or service without prior authorization from Crestron. To obtain warranty service for Crestron products, contact an authorized Crestron dealer. Only authorized Crestron dealers may contact the factory and request an RMA (Return Merchandise Authorization) number. Enclose a note specifying the nature of the problem, name and phone number of contact person, RMA number and return address.
2. Products may be returned for credit, exchange or service with a Crestron Return Merchandise Authorization (RMA) number. Authorized returns must be shipped freight prepaid to Crestron, 6 Volvo Drive, Rockleigh, N.J. or its authorized subsidiaries, with RMA number clearly marked on the outside of all cartons. Shipments arriving freight collect or without an RMA number shall be subject to refusal. Crestron reserves the right in its sole and absolute discretion to charge a 15% restocking fee plus shipping costs on any products returned with an RMA.
3. Return freight charges following repair of items under warranty shall be paid by Crestron, shipping by standard ground carrier. In the event repairs are found to be non-warranty, return freight costs shall be paid by the purchaser.

### Crestron Limited Warranty

Crestron Electronics, Inc. warrants its products to be free from manufacturing defects in materials and workmanship under normal use for a period of three (3) years from the date of purchase from Crestron, with the following exceptions: disk drives and any other moving or rotating mechanical parts, pan/tilt heads and power supplies are covered for a period of one (1) year; touch screen display and overlay components are covered for 90 days; batteries and incandescent lamps are not covered.

This warranty extends to products purchased directly from Crestron or an authorized Crestron dealer. Purchasers should inquire of the dealer regarding the nature and extent of the dealer's warranty, if any.

Crestron shall not be liable to honor the terms of this warranty if the product has been used in any application other than that for which it was intended or if it has been subjected to misuse, accidental damage, modification or improper installation procedures. Furthermore, this warranty does not cover any product that has had the serial number altered, defaced or removed.

This warranty shall be the sole and exclusive remedy to the original purchaser. In no event shall Crestron be liable for incidental or consequential damages of any kind (property or economic damages inclusive) arising from the sale or use of this equipment. Crestron is not liable for any claim made by a third party or made by the purchaser for a third party.

Crestron shall, at its option, repair or replace any product found defective, without charge for parts or labor. Repaired or replaced equipment and parts supplied under this warranty shall be covered only by the unexpired portion of the warranty.

Except as expressly set forth in this warranty, Crestron makes no other warranties, expressed or implied, nor authorizes any other party to offer any warranty, including any implied warranties of merchantability or fitness for a particular purpose. Any implied warranties that may be imposed by law are limited to the terms of this limited warranty. This warranty statement supersedes all previous warranties.



**Crestron Electronics, Inc.**  
15 Volvo Drive Rockleigh, NJ 07647  
Tel: 888.CRESTRON  
Fax: 201.767.7576  
[www.crestron.com](http://www.crestron.com)

---

**Installation Guide – DOC. 7190B**  
**(2030786)**  
**12.11**  
Specifications subject to  
change without notice.