

Crestron **BB-3000L**
Wall Mount Back Box

Installation Guide



CRESTRON

This document was prepared and written by the Technical Documentation department at:



Crestron Electronics, Inc.
15 Volvo Drive
Rockleigh, NJ 07647
1-888-CRESTRON

Contents

| | |
|--|----------|
| Wall Mount Back Box: BB-3000L | 1 |
| Description..... | 1 |
| Installation | 3 |
| Assembly | 3 |
| Mounting | 4 |
| Other Mounting Option Accessories | 5 |
| Further Inquiries | 6 |
| Future Updates..... | 6 |
| Return and Warranty Policies | 7 |
| Merchandise Returns / Repair Service | 7 |
| CRESTRON Limited Warranty..... | 7 |

Wall Mount Back Box: BB-3000L

Description

The BB-3000L is a pre-construction mounting option for the TPS-3000L – Isys™ 6” Lectern/Wall Mounted Touchpanel. The table below lists all parts included with the BB-3000L.

Supplied Components

| DESCRIPTION | PART NUMBER | QUANTITY |
|--------------------------------------|------------------|----------|
| Wall Mount Enclosure | MTEN02811-1 | 1 |
| Mounting Plate | MTPL02812-1 | 1 |
| Mounting Bracket | MTBK02800-1 | 2 |
| Cover Plate | MTCV02883-1 | 1 |
| Screw, 06-32, 1/4” L, pan phillips | SR06-32-0R2500-2 | 8 |
| Screw, 08-32, 1/4” L, pan phillips | SR08-8B-0R2500-1 | 1 |
| Screw, 06-32, 1 1/2” L, pan phillips | SR06-32-1R5000-2 | 4 |

The mounted view of the BB-3000L is shown below.

BB-3000L Mounted View (Optional Cover Plate Attached)

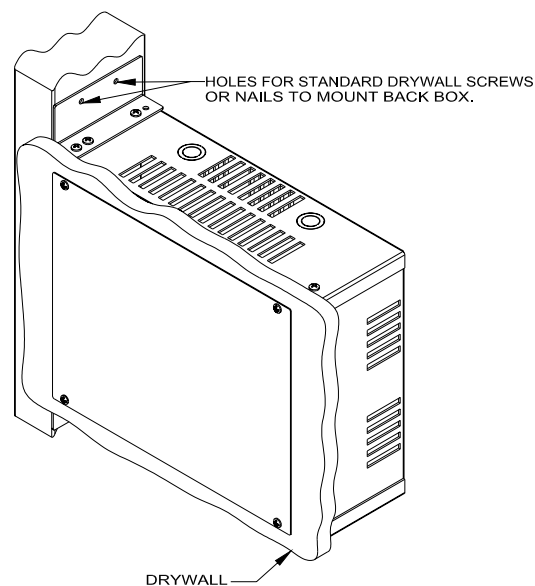

The dimensions of the BB-3000L are shown below.

Dimensional Drawing

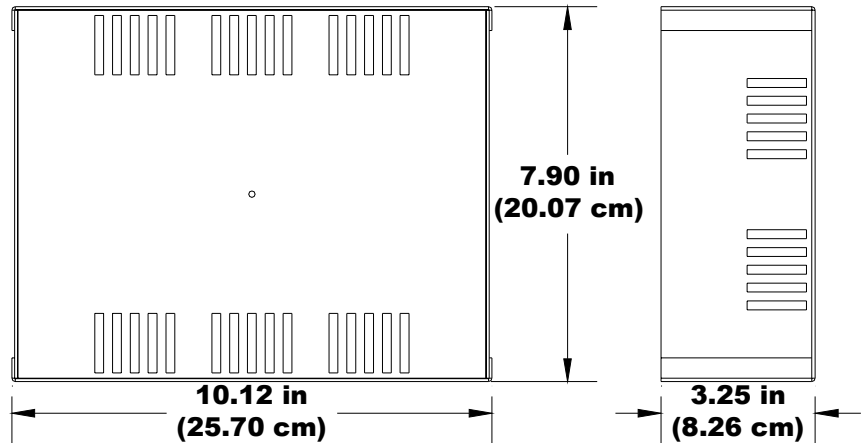

Wall Mount Enclosure

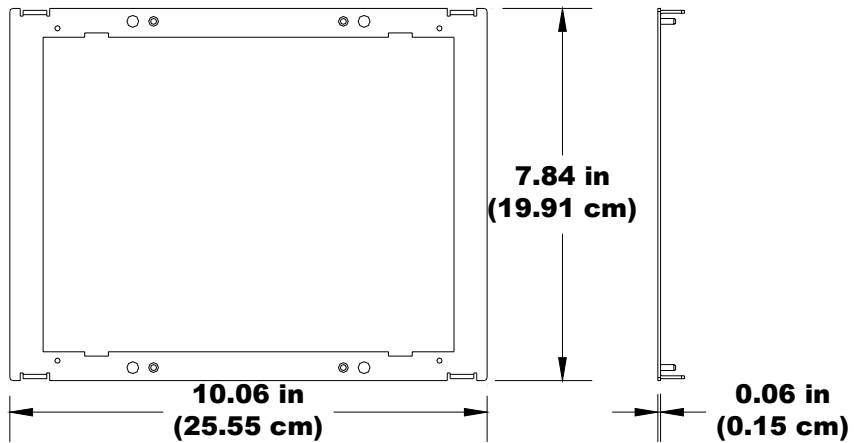

Mounting Plate

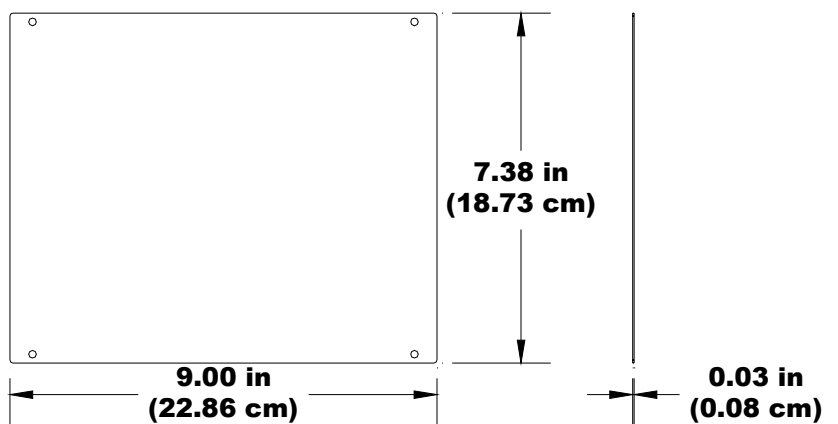

Cover Plate

Installation

Assembly

Required Tools:

- #2 Phillips tip screwdriver

Complete the following assembly procedure in the order provided (refer to illustration below).

1. Remove knockouts as required.
2. Attach supplied #8-32 self-tapping screw to wall mount enclosure for grounding.
3. Attach mounting brackets to wall mount enclosure using supplied (4) #6-32 x 1/4" screws.
4. Attach front mounting plate to wall mount enclosure using supplied (4) #6-32 x 1/4" screws.

Assembly View

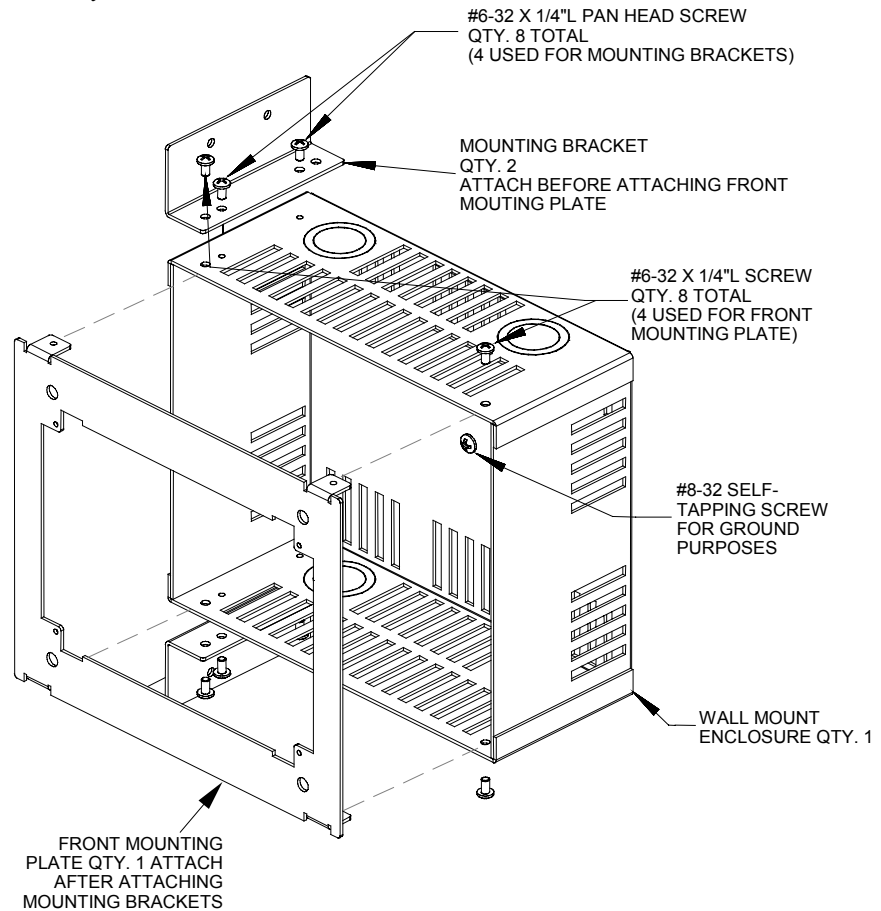

Mounting

Required Tools:

- ❑ #2 Phillips tip screwdriver or hammer
- ❑ Level

Complete the following procedure (refer to illustration below) to mount the assembly.

1. Position assembly to front edge of stud and align it as even and as flush as possible.
2. Use the level and verify that the back box is horizontal. Leveling must be done before proceeding.
3. Attach the assembly to the left or right side of the stud with standard drywall screws or nails (supplied by other). If the mounting brackets cannot be used due to the box location (i.e. above/below a crossbeam), remove the brackets and attach the assembly to the left or right side of stud using the 4 holes on the side of the enclosure.
4. Feed cables through knockout holes.

NOTE: Video connections using the BNC connection must use Right-Angle BNC connectors (supplied by other) to avoid excess stress on the cable.

Mounted View with Cover Plate (Mounting Example - Drywall Not Shown)

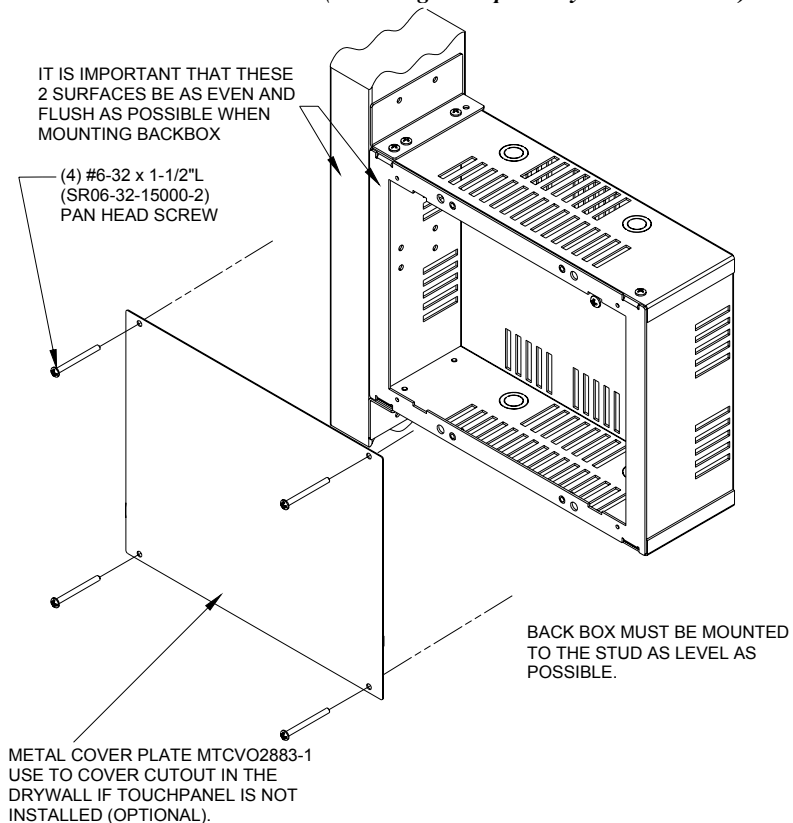

NOTE: Refer to the illustration below for cutout dimensions.

Drywall Cutout Dimensions

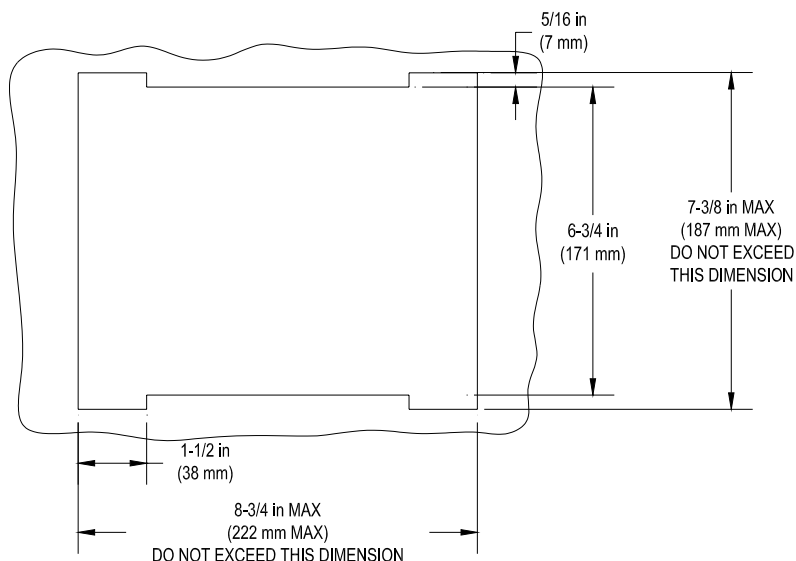

NOTE: Confirm that the 4 tapped holes in the mounting plate are exposed to accept the Touchpanel mounting screws.

5. Complete the installation by either installing the touchpanel, leaving the hole open (if permitted by local building codes), or installing the supplied cover plate with #6-32 x 1½" screws.

Other Mounting Option Accessories

If too much of the cover plate is exposed after the drywall is cut, you may need to patch the area. Crestron provides the following accessories:

- MMK-3000L (Doc. 6021) - for larger repairs to and to fill in larger irregularities around the opening (requires plastering).
- TMK-3000L (Doc. 6020) - for smaller repairs and to provide a smooth edge at the opening. This option provides a finished appearance and is preferred when wallpaper is hung.

The manuals for the MMK-3000L and TMK-3000L are available for review from the Downloads | Product Manuals section of the Crestron website (www.crestron.com).

Further Inquiries

If after reviewing this Installation Guide for the BB-3000L, you cannot locate specific information or have questions, please take advantage of Crestron's award winning customer service team by calling:

- In the US and Canada, call Crestron's corporate headquarters at 1-888-CRESTRON [1-888-273-7876].
- In Europe, call Crestron International at +32-15-50-99-50.
- In Asia, call Crestron Asia at +852-2341-2016.
- In Latin America, call Crestron Latin America at +5255-5093-2160.
- In Australia and New Zealand, call Crestron Pacific at +613-9480-2999.

Future Updates

As Crestron adds improvements to the BB-3000L, additional information may be made available as manual updates. These updates are solely electronic and serve as intermediary supplements prior to the release of a complete technical documentation revision.

Check the Crestron website (www.crestron.com) periodically for manual update availability and its subjective value. Updates are available from the Download | Product Manuals section and are identified as an "Addendum" in the Download column.

Return and Warranty Policies

Merchandise Returns / Repair Service

1. No merchandise may be returned for credit, exchange, or service without prior authorization from CRESTRON. To obtain warranty service for CRESTRON products, contact the factory and request an RMA (Return Merchandise Authorization) number. Enclose a note specifying the nature of the problem, name and phone number of contact person, RMA number, and return address.
2. Products may be returned for credit, exchange, or service with a CRESTRON Return Merchandise Authorization (RMA) number. Authorized returns must be shipped freight prepaid to CRESTRON, Cresskill, N.J., or its authorized subsidiaries, with RMA number clearly marked on the outside of all cartons. Shipments arriving freight collect or without an RMA number shall be subject to refusal. CRESTRON reserves the right in its sole and absolute discretion to charge a 15% restocking fee, plus shipping costs, on any products returned with an RMA.
3. Return freight charges following repair of items under warranty shall be paid by CRESTRON, shipping by standard ground carrier. In the event repairs are found to be non-warranty, return freight costs shall be paid by the purchaser.

CRESTRON Limited Warranty

CRESTRON ELECTRONICS, Inc. warrants its products to be free from manufacturing defects in materials and workmanship under normal use for a period of three (3) years from the date of purchase from CRESTRON, with the following exceptions: disk drives and any other moving or rotating mechanical parts, pan/tilt heads and power supplies are covered for a period of one (1) year; touchscreen display and overlay components are covered for 90 days; batteries and incandescent lamps are not covered.

This warranty extends to products purchased directly from CRESTRON or an authorized CRESTRON dealer. Purchasers should inquire of the dealer regarding the nature and extent of the dealer's warranty, if any.

CRESTRON shall not be liable to honor the terms of this warranty if the product has been used in any application other than that for which it was intended, or if it has been subjected to misuse, accidental damage, modification, or improper installation procedures. Furthermore, this warranty does not cover any product that has had the serial number altered, defaced, or removed.

This warranty shall be the sole and exclusive remedy to the original purchaser. In no event shall CRESTRON be liable for incidental or consequential damages of any kind (property or economic damages inclusive) arising from the sale or use of this equipment. CRESTRON is not liable for any claim made by a third party or made by the purchaser for a third party.

CRESTRON shall, at its option, repair or replace any product found defective, without charge for parts or labor. Repaired or replaced equipment and parts supplied under this warranty shall be covered only by the unexpired portion of the warranty.

Except as expressly set forth in this warranty, CRESTRON makes no other warranties, expressed or implied, nor authorizes any other party to offer any other party to offer any warranty, including any implied warranties of merchantability or fitness for a particular purpose. Any implied warranties that may be imposed by law are limited to the terms of this limited warranty. This warranty statement supercedes all previous warranties.

Trademark Information

All brand names, product names, and trademarks are the sole property of their respective owners. Windows is a registered trademark of Microsoft Corporation. Windows95/98/Me/XP and WindowsNT/2000 are trademarks of Microsoft Corporation.



Crestron Electronics, Inc.
15 Volvo Drive Rockleigh, NJ 07647
Tel: 888.CRESTRON
Fax: 201.767.7576
www.crestron.com

Installation Guide – DOC. 6022
10.02

Specifications subject to
change without notice.