

Crestron **TPS-IMW**
Wall Mounted Interface Module

Operations Guide



This document was prepared and written by the Technical Documentation department at:



Crestron Electronics, Inc.
15 Volvo Drive
Rockleigh, NJ 07647
1-888-CRESTRON

Contents

Wall-Mounted Interface Module: TPS-IMW	1
Introduction	1
Features & Functions	1
Specifications	1
Physical Description	2
Industry Compliance	6
Setup	6
Network Wiring	6
Hardware Hookup	8
Problem Solving	12
Troubleshooting	12
Further Inquiries	14
Future Updates	14
Return and Warranty Policies	15
Merchandise Returns / Repair Service	15
CRESTRON Limited Warranty	15

Wall-Mounted Interface Module: TPS-IMW

Introduction

Features & Functions

The TPS-IMW is designed to serve as an optional interface module for the Creston TPS-3000, TPS-4000, TPS-5000 and TPS-6000 tilt touchpanels. The module provides a clean, 2-gang mountable interface for direct connection to the touchpanel. The TPS-IMW creatively hides most of the connections behind a wall. The two visible telephone-type jacks can be camouflaged with a Decora™ wallplate (not supplied) so that the unit blends into any setting.

NOTE: For the TPS-4500 or TPS-4500V, use the TPS-4500IMW.

Specifications

The following table provides a summary of specifications for the TPS-IMW.

Specifications of the TPS-IMW

SPECIFICATION	DETAILS
Dimensions & Weight	Height: 4.11 in (10.44 cm) Width: 3.50 in (8.89 cm) Depth: 1.51 in (3.82 cm) Weight: 7.7 oz (0.22 kg)

Physical Description

The TPS-IMW, shown in the following diagram, mounts into a 2-gang electrical box (recommended 2.5" depth). The back of the unit is labeled and provides a network connector, video input connector, audio input, and microphone output. Once installed, there are only two RJ-45 connectors (for audio/network/video) visible that provide connections to the touchpanel via the cables supplied with the touchpanel.

Physical Views of the TPS-IMW

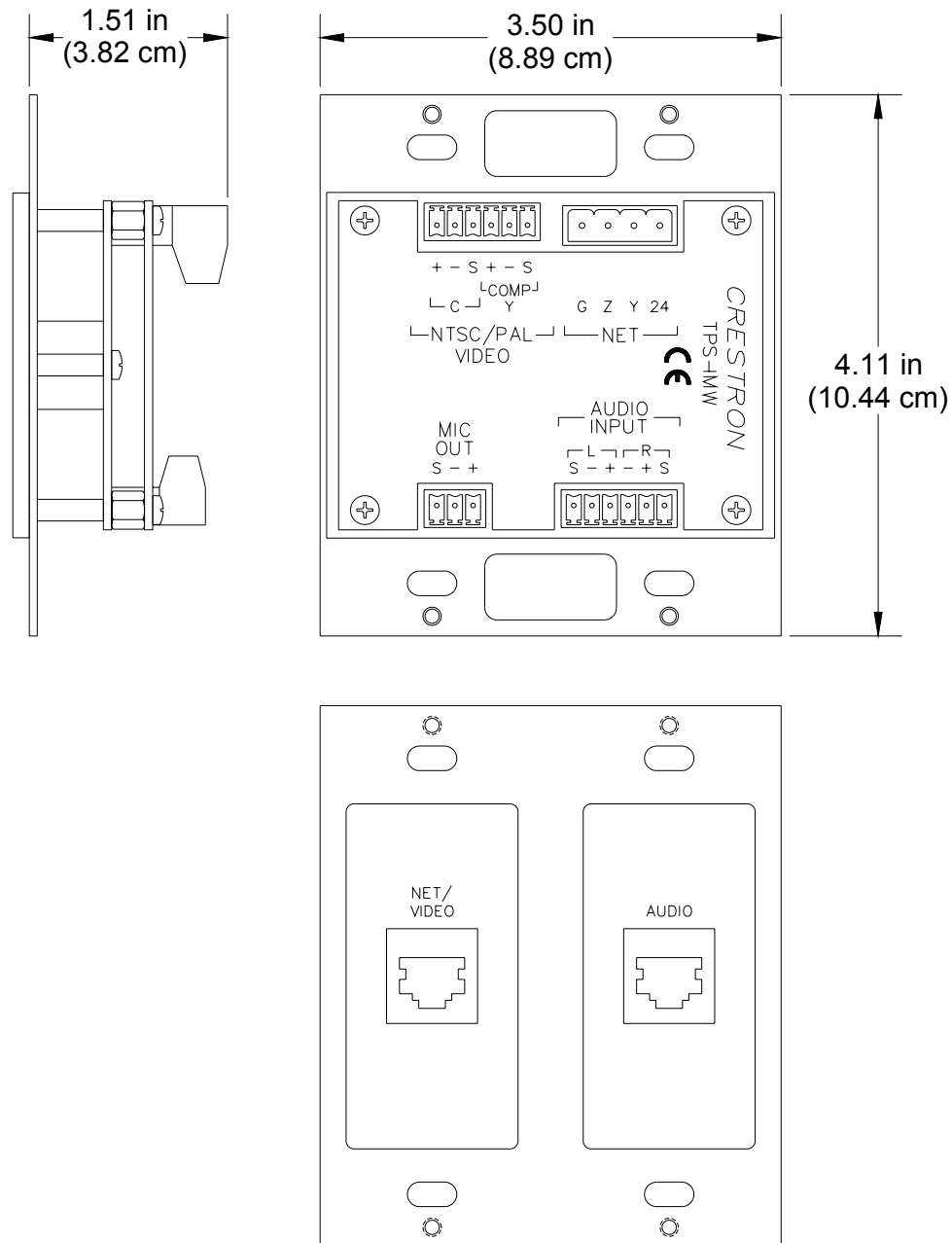

Ports

There are six ports that serve various functions on the TPS-IMW. Refer to the following diagrams and descriptions of each port.

NTSC/PAL VIDEO

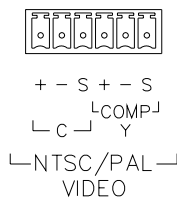

The NTSC/PAL video input uses a 6-position mini-terminal block connector for twisted pair wiring of balanced or unbalanced video signals. The video signal is connected to these ports and requires a TPS-3000, TPS-4000, or installation of the TPS-VID-1 or TPS-VID-2 video card in a TPS-5000 or TPS-6000 touchpanel to display video. Consult the latest revision of the TPS-3000 Operations Guide (Doc. 6076), TPS-4000 Operations Guide (Doc. 6268) or TPS-VID-1/2 Operations & Installation Guide (Doc. 6059) for details. A description of the pinouts is shown in the following table.

NTSC/PAL Balanced Video Input Pinouts

PIN	DESCRIPTION	PIN	DESCRIPTION
C(+)	Chrominance (Positive)	Y(+)	Luminance (Positive)
C(-)	Chrominance (Negative)	Y(-)	Luminance (Negative)
C(S)	Chrominance (Shield)	Y(S)	Luminance (Shield)

To connect S-video signals, chrominance and luminance signals must be connected to the “C” and “Y” terminals. To view composite signals, the signal should be connected to the “Y” terminal.

NOTE: Except for differential input (balanced) video signal, the six-pin video connector with jumpers (included) should be installed at all times. Refer to “Hardware Hookup” on page 8 for details.

NET

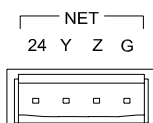

This four-position terminal block connector is used to connect to other Cresnet peripherals in a system and provide network power to the touchpanel if an external power pack is not used. If making network connections to a control system or Cresnet peripherals, refer to “Network Wiring” on page 6.

AUDIO INPUT

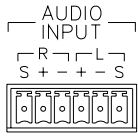

The port mates with a six-position mini-terminal block connector (supplied) and provides balanced and/or unbalanced audio input. A description of the pinouts is shown in the following table.

AUDIO INPUT Pinouts

PIN	DESCRIPTION	PIN	DESCRIPTION
S	Shield	L +	Left Positive
R +	Right Positive	L-	Left Negative
R -	Right Negative	S	Shield

MIC OUT

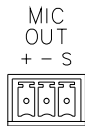

The port mates with a three-position mini-terminal block connector (supplied) and produces line level differential output. Description of the pinouts is shown in the following table.

MIC OUT Pinouts

PIN	DESCRIPTION
+	Positive
-	Negative
S	Shield

NET/VIDEO (To Panel)

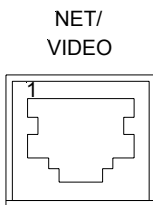

This 10-pin RJ-45 connection mates with the TPS-3000, TPS-4000, TPS-5000, or TPS-6000 touchpanel. Refer to the descriptions and pinout table that follow this paragraph. The 10-pin net/video cable assembly to connect the touchpanel to the TPS-IMW is supplied. Even though the 8-pin audio cable may fit into the port, do not use it.

This port provides the Cresnet connection to the touchpanel. This port also provides composite or S-video input for the built-in video card (with the purchase of a TPS-3000, TPS-4000, or installation of the TPS-VID-1/2 in a TPS-5000 or TPS-6000 touchpanel). Consult the latest revision of the TPS-3000 Operations Guide (Doc. 6076), TPS-4000 Operations Guide (Doc. 6268) or TPS-VID-1/2 Operations & Installation Guide (Doc. 6059) for details.

NET/VIDEO Pinouts

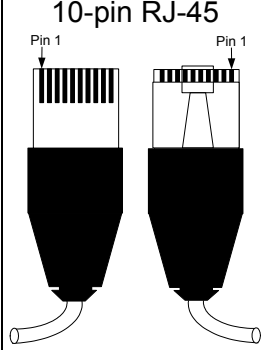
TYPE	PIN	DESIGNATION	DESCRIPTION
	1	+24V	Power (Network)
	2	GND	Ground (Network)
	3	C+	Chrominance (Positive) /Composite 2
	4	C-	Chrominance (Negative) /Composite 2
	5	Y	Data (Network)
	6	Z	Data (Network)
	7	Y+	Luminance (Positive) /Composite 1
	8	Y-	Luminance (Negative) /Composite 1
	9	GND	Ground (Network)
	10	+24V	Power (Network)

To determine the location of pin 1, hold the cable so that the end of the 10-pin RJ-45 connector is facing away from you, with the clip side down and the copper side up. The copper connector on the far left is pin 1.

CAUTION: The 10-pin RJ-45 net/video connector cable supplied by Crestron is a custom cable and is the only one that should be used. The end of the cable has a metal shield that is required to protect the equipment. Using non-Crestron cables will result in damage to the product.

AUDIO (To Panel)

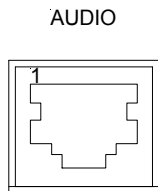

This 8-pin RJ-45 mates with the TPS-3000, TPS-4000, TPS-5000, or TPS-6000 touchpanel. The 8-pin audio cable assembly is supplied. Even though the 10-pin net/video cable may fit into the port, do not use it. This port provides audio input to the touchpanel and microphone output from the touchpanel. A description of the pinouts is shown in the following table.

AUDIO Pinouts

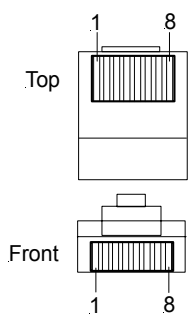
TYPE	PIN	DESIGNATION	DESCRIPTION
	1	L+	Left Input (Positive)
	2	L-	Left Input (Negative)
	3	GND/Shield	Audio Input Ground/Shield
	4	R+	Right Input (Positive)
	5	R-	Right Input (Negative)
	6	GND/Shield	Mic Output Ground/Shield
	7	M+	Mic Output (Positive)
	8	M-	Mic Output (Negative)

To determine the location of pin 1, hold the cable so that the end of the 8-pin RJ-45 connector is facing away from you, with the clip side down and the copper side up. The copper connector on the far left is pin 1.

Industry Compliance

As of the date of manufacture, the TPS-IMW has been tested and found to comply with specifications for CE marking and standards per EMC and Radiocommunications Compliance Labelling.



Setup

Network Wiring

CAUTION: Use only Crestron power supplies for Crestron equipment. Failure to do so could cause equipment damage or void the Crestron warranty.

CAUTION: Provide sufficient power to the system. Insufficient power can lead to unpredictable results or damage to the equipment. Please use the Crestron Power Calculator (www.crestron.com/dealer-tech_resources/power_calculator.asp) to help calculate how much power is needed for the system.

CAUTION: Possible equipment damage if miswired.

NOTE: When installing network wiring, refer to the latest revision of the wiring diagram(s) appropriate to your specific system configuration, available from the Downloads | Product Manuals | Wiring Diagrams section of the Crestron website (www.crestron.com).

NOTE: Do not power up system until all wiring is verified. Care should be taken to ensure data (Y, Z) and power (24, G) connections are not crossed.

NOTE: All network wiring must consist of two twisted-pairs. One twisted pair is the +24V conductor and the GND conductor and the other twisted pair is the Y conductor and the Z conductor.

NOTE: For larger networks (i.e., greater than 28 network devices), it may be necessary to add a Cresnet Hub/Repeater (CNXHUB) to maintain signal quality throughout the network. Also, for networks with lengthy cable runs or varying types of network devices, it may be desirable to add a hub/repeater after only 20 network devices.

When calculating the wire gauge for a particular Cresnet run, the length of the run and the Cresnet power usage of each Cresnet unit to be connected must be taken into consideration. If Cresnet units are to be daisy-chained on the run, the Cresnet power usage of each network unit to be daisy-chained must be added together to determine the Cresnet power usage of the entire chain. If the unit is a home-run from a Crestron system power supply network port, the Cresnet power usage of that unit is the Cresnet power usage of the entire run. The length of the run in feet and the Cresnet power usage of the run should be used in the following resistance equation to calculate the value on the right side of the equation.

Resistance Equation

$$R < \frac{40,000}{L \times P}$$

Where: R = Resistance (refer to the following table). L = Length of run (or chain) in feet. P = Cresnet power usage of entire run (or chain).

The required wire gauge should be chosen such that the resistance value is less than the value calculated in the resistance equation. Refer to the following table.

Wire Gauge Values

RESISTANCE (R)	WIRE GAUGE
4	16
6	18
10	20
15	22
13	Doubled CAT5
8.7	Tripled CAT5

NOTE: When daisy-chaining Cresnet units, strip the ends of the wires carefully to avoid nicking the conductors. Twist together the ends of the wires that share a pin on the network connector, and tin the twisted connection. Apply solder only to the ends of the twisted wires. Avoid tinning too far up the wires or the end becomes brittle. Insert the tinned connection into the Cresnet connector and tighten the retaining screw. Repeat the procedure for the other three conductors.

Hardware Hookup

Connections to the Back of the TPS-IMW

The TPS-IMW serves as interface between the touchpanel and the Cresnet system. Refer to the illustration after this paragraph for proper connections; apply power last. When making network connections to a control system or Cresnet peripherals, refer to “Network Wiring” on page 6. It is not necessary to make connections to a video source unless a TPS-3000 and/or TPS-4000 touchpanel is used or a TPS-VID-1/2 has been installed into a TPS-5000 or TPS-6000 touchpanel and a video window object resides on a page within the uploaded Crestron VisionTools[®] Pro-e (VT Pro-e) project.

NOTE: When connecting the net/video cable from the interface module to the touchpanel, exceeding a cable length of 30 feet will significantly degrade the video signal. To maintain high-quality video, **DO NOT** daisy-chain cables or Crestron TPSBLOCK-10 cables longer than 30 feet. Contact Crestron for the maximum available cable length.

Hardware Hookup Connections to the Back of the TPS-IMW

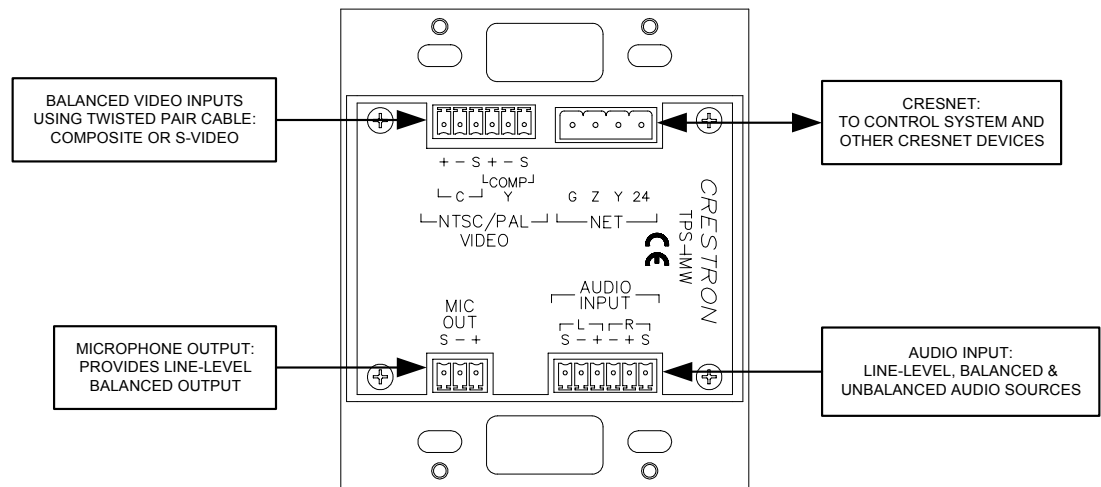

A video source can be connected to a TPS-3000, TPS-4000, or a TPS-VID1/2 installed in a TPS-5000 or TPS-6000 touchpanel. The TPS-IMW allows for the connection of balanced or unbalanced video signals using twisted pair cable. Refer to the following diagrams to connect balanced or unbalanced video signals.

Balanced Video Connection Unbalanced Video Connection

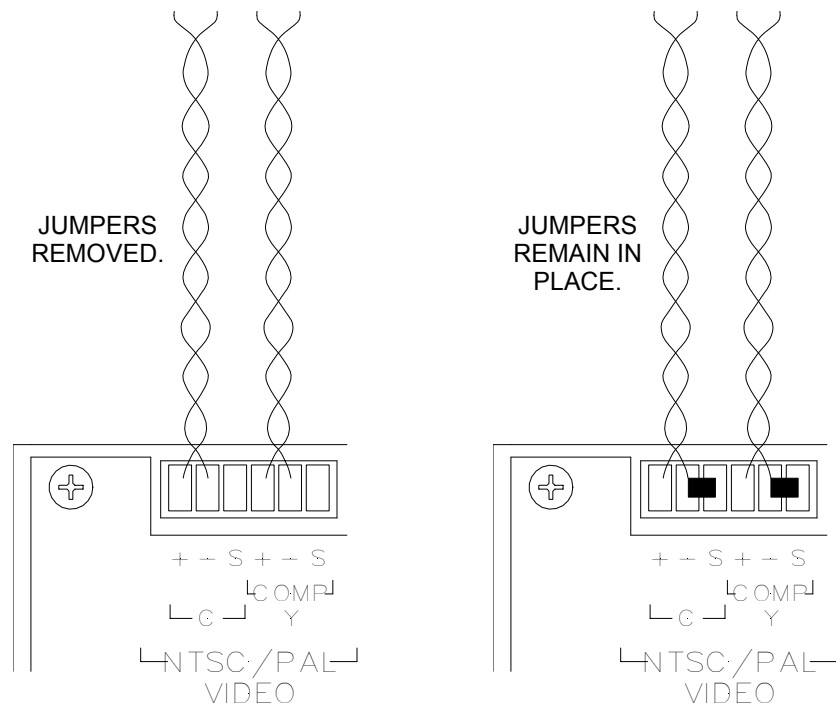

If there is no video signal, do not make a connection to the port, but leave the connector with the jumpers attached to the NTSC/PAL VIDEO six-position mini-terminal block connector on the TPS-IMW.

Installation into the Electrical Box

The TPS-IMW mounts into a 2-gang electrical box (recommended 2.5" depth). Verify that the unit is installed into the electrical box as shown in the following diagram. Secure the TPS-IMW to the electrical box with the four #6-32 flat-head slotted screws (supplied).

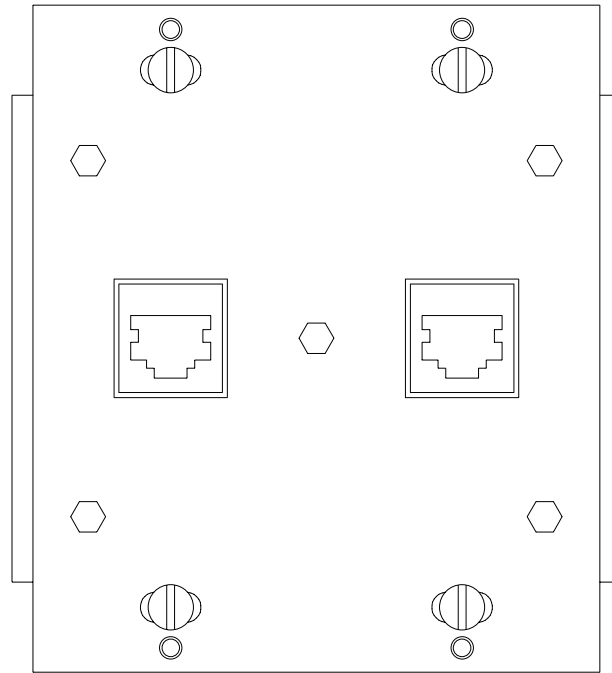
Installation of the TPS-IMW

Once the TPS-IMW is installed into a 2-gang electrical box, it can be covered with a Decora wallplate (purchased separately).

Remove the backing from the tape on the back of the two silk-screened insert plates (supplied). Affix each insert plate into its proper opening in the wallplate. For the proper orientation of the two insert plates with respect to the installed TPS-IMW, refer to the following diagram.

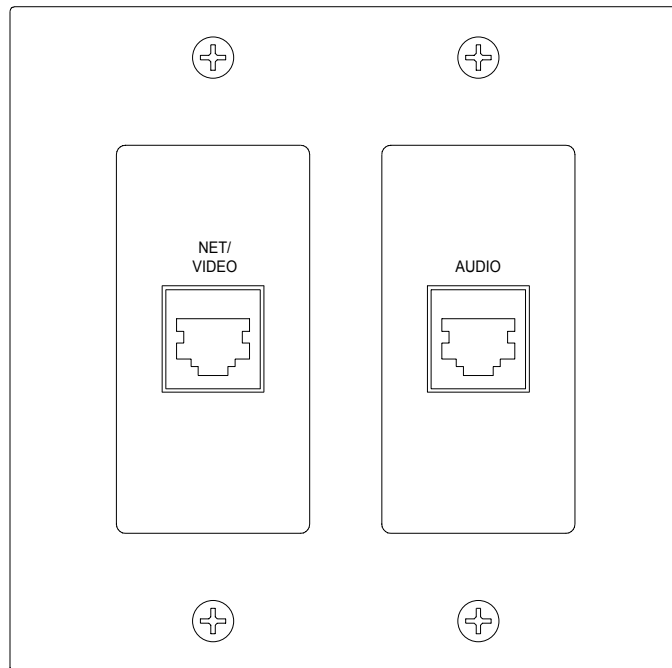
Orientation of the Insert Plates

Connect the TPS-IMW to the touchpanel using the supplied network/video (10-pin) and audio (eight-pin) cables.

NOTE: The included AUDIO cable has a connector with a blue cover to match the blue lettering on the TPS-IMW. As older AUDIO cables may not have the blue cover, be sure to insert the AUDIO cable into the AUDIO port.

NOTE: Do not confuse the 8-pin audio cable with the 10-pin net/video cable.

Problem Solving

Troubleshooting

The following table provides corrective action for possible trouble situations. If further assistance is required, please contact a Crestron customer service representative.

TPS-IMW Troubleshooting

TROUBLE	POSSIBLE CAUSE(S)	CORRECTIVE ACTION
Touchpanel does not function.	Touchpanel is not receiving power.	Confirm that power is supplied via the Cresnet connector.
	Touchpanel is not communicating to the network.	Use Viewport (via SIMPL Windows or VT Pro-e) to poll the network. Verify network connection to the touchpanel.
No power to the touchpanel.	The 8-pin RJ-45 audio cable is mistakenly connected to the NET/VIDEO port.	Replace the 8-pin audio cable with the 10-pin net/video cable.
Video window on touchpanel has no display.	Improper video connection.	Verify proper connections on the touchpanel and TPS-IMW.
	Incorrect video cable used.	Verify that the 10-pin net/video cable assembly is used to connect the NET/VIDEO port of the touchpanel to the TPS-IMW.
	TPS-VID-1/2 improperly installed.	Follow installation procedures for TPS-VID-1/2.

(continued on next page)

TPS-IMW Troubleshooting (continued)

TROUBLE	POSSIBLE CAUSE(S)	CORRECTIVE ACTION
Video window on touchpanel has no display.	Incorrect video format selection.	Select the proper video input configuration in the touchpanel configuration SETUP MENU.
	Incorrect VT Pro-e project file loaded.	Make sure that video window object resides in project, re-compile, and reload.
	Damaged connector pins.	Inspect connector pins. If bent, carefully re-straighten. If broken, contact Crestron customer service.
Video colors are wrong and/or moving	Touchpanel is set to auto-detect or S-video when two composite signals are plugged into the TPS-IMW.	Switch to "composite" video.

Further Inquiries

If you cannot locate specific information or have questions after reviewing this guide, please take advantage of Crestron's award winning customer service team by calling the Crestron corporate headquarters at 1-888-CRESTRON [1-888-273-7876]. For assistance in your local time zone, refer to the Crestron website (www.crestron.com) for a listing of Crestron worldwide offices.

You can also log onto the online help section of the Crestron website (www.crestron.com) to ask questions about Crestron products. First-time users will need to establish a user account to fully benefit from all available features.

Future Updates

As Crestron improves functions, adds new features, and extends the capabilities of the TPS-IMW, additional information may be made available as manual updates. These updates are solely electronic and serve as intermediary supplements prior to the release of a complete technical documentation revision.

Check the Crestron website (www.crestron.com) periodically for manual update availability and its relevance. Updates are available from the Downloads | Product Manuals section and are identified as an “Addendum” in the Download column.

Return and Warranty Policies

Merchandise Returns / Repair Service

1. No merchandise may be returned for credit, exchange, or service without prior authorization from CRESTRON. To obtain warranty service for CRESTRON products, contact the factory and request an RMA (Return Merchandise Authorization) number. Enclose a note specifying the nature of the problem, name and phone number of contact person, RMA number, and return address.
2. Products may be returned for credit, exchange, or service with a CRESTRON Return Merchandise Authorization (RMA) number. Authorized returns must be shipped freight prepaid to CRESTRON, 6 Volvo Drive, Rockleigh, N.J., or its authorized subsidiaries, with RMA number clearly marked on the outside of all cartons. Shipments arriving freight collect or without an RMA number shall be subject to refusal. CRESTRON reserves the right in its sole and absolute discretion to charge a 15% restocking fee, plus shipping costs, on any products returned with an RMA.
3. Return freight charges following repair of items under warranty shall be paid by CRESTRON, shipping by standard ground carrier. In the event repairs are found to be non-warranty, return freight costs shall be paid by the purchaser.

CRESTRON Limited Warranty

CRESTRON ELECTRONICS, Inc. warrants its products to be free from manufacturing defects in materials and workmanship under normal use for a period of three (3) years from the date of purchase from CRESTRON, with the following exceptions: disk drives and any other moving or rotating mechanical parts, pan/tilt heads and power supplies are covered for a period of one (1) year; touchscreen display and overlay components are covered for 90 days; batteries and incandescent lamps are not covered.

This warranty extends to products purchased directly from CRESTRON or an authorized CRESTRON dealer. Purchasers should inquire of the dealer regarding the nature and extent of the dealer's warranty, if any.

CRESTRON shall not be liable to honor the terms of this warranty if the product has been used in any application other than that for which it was intended, or if it has been subjected to misuse, accidental damage, modification, or improper installation procedures. Furthermore, this warranty does not cover any product that has had the serial number altered, defaced, or removed.

This warranty shall be the sole and exclusive remedy to the original purchaser. In no event shall CRESTRON be liable for incidental or consequential damages of any kind (property or economic damages inclusive) arising from the sale or use of this equipment. CRESTRON is not liable for any claim made by a third party or made by the purchaser for a third party.

CRESTRON shall, at its option, repair or replace any product found defective, without charge for parts or labor. Repaired or replaced equipment and parts supplied under this warranty shall be covered only by the unexpired portion of the warranty.

Except as expressly set forth in this warranty, CRESTRON makes no other warranties, expressed or implied, nor authorizes any other party to offer any warranty, including any implied warranties of merchantability or fitness for a particular purpose. Any implied warranties that may be imposed by law are limited to the terms of this limited warranty. This warranty statement supercedes all previous warranties.

Trademark Information

All brand names, product names, and trademarks are the sole property of their respective owners. Windows is a registered trademark of Microsoft Corporation. Windows95/98/Me and WindowsNT/2000 are trademarks of Microsoft Corporation.



Crestron Electronics, Inc.
15 Volvo Drive Rockleigh, NJ 07647
Tel: 888.CRESTRON
Fax: 201.767.7576
www.crestron.com

Operations Guide – DOC. 5857A
11.04

Specifications subject to
change without notice.