

Crestron MP-FS-PAS
FreeSpeech® PA Audio Sensor
Operations & Installation Guide



Further Inquiries

To locate specific information or resolve questions after reviewing this guide, contact Crestron's True Blue Support at 1-888-CRESTRON [1-888-273-7876] or refer to the listing of Crestron worldwide offices on the Crestron Web site (www.crestron.com/offices) for assistance within a particular geographic region.

To post a question about Crestron products, log onto the Online Help section of the Crestron Web site (www.crestron.com/onlinehelp). First-time users must establish a user account to fully benefit from all available features.

Future Updates

As Crestron improves functions, adds new features and extends the capabilities of the MP-FS-PAS, additional information may be made available as manual updates. These updates are solely electronic and serve as intermediary supplements prior to the release of a complete technical documentation revision.

Check the Crestron Web site periodically for manual update availability and its relevance. Updates are identified as an "Addendum" in the Download column.

Crestron Electronics, Inc.
 15 Volvo Drive Rockleigh, NJ 07647
 Tel: 888.CRESTRON
 Fax: 201.767.7576
www.crestron.com

Operations & Installation Guide - DOC. 7198B
(2031317)
08.12

Specifications subject to change without notice.

Regulatory Compliance

This product is Listed to applicable UL Standards and requirements by Underwriters Laboratories Inc.



As of the date of manufacture, the MP-FS-PAS has been tested and found to comply with specifications for CE marking and standards per EMC and Radiocommunications Compliance Labelling.



DESCRIPTION

The MP-FS-PAS mounts to the front face of a public address (PA) loudspeaker to sense whenever an audio signal is present. Connects to the **MUTE SENSOR** input of a FreeSpeech® Wireless Mic Receiver (MP-FS-RX1 or MP-FS-RX2)* allowing all audio signals through the wireless mic receiver to be muted during a PA announcement.

MP-FS-PAS

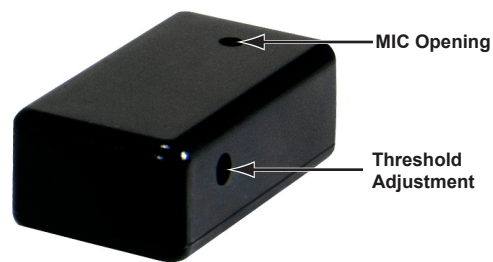

* Item(s) sold separately or as part of a MP-FS100_PAK or MP-FS200_PAK system package.

SPECIFICATIONS

Specifications for the MP-FS-PAS are listed in the following table.

MP-FS-PAS Specifications

SPECIFICATION	DETAILS
Environmental Temperature Humidity	41° to 104° F (5° to 40° C) 10% to 90% RH (non-condensing)
Enclosure Housing Mounting	Plastic, black Surface mount (adhesive fastener included)
Dimensions Height Width Depth	1.44 in (37 mm) 0.72 in (19 mm) 0.52 in (14 mm)
Weight	0.3 oz (9 g)

MP-FS-PAS Overall Dimensions

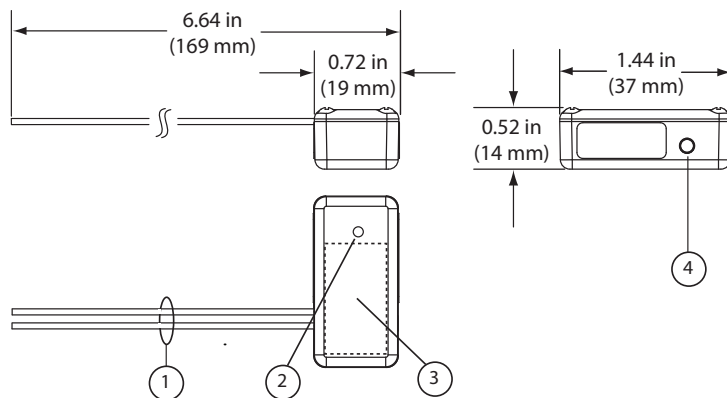

Connectors, Controls & Indicators

#	CONNECTORS, CONTROLS & INDICATORS	DESCRIPTION
1	Flying Leads	(2) Red/Black 24 AWG ~6 in (152 mm) wires
2	MIC Opening	Allows MP-FS-PAS to sense whenever an audio signal is present
3	Adhesive Area	Location for attachment of hook and loop tape to secure MP-FS-PAS to PA speaker
4	Threshold	Recessed screwdriver-adjustable rotary control. Turning the control CCW reduces sensitivity to sound from the PA speaker; turning it CW increases sensitivity to sound from the speaker.

INSTALLATION / OPERATION

Installation of the MP-FS-PAS consists of the following:

1. Install a 2-conductor cable (minimum 24 AWG) up to 50 feet (~15 meters) maximum, between the PA speaker location and the MP-FS-RX1/RX2 location. As an alternative, use the red and black wires of Crestron's CBL-PWR-CTRL-P-TL-50 or equivalent cable.
 - Avoid locating the PA speaker in high vibration areas or draft areas, such as near air conditioning or open windows.
 - Make sure the PA speaker and the MP-FS-PAS are not located where the FreeSpeech system speakers inadvertently trigger the MP-FS-PAS.
2. Use the supplied hook and loop tape to attach the MP-FS-PAS to the front face of the PA speaker. Refer to the first page for adhesive area.
3. Use the supplied wire nuts to connect the flying leads of the MP-FS-PAS to the stripped ends of two wires in the installed cable.
4. Connect the other end of the two-wire cable to the **MUTE SENSOR S** and **G** terminal positions of the supplied 2-pin 3.5mm detachable terminal block for the MP-FS-RX1/RX2.

NOTE: The MP-FS-PAS red wire terminates at the **MUTE SENSOR** terminal **S**; the black wire terminates at terminal **G**.

NOTE: If a cable shield is used, also connect the shield to terminal **G**.

5. If necessary, adjust the recessed threshold control during PA speaker operation to ensure proper triggering of the MP-FS-PAS.

Return and Warranty Policies

Merchandise Returns / Repair Service

1. No merchandise may be returned for credit, exchange or service without prior authorization from Crestron. To obtain warranty service for Crestron products, contact an authorized Crestron dealer. Only authorized Crestron dealers may contact the factory and request an RMA (Return Merchandise Authorization) number. Enclose a note specifying the nature of the problem, name and phone number of contact person, RMA number and return address.
2. Products may be returned for credit, exchange or service with a Crestron Return Merchandise Authorization (RMA) number. Authorized returns must be shipped freight prepaid to Crestron, 6 Volvo Drive, Rockleigh, N.J. or its authorized subsidiaries, with RMA number clearly marked on the outside of all cartons. Shipments arriving freight collect or without an RMA number shall be subject to refusal. Crestron reserves the right in its sole and absolute discretion to charge a 15% restocking fee plus shipping costs on any products returned with an RMA.
3. Return freight charges following repair of items under warranty shall be paid by Crestron, shipping by standard ground carrier. In the event repairs are found to be non-warranty, return freight costs shall be paid by the purchaser.

Crestron Limited Warranty

Crestron Electronics, Inc. warrants its products to be free from manufacturing defects in materials and workmanship under normal use for a period of three (3) years from the date of purchase from Crestron, with the following exceptions: disk drives and any other moving or rotating mechanical parts, pan/tilt heads and power supplies are covered for a period of one (1) year; touch screen display and overlay components are covered for 90 days; batteries and incandescent lamps are not covered.

This warranty extends to products purchased directly from Crestron or an authorized Crestron dealer. Purchasers should inquire of the dealer regarding the nature and extent of the dealer's warranty, if any.

Crestron shall not be liable to honor the terms of this warranty if the product has been used in any application other than that for which it was intended or if it has been subjected to misuse, accidental damage, modification or improper installation procedures. Furthermore, this warranty does not cover any product that has had the serial number altered, defaced or removed.

This warranty shall be the sole and exclusive remedy to the original purchaser. In no event shall Crestron be liable for incidental or consequential damages of any kind (property or economic damages inclusive) arising from the sale or use of this equipment. Crestron is not liable for any claim made by a third party or made by the purchaser for a third party.

Crestron shall, at its option, repair or replace any product found defective, without charge for parts or labor. Repaired or replaced equipment and parts supplied under this warranty shall be covered only by the unexpired portion of the warranty.

Except as expressly set forth in this warranty, Crestron makes no other warranties, expressed or implied, nor authorizes any other party to offer any warranty, including any implied warranties of merchantability or fitness for a particular purpose. Any implied warranties that may be imposed by law are limited to the terms of this limited warranty. This warranty statement supersedes all previous warranties.

The specific patents that cover Crestron products are listed at patents.crestron.com

Crestron, the Crestron logo, and FreeSpeech are trademarks or registered trademarks of Crestron Electronics, Inc. in the United States and/or other countries. UL and the UL logo are either trademarks or registered trademarks of Underwriters Laboratories, Inc. in the United States and/or other countries. Other trademarks, registered trademarks, and trade names may be used in this document to refer to either the entities claiming the marks and names or their products. Crestron disclaims any proprietary interest in the marks and names of others.
©2012 Crestron Electronics, Inc.