

Mullion Mount Kit for TSW-770 and TSW-1070

The Crestron® [TSW-770/1070-MUMK](#) is a mullion mount kit that is used to attach a TSW-770 or TSW-1070 touch screen to the mullion of an interior glass wall, window, or partition. The MUMK mounts the touch screen to the left or right of any hollow, metallic vertical mullion, and two mounting brackets are provided that allow the MUMK to be installed in one of two configurations (side mount or front mount). Wiring is run to the touch screen from inside the mullion.



In the Box

- 1 TSW-770/1070-MUMK, Mullion Mount Kit

Additional Items

- 1 Bracket, Mullion, Front Mount (2053274)
- 1 Bracket, Mullion, Side Mount (2053273)
- 2 Jacknut, 6-32 (2053371)
- 2 Screw, 4-40 x 1/4 in., Undercut Head, Phillips (2007152)
- 4 Screw, 4-40 x 1/2 in., Undercut Head, Phillips (2007174)
- 4 Screw, 4-40 x 3/4 in., Flat Head, Phillips (2029110)
- 2 Screw, 6-32 x 3/8 in., Socket Head (2007230)
- 2 Screw, 6-32 x 7/17 in., Pan Head, Phillips (2007236)
- 2 Screw, 6-32 x 1/2 in., Flat Head, Phillips (2007241)
- 2 Screw, 6-32 x 1/2 in., Pan Head, Phillips (2007240)
- 1 Screw, 6-32 x 1 in., Truss Head, Combo (2054883)
- 2 Spacer, 06 (2007095)
- 1 Template, Mullion Cutout (4529900)
- 1 Tool, 7/64 in. Allen Wrench (2021068)
- 1 Tool, 4 in. Jacknut Wrench (2053373)

TSW-770/1070-MUMK-B Only

- 1 Corner Cap, Mullion, Front Mount, Black (4530126)
- 1 Mount, Mullion, with Magnets, Black (4529894)
- 1 Panel Cover, Mullion, Black (2055338)

TSW-770/1070-MUMK-W Only

- 1 Corner Cap, Mullion, Front Mount, White (4530125)
- 1 Mount, Mullion, with Magnets, White (4529941)
- 1 Panel Cover, Mullion, White (2055337)

Mullion Mount Kit for TSW-770 and TSW-1070



Install the TSW-770/1070-MUMK

The TSW-770/1070-MUMK can be installed in one of two configurations—side mount or front mount—using the appropriate mounting bracket. The installation procedures for both configurations are described in the sections that follow.

Side Mount Configuration

To install the TSW-770/1070-MUMK in a side mount configuration:

1. Drill two 1/3 in. (8.4 mm) holes and one 1/2 in. (13 mm) center hole in the desired location on the mullion using the included cutout template.

NOTES:

- For a completely flush installation, align the front edge of the mullion mount with the front of the mullion as a reference.
- The mullion must have a minimum mounting depth of 3/4 in. (19 mm). If the mullion has a shallower depth, contact Crestron for custom installation instructions.
- The chosen mounting location must provide sufficient length to run the cables from their sources through the mullion and up to the touch screen.

2. Thread the 6-32 x 1 in. truss head screw through the opening in the included jacknut wrench and into one of the jacknuts, then align the jacknut with one of the 1/3 in. (8.4 mm) holes drilled into the mullion.

NOTE: Ensure that the jacknut wrench is oriented correctly. Refer to the machined instructional text on the jacknut wrench.

3. Rotate the jacknut wrench clockwise until the jacknut is secured to the mullion.

4. Remove the screw and wrench from the installed jacknut and repeat steps 2 and 3 for the other jacknut.

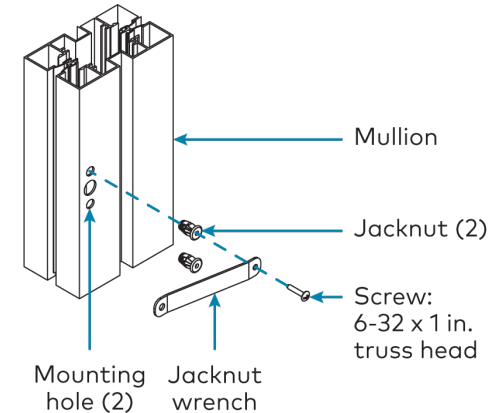

5. Run the Ethernet cable and USB cables (if used) up through the mullion and out of the center routing hole.
6. Attach the side mount bracket to the jacknuts using the included 6-32 x 1/2 in. flat head screws.

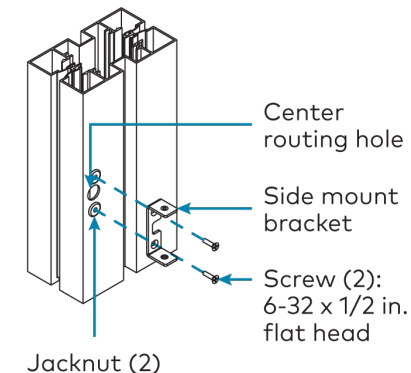

Mullion Mount Kit for TSW-770 and TSW-1070

7. Install the mullion mount:
 - a. Pull the two cover plates gently off of the top and bottom of the mullion mount to break the magnetic hold. Refer to the illustration below step 9 for cover plate locations.
 - b. Slide the mullion mount over the side mount bracket and route any cables out of the center hole in the mount.
 - c. Secure the mullion mount to the bracket using the included Allen wrench and the two 6-32 x 3/8 in. socket head screws.

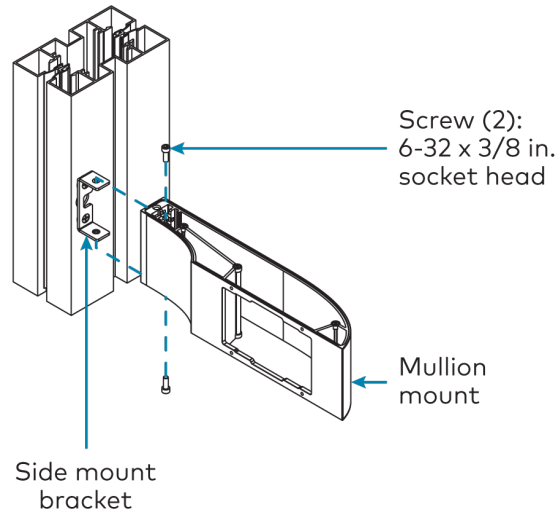

8. Align the TSW-770/TSW-1070 mounting bracket (included with touch screen) with the panel cover as shown in the illustration below, and then secure both to the mullion mount with the four 4-40 x 1/2 in. undercut head screws.

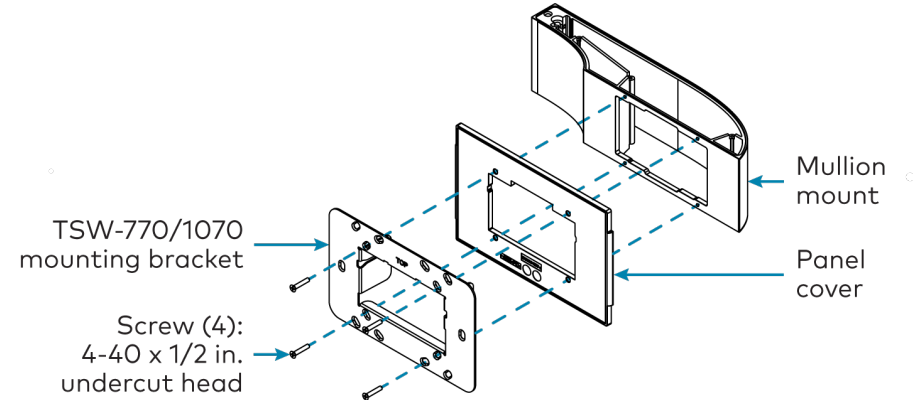

Mullion Mount Kit for TSW-770 and TSW-1070

If the TSW-770-LB or TSW-1070-LB light bar will be used in this installation, use the four provided 4-40 x 3/4 in. screws instead of the 4-40 x 1/2 in. screws. The light bar should be placed in between the TSW-770/1070 mounting bracket and the panel cover as shown in the illustration below.

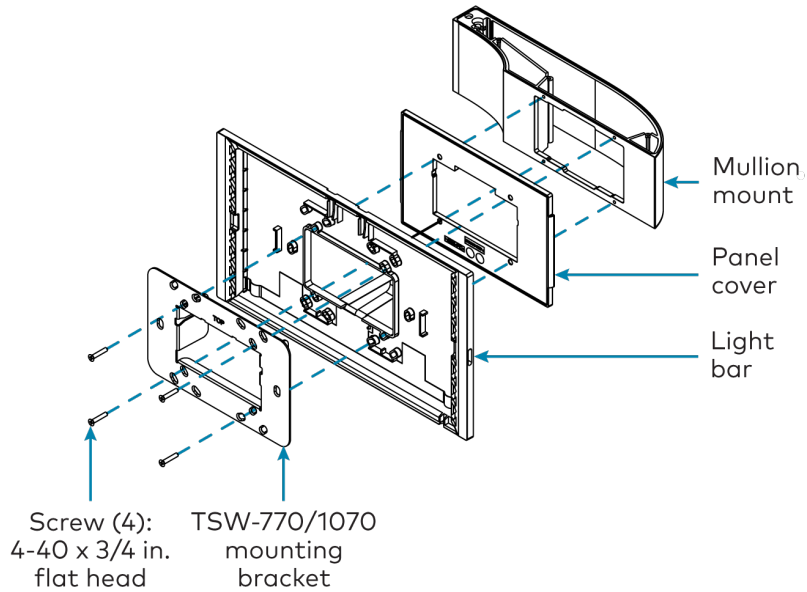

9. Reattach the two fitted cover plates on the top and bottom of the mullion mount so that the cover plates magnetically snap into place against the exposed screws.

NOTE: Ensure the cover plates are seated flush once installed in the mullion mount.

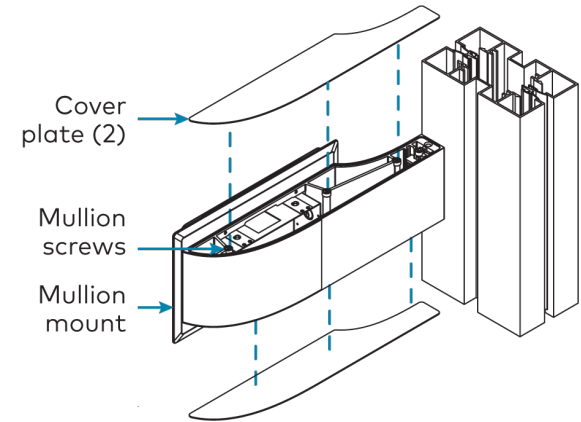

Mullion Mount Kit for TSW-770 and TSW-1070

Front Mount Configuration

To install the TSW-770/1070-MUMK in a front mount configuration:

1. Drill two 1/3 in. (8.4 mm) holes and one 1/2 in. (13 mm) center hole in the desired location on the mullion using the included cutout template.

NOTES:

- The mullion must have a minimum mounting depth of 3/4 in. (19 mm). If the mullion has a shallower depth, contact Crestron for custom installation instructions.
- The chosen mounting location must provide sufficient length to run the cables from their sources through the mullion and up to the touch screen.

2. Thread the 6-32 x 1 in. truss head screw through the opening in the included jacknut wrench and into one of the jacknuts, then align the jacknut with one of the 1/3 in. (8.4 mm) holes drilled into the mullion.

NOTE: Ensure that the jacknut wrench is oriented correctly. Refer to the machined instructional text on the jacknut wrench.

3. Rotate the jacknut wrench clockwise until the jacknut is secured to the mullion.

4. Remove the screw and wrench from the installed jacknut and repeat steps 2 and 3 for the other jacknut.

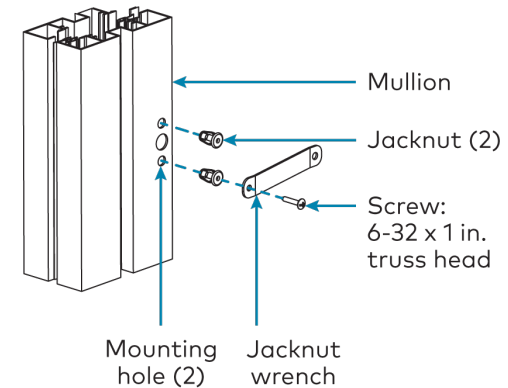

5. Run the Ethernet cable and USB cables (if used) up through the mullion and out of the center routing hole.
6. Attach the front mount bracket to the jacknuts using the included 6-32 x 1/2 in. pan head screws.

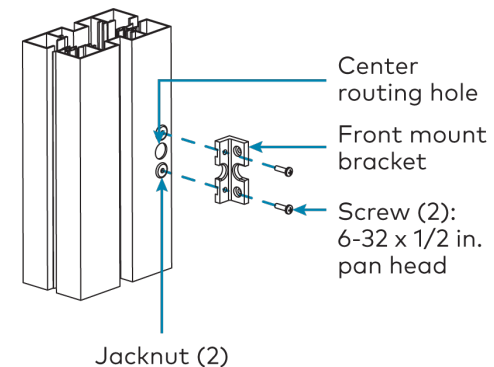

Mullion Mount Kit for TSW-770 and TSW-1070

7. Install the mullion mount:
 - a. Pull the two cover plates gently off of the top and bottom of the mullion mount to break the magnetic hold. Refer to the illustration below step 10 for cover plate locations.
 - b. Route any cables out of the center hole in the mount.
 - c. Secure the mullion mount to the bracket using the included the two 6-32 x 7/16 in. pan head screws with the two #06 spacers.

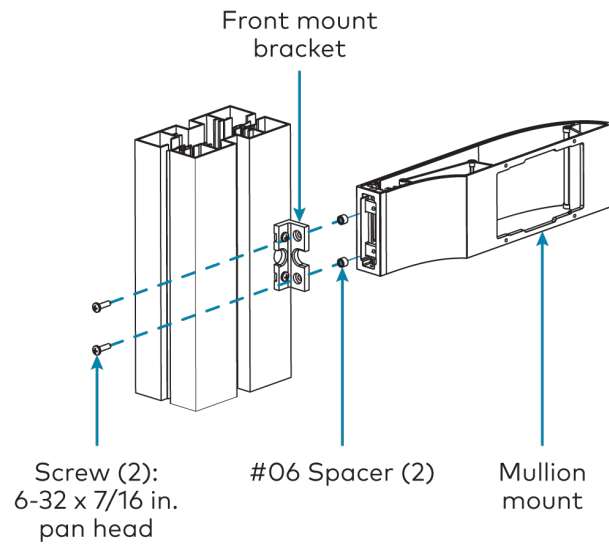

8. Align the TSW-770/TSW-1070 mounting bracket (included with touch screen) with the panel cover as shown in the illustration below, and then secure both to the mullion mount with the four 4-40 x 1/2 in. undercut head screws.

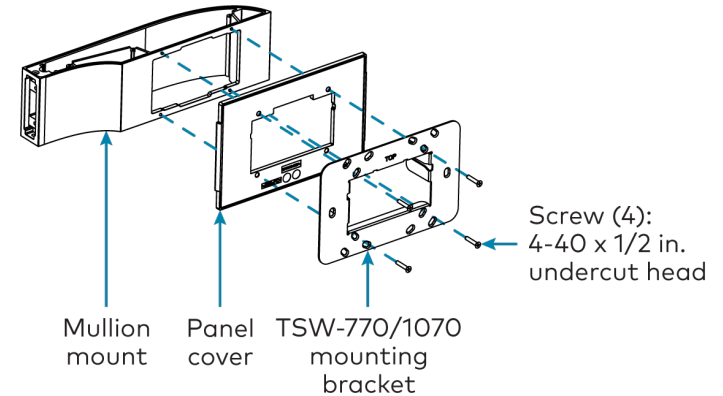

Mullion Mount Kit for TSW-770 and TSW-1070

If the TSW-770-LB or TSW-1070-LB light bar will be used in this installation, use the four provided 4-40 x 3/4 in. screws instead of the 4-40 x 1/2 in. screws. The light bar should be placed in between the TSW-770/1070 mounting bracket and the panel cover as shown in the illustration below.

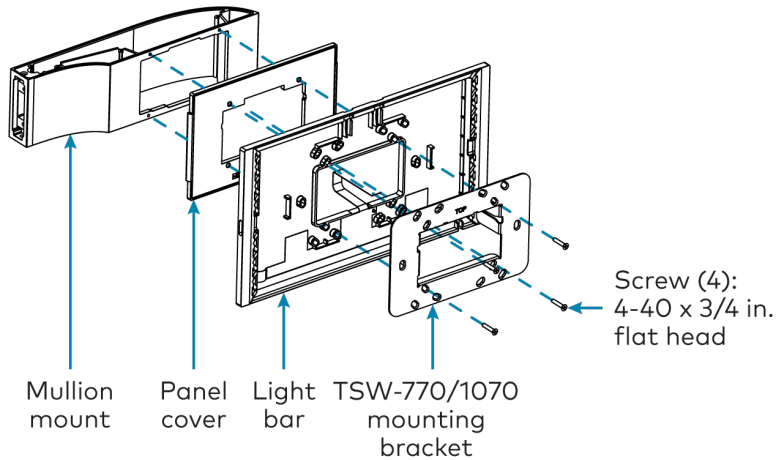

- Slide the front corner cap over the exposed edges of the front mount bracket as shown in the illustration below, and secure it to the mullion using the two 4-40 x 1/4 in. flat head screws.

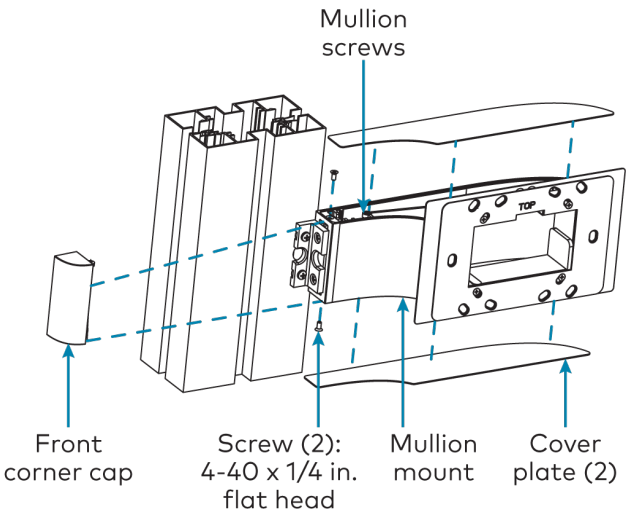

- Reattach the two fitted cover plates on the top and bottom of the mullion mount so that the cover plates magnetically snap into place against the exposed screws.

NOTE: Ensure the cover plates are seated flush once installed in the mullion mount.

Mullion Mount Kit for TSW-770 and TSW-1070

Attach the Touch Screen

1. Connect all cables to the rear of the touch screen.
2. Push the touch screen gently into the mounting bracket until the rear of the touch screen snaps into place inside the mounting bracket.
3. If a TSW-770-LB or TSW-1070-LB light bar was installed with the MUMK, ensure that the light bar flex circuit did not pop one of the cover plates off of the mullion mount. If this has occurred, tuck the flex circuit back into the mullion mount and then reinstall the cover plate.



Visit the Product Page

Scan the QR code to visit the product page.

TSW-770/1070-MUMK



www.crestron.com/model/6511260

Additional Information

Original Instructions

The U.S. English version of this document is the original instructions. All other languages are a translation of the original instructions.

The product warranty can be found at www.crestron.com/warranty.

The specific patents that cover Crestron products are listed at www.crestron.com/legal/patents.

Certain Crestron products contain open source software. For specific information, visit www.crestron.com/opensource.

Crestron and the Crestron logo are either trademarks or registered trademarks of Crestron Electronics, Inc. in the United States and/or other countries. Other trademarks, registered trademarks, and trade names may be used in this document to refer to either the entities claiming the marks and names or their products. Crestron disclaims any proprietary interest in the marks and names of others. Crestron is not responsible for errors in typography or photography.

©2021 Crestron Electronics, Inc.

Doc. 8653D

08/09/21