

## Introduction

Crestron® CAEN-MLO Series automation enclosures provide a professional centralized dimming solution for residential and commercial applications. CAEN-MLO enclosures are available in three sizes and allow for surface and flush wall-mount installation. They provide a manageable installation with abundant provisions for wire termination and electrical knockouts.

### Features and Functions

- Houses Crestron lighting modules, terminal blocks, automation control system, circuit breaker panel, up to 80 controlled circuits, up to 20 circuit breakers, dead front, and third-party products
- Split phase (120/240 Vac) or three phase (120/208 Vac) main lugs at 50/60 Hz phase-to-neutral and 225 A max
- 16-gauge galvanized steel box, invertible
- Flush or surface mount installation
- Vented front cover with hinged breaker access door
- Eaton® CH circuit breakers (20 A, single-pole, 120 V, 10 kAIC, and 4 AWG max wire gauge): CLB-120-20A, CLB-120-20A-AFCI, and CLB-120-20A-GFCI (all sold separately)

### Specifications

DIMENSIONS <sup>1</sup>	CAEN-5x2-MLO-120/2P	CAEN-5x2-MLO-120/3P	CAEN-5x1-MLO-120/2P	CAEN-5x1-MLO-120/3P	CAEN-3x1-MLO-120/2P
H1	62 (1575)	62 (1575)	62 (1575)	62 (1575)	38 7/8 (987)
H2	2 11/16 (68)	2 11/16 (68)	2 11/16 (68)	2 11/16 (68)	2 1/8 (53)
H3	56 (1422)	56 (1422)	56 (1422)	56 (1422)	34 (863)
H4	7 5/8 (194)	7 5/8 (194)	7 5/8 (194)	7 5/8 (194)	6 (153)
W1	26 1/2 (673)	26 1/2 (673)	15 3/8 (390)	15 3/8 (390)	15 3/8 (390)
W2	25 1/2 (647)	25 1/2 (647)	14 3/8 (365)	14 3/8 (365)	14 3/8 (365)
W3	2 1/2 (63)	2 1/2 (63)	1 3/4 (44)	1 3/4 (44)	1 3/4 (44)
W4	20 1/2 (520)	20 1/2 (520)	10 7/8 (276)	10 7/8 (276)	10 7/8 (276)
W5 <sup>2</sup>	20 1/2 (520)	20 1/2 (520)	9 7/8 (250)	9 7/8 (250)	9 7/8 (250)
W6	2 1/2 (63)	2 1/2 (63)	2 3/4 (69)	2 3/4 (69)	2 3/4 (69)
D1	4 1/8 (104)	4 1/8 (104)	4 1/8 (104)	4 1/8 (104)	4 1/8 (104)
Cover Thickness <sup>3</sup>	1/16 (1)	1/16 (1)	1/16 (1)	1/16 (1)	1/16 (1)
Cover Height	62 3/4 (1593)	62 3/4 (1593)	62 3/4 (1593)	62 3/4 (1593)	39 5/8 (1006)
Cover Width	27 1/4 (692)	27 1/4 (692)	16 1/8 (409)	16 1/8 (409)	16 1/8 (409)
Weight (empty) <sup>4</sup>	73 (33.2)	73 (33.2)	50 (22.7)	50 (22.7)	33 (15)
Maximum Weight (filled)	141 (64)	141 (64)	88 (40)	88 (40)	53 (24.1)

CAEN-MLO Overall Dimensions (Front and Side Views)

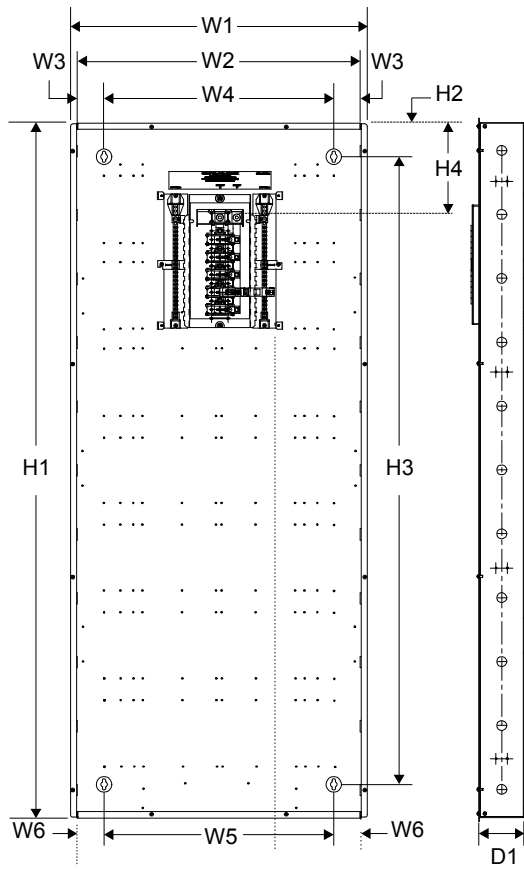

1. Length is specified in inches and millimeters (in parentheses). Weight is specified in pounds and kilograms (in parentheses).
2. The lower keyholes are not symmetrically spaced within single-wide enclosures.
3. Thickness does not include breaker access door. The breaker access door extends 11/16 inches (18 millimeters) above the cover on all cabinets.
4. Weight (empty) is the weight of an empty enclosure with cover.

**NOTE:** Double-winged mounting holes are located on the enclosure, which allow inverted mounting in flood prone areas without violating breaker height standards.



**Regulatory Compliance**

This product is Listed to applicable UL Standards and requirements by Underwriters Laboratories Inc.



As of the date of manufacture, the CAEN-MLO Series has been tested and found to comply with specifications for CE marking.

**Conformité Réglementaire**

Ce produit est homologué selon les normes et les exigences UL applicables par Underwriters Laboratories Inc.

**Federal Communications Commission (FCC) Compliance Statement**

These devices comply with part 15 of the FCC Rules. Operation is subject to the following conditions: (1) These devices may not cause harmful interference and (2) these devices must accept any interference received, including interference that may cause undesired operation.

**CAUTION:** Changes or modifications not expressly approved by the manufacturer responsible for compliance could void the user's authority to operate the equipment.

**NOTE:** This equipment has been tested and found to comply with the limits for a Class B digital device, pursuant to part 15 of the FCC Rules. These limits are designed to provide reasonable protection against harmful interference in a residential installation. This equipment generates, uses and can radiate radio frequency energy and, if not installed and used in accordance with the instructions, may cause harmful interference to radio communications. However, there is no guarantee that interference will not occur in a particular installation. If this equipment does cause harmful interference to radio or television reception, which can be determined by turning the equipment off and on, the user is encouraged to try to correct the interference by one or more of the following measures:

- Reorient or relocate the receiving antenna
- Increase the separation between the equipment and receiver
- Connect the equipment into an outlet on a circuit different from that to which the receiver is connected
- Consult the dealer or an experienced radio/TV technician for help

---

**Industry Canada (IC) Compliance Statement**

**Industrie Canada (IC) Déclaration de conformité**

CAN ICES-3(B)/NMB-3(B)

---

## Installation

The enclosure must be mounted by a licensed electrician in accordance with all national and local codes. Refer to the table on the first page for the weight of a fully loaded enclosure.

When choosing components to place in the enclosure, refer to the “Specifications” table to ensure that the maximum weight capacity is not exceeded. Each module’s product page on the Crestron website lists the module’s weight.

CLT terminal blocks must be mounted using the screw holes shown in the “Mounting Details” diagrams on page 4.

**CAUTION:** These enclosures house equipment that needs to be air-cooled. Therefore, mount in a well-ventilated area. The ambient temperature range should be 32°F to 104°F (0°C to 40°C). The relative humidity should range from 10% to 90% (non-condensing). Furthermore, allow adequate clearance in front of the vented cover for servicing and ventilation.

**CAUTION:** When installing modules in the enclosure, start at the bottommost module space. If the top module space (or top two module spaces for a double-wide) is filled, each feed into the top module must be derated by 25% so that each feed carries no more than 12 A.

**NOTE:** Enclosures are intended for indoor use only.

**NOTE:** When flush mounting, 5/8 in (16 mm) drywall is preferred.

## Wiring

**CAUTION:** All power feeds must be protected by a 15 or 20 A ground fault, arc fault, or thermal magnetic circuit breakers (sold separately).

**NOTE:** Use copper conductors only – rated 75°C.

**NOTE:** All wiring must be installed in accordance with all national and local electrical codes.

**NOTE:** Six snap bushings are supplied. If required, insert into knockouts at the bottom and top of the enclosure to prevent damage to low voltage wiring.

Class 1 and Class 2 field wires must be kept separate. Refer to the illustrations on pages 4 and 5 showing single-wide and double-wide wiring details. Areas for high voltage (Class 1) wiring are along the top and side(s) of the unit. The lower area is for low voltage (Class 2) wiring.

Tighten all CLT terminal block screws and grounding terminal block screws to the torque specified in the “Wire Gauge and Torque Data” table in the next column.

**CAUTION:** Failure to properly tighten the screws may result in poor electrical connection and overheating of the terminals.

To wire the CAEN-MLO, insert breakers using the following procedure:

1. Align the neutral clip with the breaker slot.
2. Press firmly down on the back of the breaker to clip the breaker onto the neutral bar.
3. Rock the breaker forward and press firmly on the front of the breaker to attach the panel.

### Wire Gauge and Torque Data

	WIRE GAUGE (AWG)	TORQUE (in-lb)
CLT Terminal Blocks	22–10	9
Grounding Terminal Blocks	14–10	35
	8	40
Main Lugs	6–4	45
	5x1/5x2: 4/0 (max)	225
Neutral Lug (Slotted Screw)	3x1: 2/0 (max)	225
	4–2/0	50
Breakers	14–10	20
	8	25
	6–4	35

### Key – Typical Items in a CAEN-MLO Enclosure

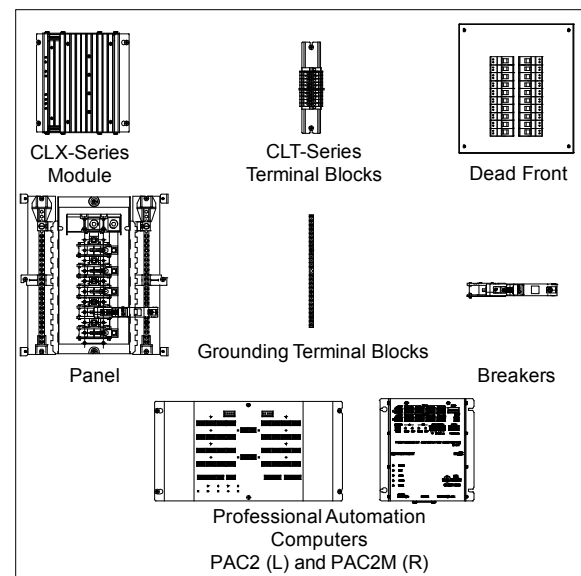

*Mounting Details – Double-Wide CAEN-MLO*

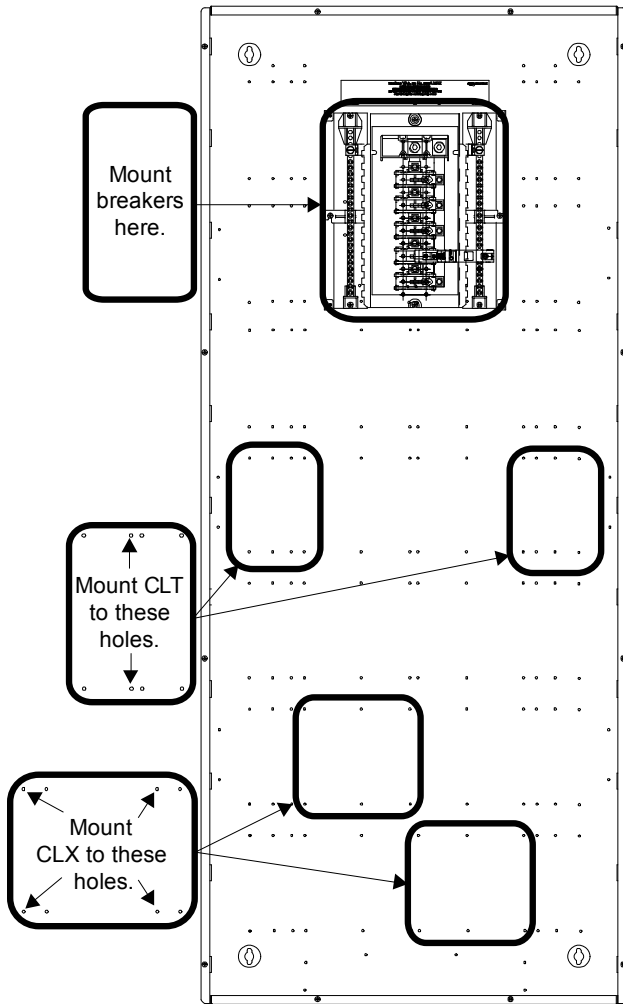

Mount breakers, CLT terminal blocks, and CLX modules to the holes shown.

*Mounting Details – Single-Wide CAEN-MLO*

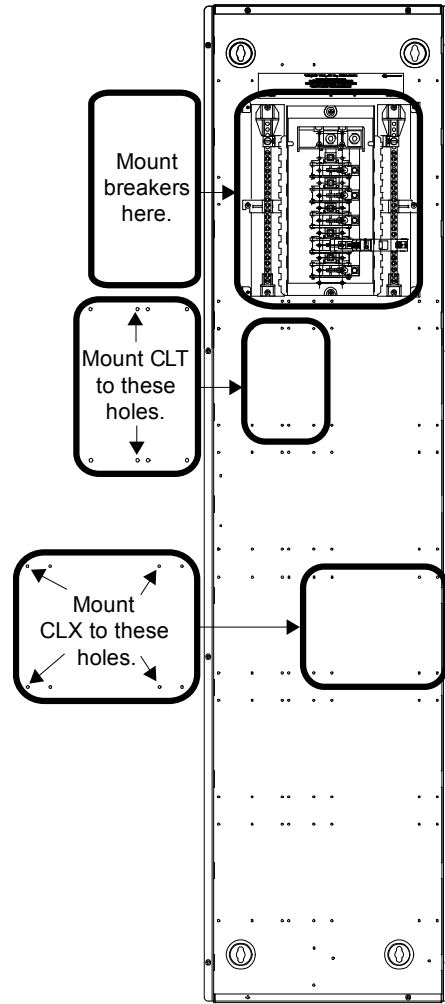

Mount breakers, CLT terminal blocks, and CLX modules to the holes shown.

*Wiring Details – CAEN-5X2-MLO-120/2P*

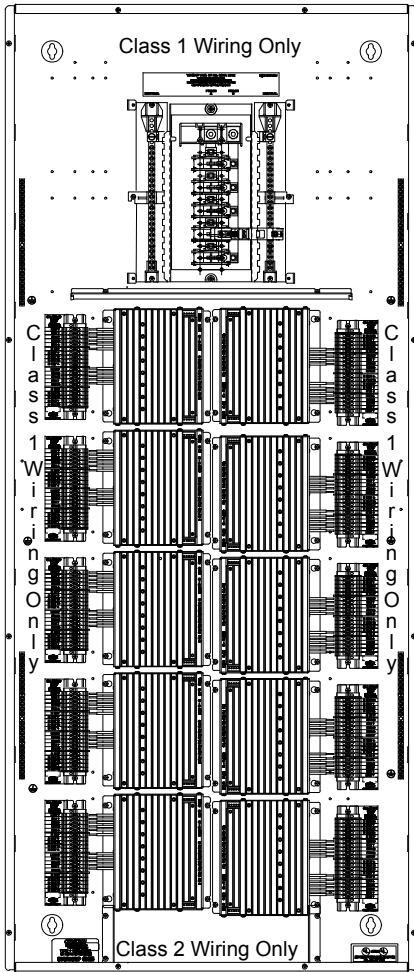

*Wiring Details – CAEN-5X1-MLO-120/2P*

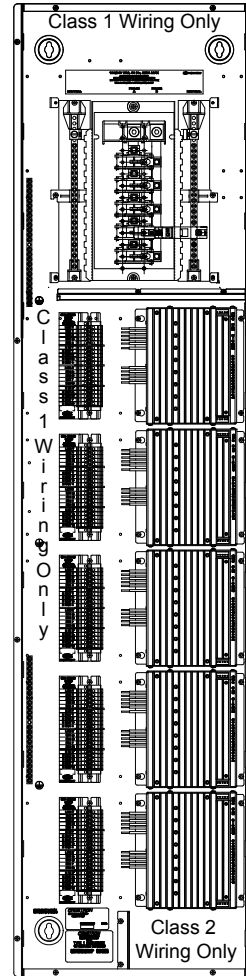

*Wiring Details – CAEN-3X1-MLO-120/2P*

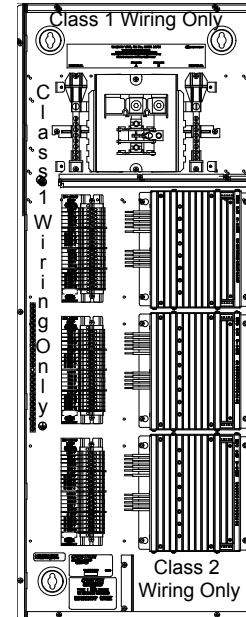

**WARNING: RISK OF SERIOUS PERSONAL INJURY.** This enclosure may include high voltage wires. Turn off power supply to the equipment before working inside, otherwise serious personal injury and damage to the device can result.

**CAUTION:** AFCI breakers must be wired with a single neutral wire per circuit. Shared neutrals across a multiwire circuit cause the AFCI breaker to trip due to built-in safety guards.

**CAUTION:** Ensure that all phases are balanced properly between circuits. Unbalanced phases can cause increased current in the neutral conductor, overheating, reduced efficiency, and wasted energy.

**NOTE:** An SCCR rating of 5 kA rms is defined for an empty enclosure, noted on the label included. Once populated with modules, the custom build sheet identifies a new SCCR rating for the enclosure and module unit.

**NOTE:** This equipment is designed and tested by Eaton Corporation, Inc. for use with Eaton type CH branch breakers only. Use of non-Eaton breakers may adversely affect user safety and impair reliability. Eaton disclaims all liability for damage, injury, or non-performance caused by the use or failure of non-Eaton breakers.

*Example Wiring Diagram*

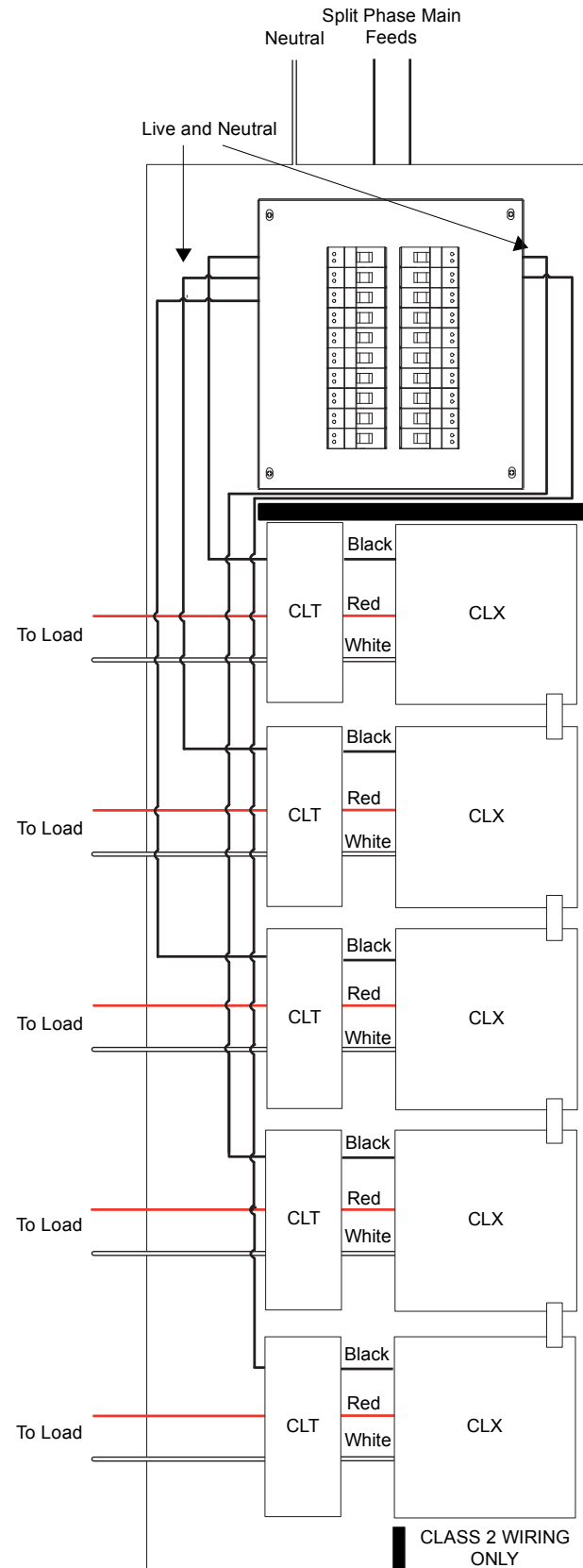

## Further Inquiries

To locate specific information or resolve questions after reviewing this guide, contact Crestron's True Blue Support at 1-888-CRESTRON [1-888-273-7876] or, for assistance within a particular geographic region, refer to the listing of Crestron worldwide offices at [www.crestron.com/offices](http://www.crestron.com/offices).

To post a question about Crestron products, log onto Crestron's Online Help at [www.crestron.com/onlinehelp](http://www.crestron.com/onlinehelp). First-time users must establish a user account to fully benefit from all available features.

---

## Future Updates

As Crestron improves functions, adds new features, and extends the capabilities of the CAEN-MLO Series, additional information may be made available as manual updates. These updates are solely electronic and serve as intermediary supplements prior to the release of a complete technical documentation revision.

Check the Crestron website periodically for manual update availability and its relevance. Updates are identified as an "Addendum" in the Download column.

The specific patents that cover Crestron products are listed at [patents.crestron.com](http://patents.crestron.com).

Crestron and the Crestron logo are trademarks or registered trademarks of Crestron Electronics, Inc. in the United States and/or other countries. Eaton is either a trademark or a registered trademark of Eaton Corporation, Inc. in the United States and/or other countries. UL and the UL logo are either trademarks or registered trademarks of Underwriters Laboratories, Inc. in the United States and/or other countries. Other trademarks, registered trademarks, and trade names may be used in this document to refer to either the entities claiming the marks and names or their products. Crestron disclaims any proprietary interest in the marks and names of others. *Crestron is not responsible for errors in typography or photography.*

This document was written by the Technical Publications department at Crestron.  
©2014 Crestron Electronics, Inc.

---

## Return and Warranty Policies

### Merchandise Returns / Repair Service

1. No merchandise may be returned for credit, exchange or service without prior authorization from Crestron. To obtain warranty service for Crestron products, contact an authorized Crestron dealer. Only authorized Crestron dealers may contact the factory and request an RMA (Return Merchandise Authorization) number. Enclose a note specifying the nature of the problem, name and phone number of contact person, RMA number and return address.
2. Products may be returned for credit, exchange or service with a Crestron Return Merchandise Authorization (RMA) number. Authorized returns must be shipped freight prepaid to Crestron, 6 Volvo Drive, Rockleigh, N.J. or its authorized subsidiaries, with RMA number clearly marked on the outside of all cartons. Shipments arriving freight collect or without an RMA number shall be subject to refusal. Crestron reserves the right in its sole and absolute discretion to charge a 15% restocking fee plus shipping costs on any products returned with an RMA.
3. Return freight charges following repair of items under warranty shall be paid by Crestron, shipping by standard ground carrier. In the event repairs are found to be non-warranty, return freight costs shall be paid by the purchaser.

### Crestron Limited Warranty

Crestron Electronics, Inc. warrants its products to be free from manufacturing defects in materials and workmanship under normal use for a period of three (3) years from the date of purchase from Crestron, with the following exceptions: disk drives and any other moving or rotating mechanical parts, pan/tilt heads and power supplies are covered for a period of one (1) year; touch screen display and overlay components are covered for 90 days; batteries and incandescent lamps are not covered.

This warranty extends to products purchased directly from Crestron or an authorized Crestron dealer. Purchasers should inquire of the dealer regarding the nature and extent of the dealer's warranty, if any.

Crestron shall not be liable to honor the terms of this warranty if the product has been used in any application other than that for which it was intended or if it has been subjected to misuse, accidental damage, modification or improper installation procedures. Furthermore, this warranty does not cover any product that has had the serial number altered, defaced or removed.

This warranty shall be the sole and exclusive remedy to the original purchaser. In no event shall Crestron be liable for incidental or consequential damages of any kind (property or economic damages inclusive) arising from the sale or use of this equipment. Crestron is not liable for any claim made by a third party or made by the purchaser for a third party.

Crestron shall, at its option, repair or replace any product found defective, without charge for parts or labor. Repaired or replaced equipment and parts supplied under this warranty shall be covered only by the unexpired portion of the warranty.

Except as expressly set forth in this warranty, Crestron makes no other warranties, expressed or implied, nor authorizes any other party to offer any warranty, including any implied warranties of merchantability or fitness for a particular purpose. Any implied warranties that may be imposed by law are limited to the terms of this limited warranty. This warranty statement supersedes all previous warranties.