

Crestron **TMK-9L & WMKT-9L**
Trim Ring Mount Kits

Installation Guide



This document was prepared and written by the Technical Documentation department at:



Crestron Electronics, Inc.
15 Volvo Drive
Rockleigh, NJ 07647
1-888-CRESTRON

Regulatory Compliance

As of the date of manufacture, the TMK-9L & WMKT-9L have been tested and found to comply with specifications for CE marking and standards per EMC and Radiocommunications Compliance Labelling.



Contents

Trim Ring Mount Kits: TMK-9L & WMKT-9L	1
Description.....	1
Setup.....	4
Supplied Hardware.....	4
Installation.....	4
Resources.....	9
Reference Documents.....	9
Further Inquiries.....	9
Future Updates.....	9
Return and Warranty Policies.....	10
Merchandise Returns / Repair Service.....	10
CRESTRON Limited Warranty.....	10

Trim Ring Mount Kits: TMK-9L & WMKT-9L

Description

Trim Ring Mount Kits are the preferred method of mounting the Crestron Isys[®] TPMC-9L 9” Wall Mount Touchpanel when a finished appearance within a neatly trimmed cutout is required. This application is perfect for wallpapering.

NOTE: If mounted into a material other than drywall (for example, wood lectern, concrete or rock) use the cutout template, available in the post-construction kit WMKT-9L. For concrete and rock mounting material, allow for proper ventilation before mounting the touchpanel.

There are two Trim Ring Mount Kits. The TMK-9L is a pre-construction accessory. Pre-construction refers to framed walls prior to hanging drywall. This accessory must be used with either the Pre-Construction Wall Mount Kit (PMK-9L) or Wall Mount Back Box (BB-9L), both sold separately.

The WMKT-9L is a post construction kit. Post-construction refers to framed walls with drywall hung. This accessory is designed with a mounting plate so it can be placed anywhere on a wall without the support of a stud. The mounting plate is also ideal for installing the touchpanel in a lectern.

NOTE: If necessary, consult the latest version of the TPMC-9L Operations & Installation Guide (Doc. 7030) for a complete list of mounting options. The document is available from the Crestron[®] website (www.crestron.com/manuals).

The dimensions of the TMK-9L and WMKT-9L are shown in the following illustrations.

TMK-9L Trim Ring Overall Dimensions

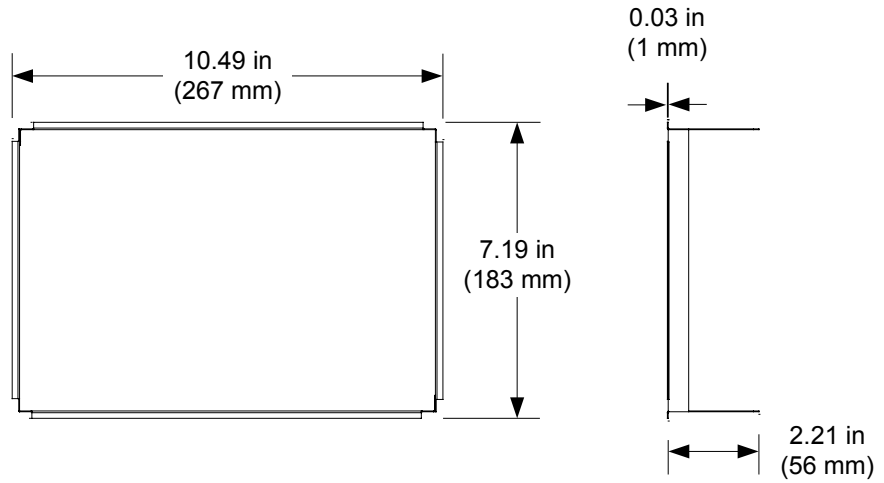

WMKT-9L Mounting Plate Overall Dimensions

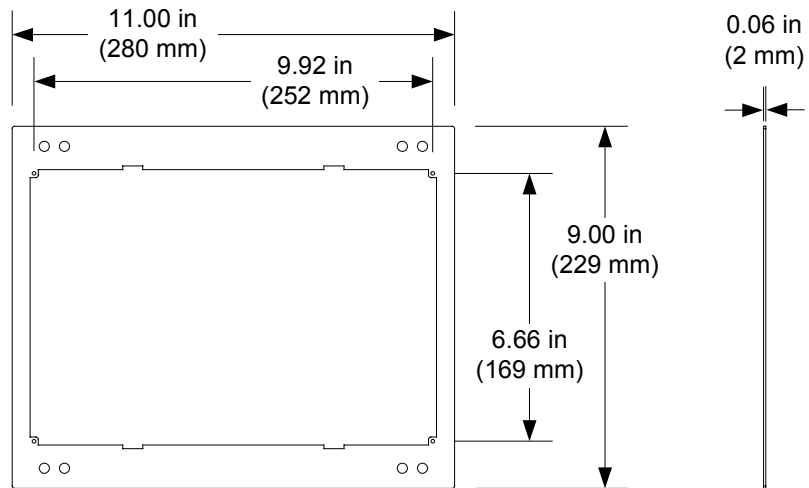

Drywall Cutout Template and Dimensions, 1 of 2 (Supplied with WMKT-9L Only)

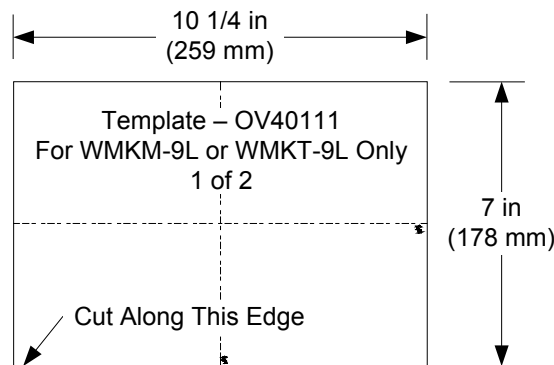

Drywall Cutout Template and Dimensions, 2 of 2 (Supplied with WMKT-9L Only)

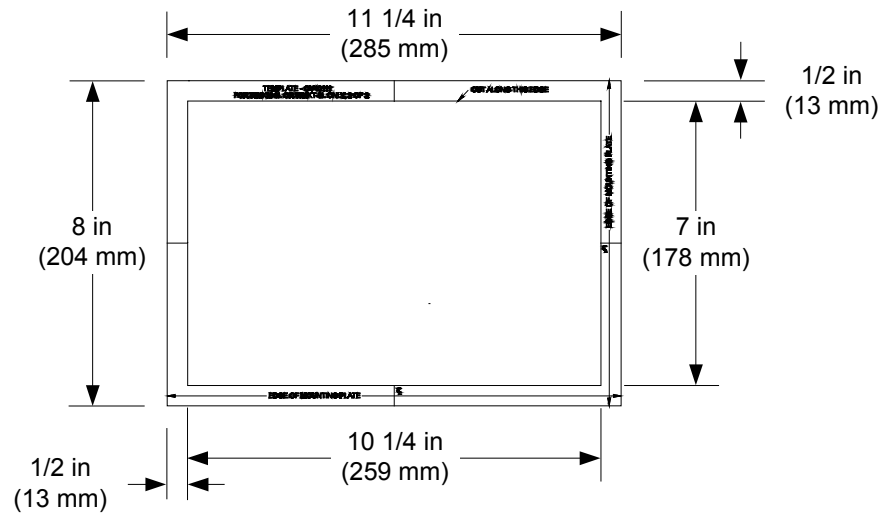

Setup

Supplied Hardware

The TMK-9L consists of a metal trim ring that attaches to the BB-9L or PMK-9L. The WMKT-9L consists of the trim ring found in the TMK-9L as well as a mounting plate.

The mounting plate provides the necessary support for installation in a wall, lectern, podium or similar flat surface. Two overlay cutout templates (4511894) are supplied. One is in the shape of the required opening; the other is similar to a frame, with the inner area of the frame the shape of the required opening. (Refer to the illustrations on pages 2 and 3). Use the template that is most convenient.

The hardware supplied with the TMK-9L and WMKT-9L is listed in the following table.

Supplied Hardware for the TMK-9L and WMKT-9L

DESCRIPTION	PART NUMBER	QUANTITY
Metal Plate, Ridge (Trim Ring)	2028253	1
Metal, Plate, Mounting (WMKT-9L only)	2028254	1
Screw, #04-40 x 1-1/2", Pan, Phil (WMKT-9L only)	2007190	4
Overlay, Template, Wall Cutout (WMKT-9L only)	4511894	1

Installation

This section provides an installation procedure for each Trim Ring Mount Kit. The "TMK-9L Procedure" starts below and the "WMKT-9L Procedure" starts on page 6. Be sure to review each procedure before starting.

TMK-9L Procedure

This section provides the necessary steps for the assembly of the TMK-9L with either the BB-9L or PMK-9L (both sold separately). It is assumed the BB-9L or PMK-9L has been secured to the stud according to the instructions in the latest revisions of their Installation Guides (Doc. 7031 and Doc. 7032 respectively). It is also assumed that drywall is in place and a cutout is made in the drywall for touchpanel installation.

Complete the steps in the order provided. The only tool required and not supplied is a level.

CAUTION: Allow an air gap of at least 12 inches (305 mm) in the wall cavity above and below the touchpanel for heat dissipation.

NOTE: The TMK-9L has been optimized for mounting in 5/8" (15 mm) drywall. You may use 1/2" – 1" (13 mm – 25 mm) without issue. Thinner or thicker drywall will cause issues with installation.

NOTE: The illustrations in this procedure show the installation of the TMK-9L with the PMK-9L. Even though the illustrations only show the PMK-9L, the procedure is identical for the BB-9L.

NOTE: When installing into the PMK-9L, verify the 18 AWG bus wire securing the cables for the touchpanel remains attached.

1. Verify the rectangular cutout in the drywall is as level as possible.
2. Insert the symmetrical trim ring into the opening, as shown in the following illustration.

Insert Trim Ring into Opening

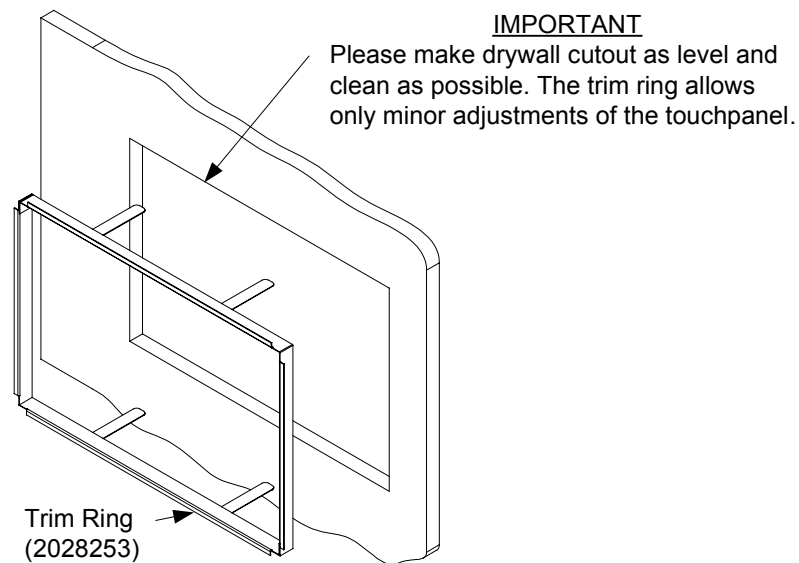

NOTE: The required PMK-9L or BB-9L is not shown.

3. When the trim ring is in position, bend the top two flanges of the ring upward and the bottom two flanges downward.
 - If mounting into the PMK-9L, bend the flanges approximately 90 degrees.
 - If mounting into the BB-9L, bend the flanges back as far as they can go.
4. Run the necessary cables for the touchpanel and secure them behind the drywall.
5. The TPMC-9L can be installed using the four tapped holes in the PMK-9L or BB-9L. Refer to the latest revision of the TPMC-9L Operations & Installation Guide (Doc. 7030) for details. Refer also to the comprehensive illustration below.

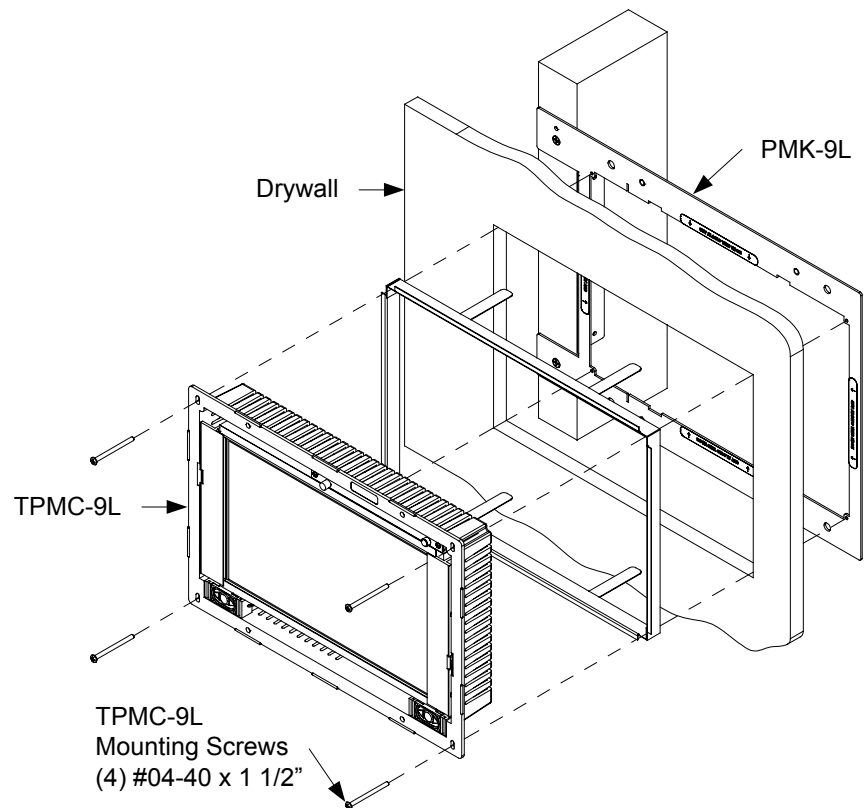
Touchpanel Mounting Using TMK-9L (Exploded View)**WMKT-9L Procedure**

This section provides the necessary steps for installation of the WMKT-9L into a wall. Review the procedure and complete the steps in the order provided. The only tools or materials required and not supplied are a drywall saw or equivalent and a level.

CAUTION: Allow an air gap of at least 12 inches (305 mm) in the wall cavity above and below the touchpanel for heat dissipation.

NOTE: The WMKT-9L has been optimized for mounting in 5/8" (15 mm) drywall. You may use 1/2" – 1" (13 mm – 25 mm) without issue. Thinner or thicker drywall will cause issues with installation.

1. Locate an area on the wall that is free of miscellaneous wiring and studs.
2. Make a small hole near the middle of the designated site and verify the location is suitable.

NOTE: Make the cutout as level and smooth as possible. The mounting plate allows for only minor leveling adjustments. If a larger cutout is made accidentally, consider purchasing the Crestron Mud Mount Kit, MMK-9L. Together with the mounting plate supplied with the WMKT-9L, it provides a cost effective means of correction. Essentially, the combination of these two kits makes up the Crestron Mud Mount Kit for the wall, WMKM-9L. Simply follow the "WMKM-9L Procedure" in the latest version of the Mud Mount Kits Installation Guide (Doc. 7033).

3. Use an appropriate saw and the provided cutout template to produce an accurate and level cutout in the mounting surface.
4. Insert the trim ring into the opening, as shown in the illustration below.

Insert Trim Ring into Opening

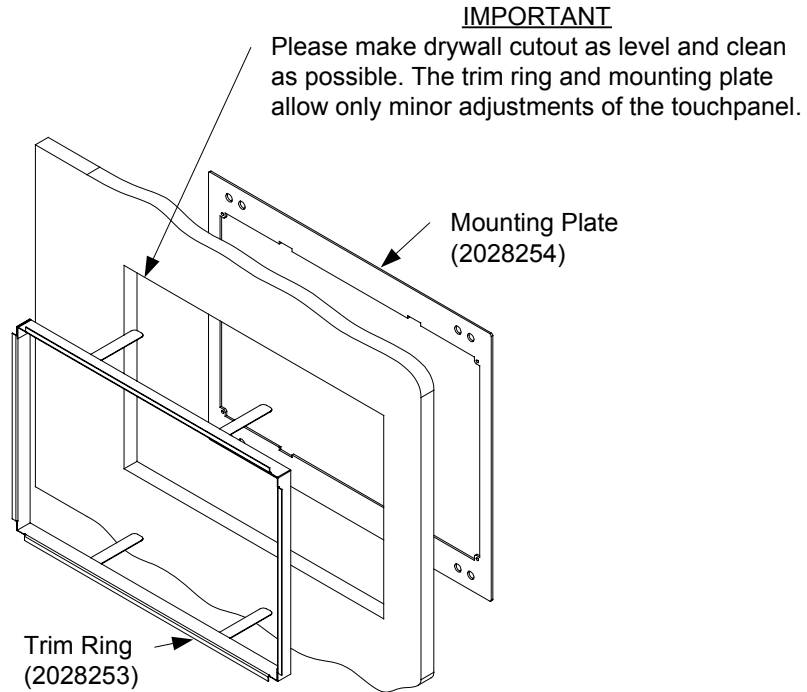

5. Carefully pass the mounting plate through the opening and hold it against the interior of the mounting surface.
6. When the mounting plate is in position, bend the top two flanges of the trim ring upward (approximately 90 degrees) and the bottom two flanges downward (approximately 90 degrees). Refer to the illustration on the following page.

NOTE: The mounting plate will have a slight play. This is normal and allows for minor adjustments to the touchpanel during installation.

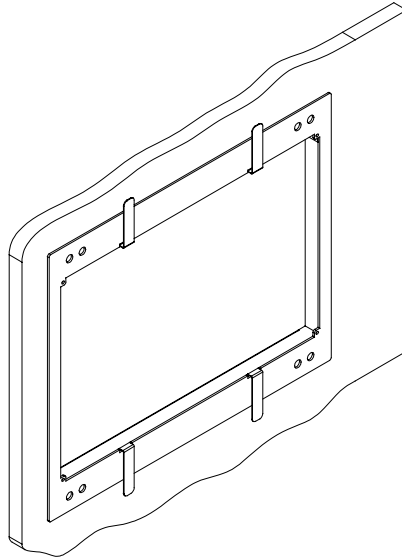
Bend Flanges

7. Run the necessary cables for the touchpanel and secure them behind the mounting surface.
8. The TPMC-9L can be installed using the four tapped holes in the PMK-9L or BB-9L. Refer to the latest revision of the TPMC-9L Operations & Installation Guide (Doc. 7030) for details. Refer also to the comprehensive illustration below.

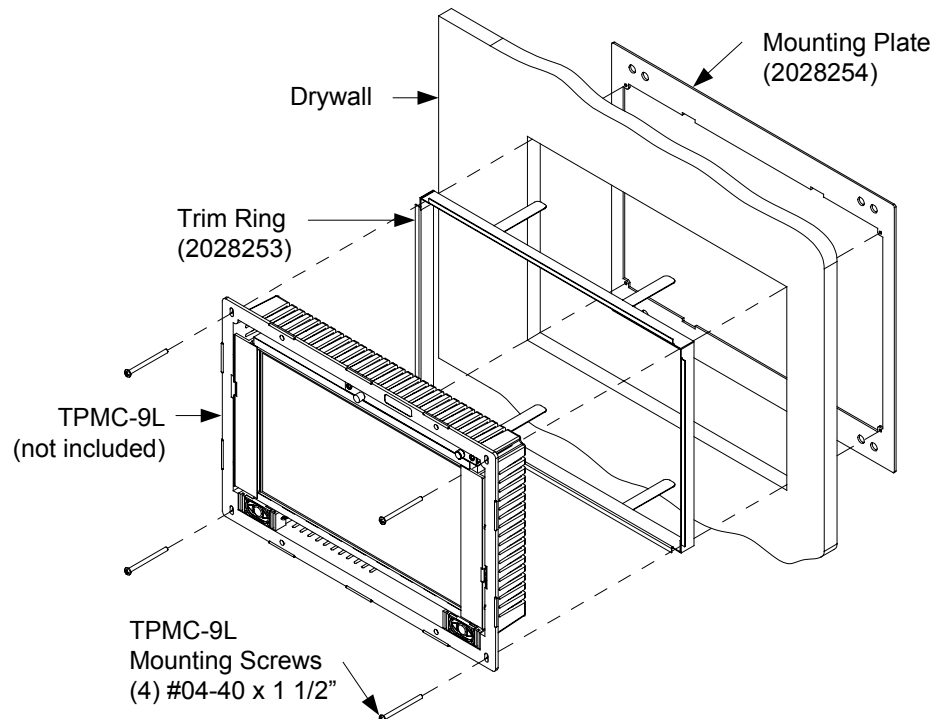
Touchpanel Mounting Using WMKT-9L (Exploded View)

Resources

Reference Documents

The latest version of all documents mentioned within the guide can be obtained from the Crestron website (www.crestron.com/manuals). This link will provide a list of product manuals arranged in alphabetical order by model number.

List of Related Reference Documents

DOCUMENT TITLE
BB-9L Pre-Construction Wall Mount Back Box
MMK-9L & WMKT-9L Mud Mount Kits
PMK-9L Pre-Construction Wall Mount Kit
TPMC-9L 9" Wall Mount Touchpanel

Further Inquiries

If you cannot locate specific information or have questions after reviewing this guide, please take advantage of Crestron's award winning customer service team by calling Crestron at 1-888-CRESTRON [1-888-273-7876].

You can also log onto the online help section of the Crestron website (www.crestron.com/onlinehelp) to ask questions about Crestron products. First-time users will need to establish a user account to fully benefit from all available features.

Future Updates

As Crestron improves functions, adds new features and extends the capabilities of the TMK-9L and WMKT-9L, additional information may be made available as manual updates. These updates are solely electronic and serve as intermediary supplements prior to the release of a complete technical documentation revision.

Check the Crestron website periodically for manual update availability and its relevance. Updates are identified as an “Addendum” in the Download column.

Return and Warranty Policies

Merchandise Returns / Repair Service

1. No merchandise may be returned for credit, exchange or service without prior authorization from CRESTRON. To obtain warranty service for CRESTRON products, contact an authorized CRESTRON dealer. Only authorized CRESTRON dealers may contact the factory and request an RMA (Return Merchandise Authorization) number. Enclose a note specifying the nature of the problem, name and phone number of contact person, RMA number and return address.
2. Products may be returned for credit, exchange or service with a CRESTRON Return Merchandise Authorization (RMA) number. Authorized returns must be shipped freight prepaid to CRESTRON, 6 Volvo Drive, Rockleigh, N.J. or its authorized subsidiaries, with RMA number clearly marked on the outside of all cartons. Shipments arriving freight collect or without an RMA number shall be subject to refusal. CRESTRON reserves the right in its sole and absolute discretion to charge a 15% restocking fee plus shipping costs on any products returned with an RMA.
3. Return freight charges following repair of items under warranty shall be paid by CRESTRON, shipping by standard ground carrier. In the event repairs are found to be non-warranty, return freight costs shall be paid by the purchaser.

CRESTRON Limited Warranty

CRESTRON ELECTRONICS, Inc. warrants its products to be free from manufacturing defects in materials and workmanship under normal use for a period of three (3) years from the date of purchase from CRESTRON, with the following exceptions: disk drives and any other moving or rotating mechanical parts, pan/tilt heads and power supplies are covered for a period of one (1) year; touchscreen display and overlay components are covered for 90 days; batteries and incandescent lamps are not covered.

This warranty extends to products purchased directly from CRESTRON or an authorized CRESTRON dealer. Purchasers should inquire of the dealer regarding the nature and extent of the dealer's warranty, if any.

CRESTRON shall not be liable to honor the terms of this warranty if the product has been used in any application other than that for which it was intended or if it has been subjected to misuse, accidental damage, modification or improper installation procedures. Furthermore, this warranty does not cover any product that has had the serial number altered, defaced or removed.

This warranty shall be the sole and exclusive remedy to the original purchaser. In no event shall CRESTRON be liable for incidental or consequential damages of any kind (property or economic damages inclusive) arising from the sale or use of this equipment. CRESTRON is not liable for any claim made by a third party or made by the purchaser for a third party.

CRESTRON shall, at its option, repair or replace any product found defective, without charge for parts or labor. Repaired or replaced equipment and parts supplied under this warranty shall be covered only by the unexpired portion of the warranty.

Except as expressly set forth in this warranty, CRESTRON makes no other warranties, expressed or implied, nor authorizes any other party to offer any warranty, including any implied warranties of merchantability or fitness for a particular purpose. Any implied warranties that may be imposed by law are limited to the terms of this limited warranty. This warranty statement supersedes all previous warranties.

Trademark Information

All brand names, product names and trademarks are the sole property of their respective owners. Windows is a registered trademark of Microsoft Corporation. Windows 95/98/Me/XP/Vista/7 and Windows NT/2000 are trademarks of Microsoft Corporation.

This page is intentionally left blank.



Crestron Electronics, Inc.
15 Volvo Drive Rockleigh, NJ 07647
Tel: 888.CRESTRON
Fax: 201.767.7576
www.crestron.com

**Installation Guide – DOC. 7034A
(2028353)**

08.10

Specifications subject to
change without notice.