

Crestron **TPS-4500IMW**
Wall-Mounted Interface Module

Operations Guide



CRESTRON

This document was prepared and written by the Technical Documentation department at:



Crestron Electronics, Inc.
15 Volvo Drive
Rockleigh, NJ 07647
1-888-CRESTRON

Contents

Wall-Mounted Interface Module: TPS-4500IMW	1
Description.....	1
Functional Description	1
Physical Description.....	1
I/O Ports	1
Leading Specifications.....	4
Setup.....	4
Network Wiring.....	4
Hardware Hookup	5
Problem Solving	9
Troubleshooting.....	9
Further Inquiries	9
Future Updates	10
Return and Warranty Policies.....	11
Merchandise Returns / Repair Service	11
CRESTRON Limited Warranty.....	11

Wall-Mounted Interface Module: TPS-4500IMW

Description

Functional Description

The TPS-4500IMW is designed specifically to serve as an optional interface module for the Crestron TPS-4500 tilt touchpanels. The module provides a clean, 1-gang mountable interface for direct connection to the touchpanel. The TPS-4500IMW creatively hides most of the connections behind the wall. A visible RJ45 connector can be camouflaged with a decora wallplate (not supplied) so that the unit blends into any setting.

Physical Description

The TPS-4500IMW, shown on the next page, is an option (can be purchased separately). The unit mounts into a 1-gang electrical box (recommended 2.5" depth). The back of the unit is silk-screened and provides a network and video input connectors. Once installed, there is only one RJ45 connector visible, which provides connection to the touchpanel (cable, CA15859, supplied with touchpanel).

I/O Ports

There are four I/O ports available on the TPS-4500IMW. Details of each are provided as bulleted items on page 3.

*Physical Views of the TPS-4500IMW
(Front with Insert Plate, Side, and Back)*

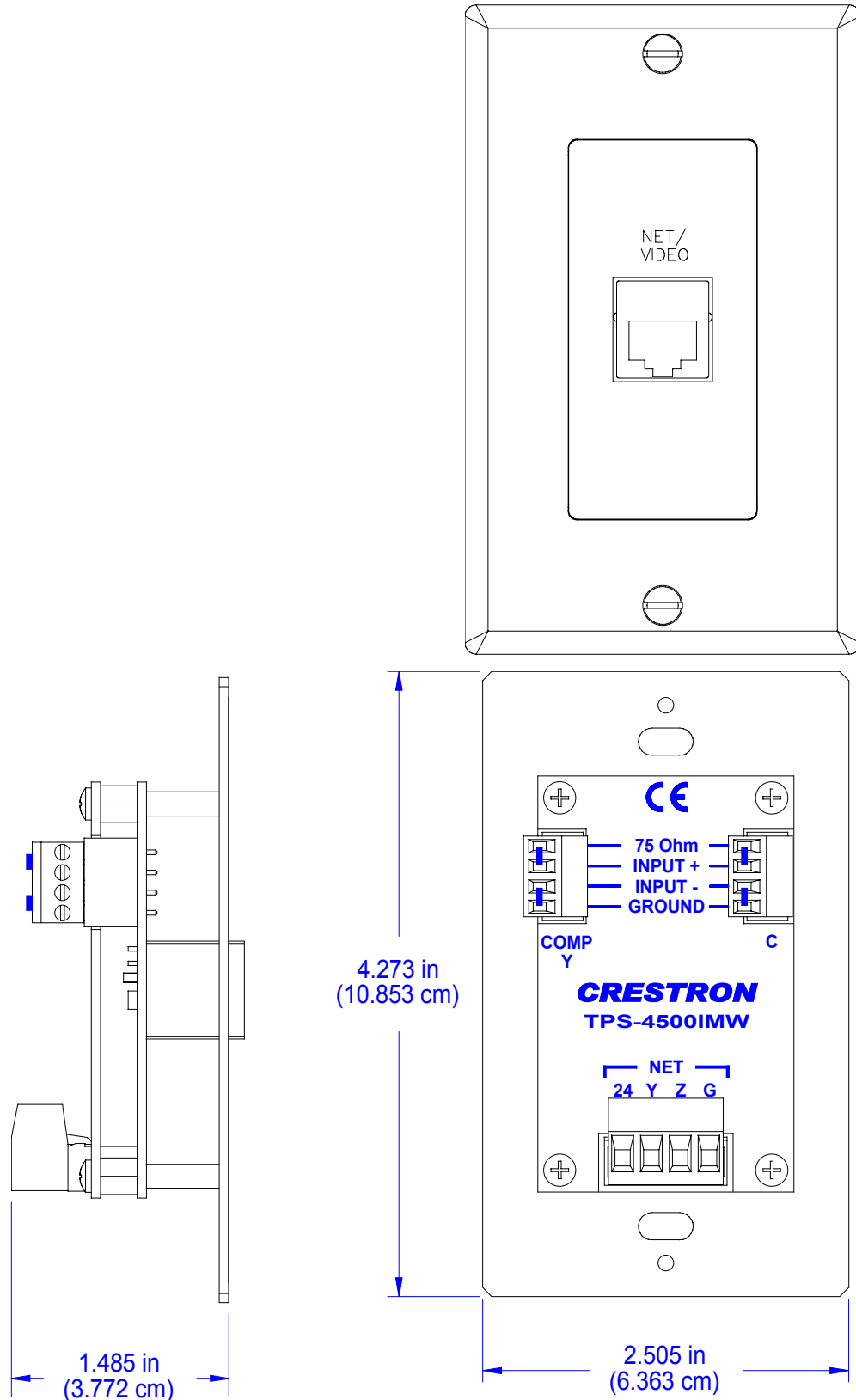

- **COMP Y and C** – These two (four-pin) ports on the back of the unit provide connection for a video source. The unit can accept either a single signal over one wire (composite video or **COMP**) or two separate signals: one for brightness (luminance or **Y**), and the other for color (chrominance or **C**). The port is made active with the purchase and installation of the TPS-VID, composite and S-video input TV video card, into the touchpanel. Consult the latest revision of the TPS-VID Operations & Installation Guide (Doc. 5869) for details.

NOTE: Except for differential input (balanced) video signal, the two (four-pin) video connectors with jumpers should be installed at all times. Refer to "Hardware Hookup" on page 5 for jumper details.

- **NET** – This four-pin connector is used to connect to other four-wire devices in the Cresnet system. If making network connections to Cresnet peripherals, refer to "Network Wiring" on page 4 for details.
- **NET/VIDEO** – This 10-position RJ45 mates with the TPS-4500 touchpanel and has a dual purpose. Refer to the descriptions and pinout table that follow this paragraph.
 1. This port provides network and power connection to the touchpanel.
 2. This port also makes available composite or S-video input for TV video card (with the purchase and installation of the TPS-VID). Consult the latest revision of the TPS-VID Operations & Installation Guide (Doc. 5869) for details.

NET/VIDEO Pinouts

PIN #	DESIGNATION	DESCRIPTION
1	+24V	Power (Network)
2	GND	Ground (Network)
3	C+	Chrominance (Positive)
4	C-	Chrominance (Negative)
5	Y	Data (Network)
6	Z	Data (Network)
7	Y+	Luminance (Positive)/Composite
8	Y-	Luminance (Negative)/Composite
9	GND	Ground (Network)
10	+24V	Power (Network)

Leading Specifications

The table below provides a summary of leading specifications for the TPS-4500IMW. Dimensions and weight are rounded to the nearest hundredth unit.

Leading Specifications for the TPS-4500IMW

SPECIFICATION	DETAILS
Video Input Impedance	75 Ohms (with jumper) 100 Ohms (without jumper)
Dimensions	Height: 4.27 in (10.85 cm) Width: 2.51 in (6.36 cm) Depth: 1.49 in (3.77 cm)
Weight	0.32 lb (0.14 kg)

As of the date of manufacture, the TPS-4500IMW has been tested and found to comply with specifications for CE marking.



Setup

Network Wiring

NOTE: When making wire connections, refer to the latest revision of the Cresnet Network Interconnect Drawing (Doc. 5411). The document can be obtained from the Downloads page (CABLES and MANUAL Libraries) of the Crestron website (www.crestron.com). Search for the CRESNET.PDF files.

When calculating the wire gauge for a particular network run, the length of the run and the power factor of each network unit to be connected must be taken into consideration. If network units are to be daisy-chained on the run, the load factor of each network unit to be daisy-chained must be added together to determine the load factor of the entire chain. The length of the run in feet and the load factor of the run should be used in the following resistance equation to calculate the value on the right side of the equation.

Resistance Equation

$$R < \frac{40,000}{L \times LF}$$

Where: R = Resistance (refer to following table). L = Length of run (or chain) in feet. LF = Load factor of entire run (or chain).
--

The required wire gauge should be chosen such that the resistance value is less than the value calculated in the resistance equation. Refer to the table after this paragraph.

Wire Gauge Values

RESISTANCE (R)	WIRE GAUGE
4	16
6	18
10	20
15	22
13	24 (Doubled-CAT 5)

NOTE: All network wiring must consist of two twisted-pairs. One twisted pair is the +24V conductor and the GND conductor and the other twisted pair is the Y conductor and the Z conductor.

NOTE: When daisy chaining network units, always twist the ends of the incoming wire and outgoing wire which share a pin on the network connector. After twisting the ends, tin the twisted connection with solder. Apply solder only to the ends of the twisted wires. Avoid tinning too far up or the tinned end becomes brittle and breaks. After tinning the twisted ends, insert the tinned connection into the network connector and tighten the retaining screw. Repeat the procedure for the other three network conductors.

Hardware Hookup**Connections to the Back of the TPS-4500IMW**

The TPS-4500IMW serves as an optional interface between the touchpanel and the Cresnet system. Refer to the illustration after this paragraph for proper connections; apply power last. When making network connections to the CNX Generation control system or Cresnet peripherals, refer to "Network Wiring" on page 4 for details. It is not necessary to make connections to a video source unless the TPS-VID has

been installed into the touchpanel and a video window object resides on a page within the uploaded VisionTools™ Pro-e project.

Hardware Hookup Connections to the Back of the TPS-4500IMW

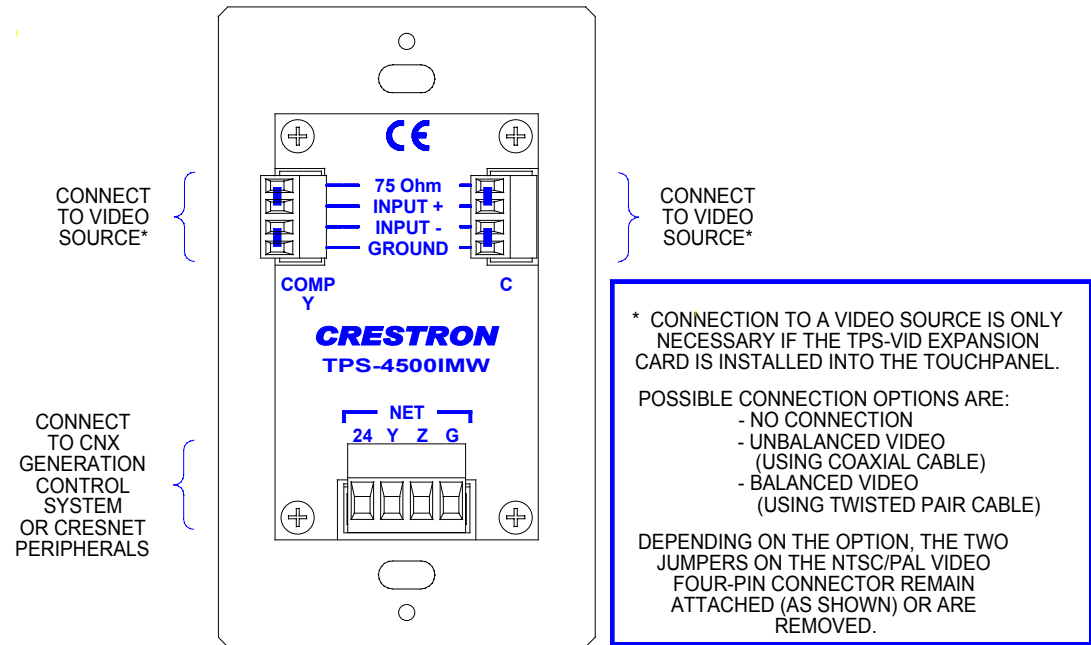

NOTE: If there is no video source, do not make connections to either NTSC/PAL video connector. However, leave connector and jumpers attached to the NTSC/PAL video four-pin connector on the TPS-4500IMW.

NOTE: Video balance is determined by external connections. Refer to the two diagrams that follow this note.

Unbalanced Using Coaxial Cable

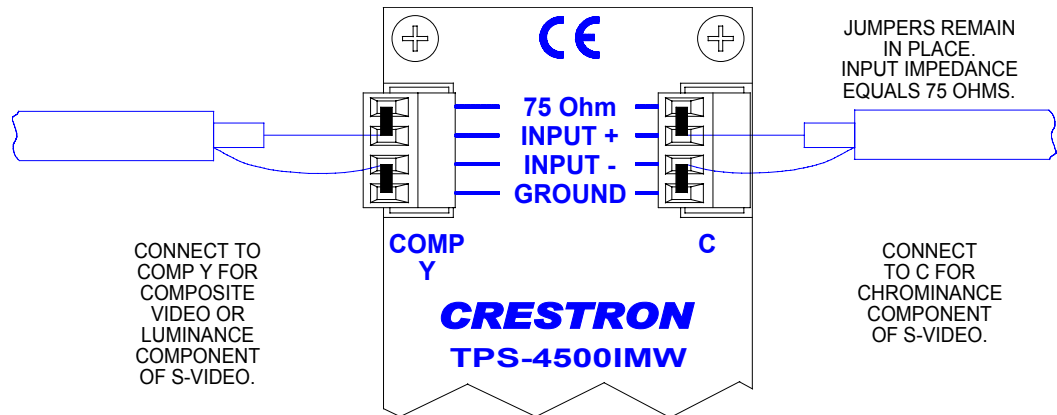

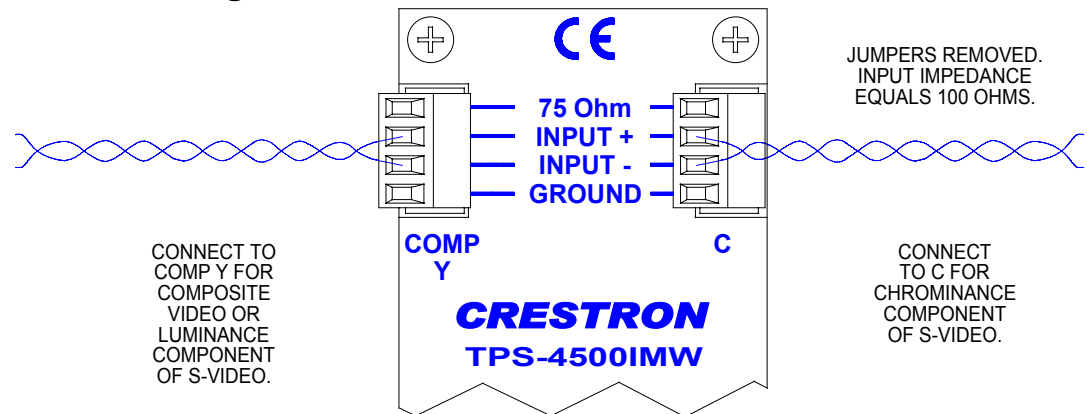
Balanced Using Twisted Pair Cable**Installation into the Electrical Box**

The TPS-4500IMW mounts into a 1-gang electrical box (recommended 2.5" depth). Verify that the unit is installed into the electrical box as shown after this paragraph. Use the orientation of the RJ45 connector as a guide. Secure the TPS-4500IMW to the electrical box with the two #6-32 flat head slotted screws (1-inch length), supplied.

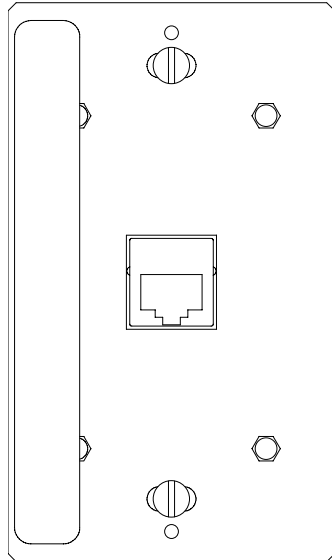
Installation of the TPS-4500IMW

Once the TPS-4500IMW is installed into a 1-gang electrical box, it can be covered with a decora wallplate, purchased separately. Crestron recommends Leviton, part number 80401-* (where * denotes an abbreviation that represents color). Refer to the list after this paragraph for available colors at the time of this printing.

Available Decora Wallplate Colors by Leviton

*	COLOR
NE	Black
NW	White
NA	Almond
NI	Ivory
NGY	Gray
NR	Red
N	Brown
NB	Blue

Remove the backing from the tape on the back of the silk-screened insert plate, supplied. Affix the insert plate into the opening in the decora wallplate. Refer to the diagram after this paragraph, for the proper orientation of the insert plate with respect to the installed TPS-4500IMW.

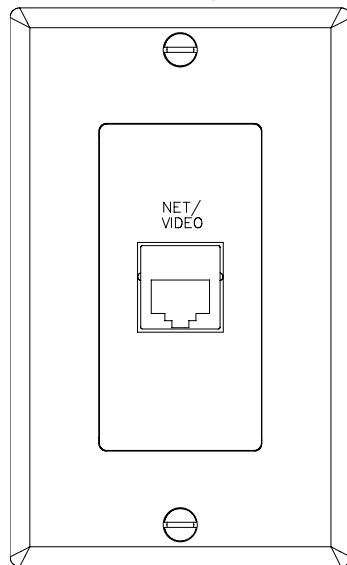
Orientation of the Insert Plate

Connect the TPS-4500IMW to the touchpanel using the network/video (10-pin) cable, supplied with touchpanel.

Problem Solving

Troubleshooting

The table below provides corrective action for possible trouble situations. If further assistance is required, please contact a Crestron customer service representative.

TPS-4500IMW Troubleshooting

TROUBLE	POSSIBLE CAUSE(S)	CORRECTIVE ACTION
Touchpanel does not function.	Touchpanel is not communicating to the network.	Use Performance Viewport (via SIMPL Windows or VT Pro-e) to poll the network. Verify network connection to the touchpanel.
	Touchpanel is not receiving network power.	Confirm that power is supplied to the network.
Touchpanel is not responding.	Incorrect network wiring.	Touch screen to remove message and verify correct wiring to all connectors.

Further Inquiries

If after reviewing this Operations Guide for the TPS-4500IMW, you cannot locate specific information or have questions, please take advantage of Crestron's award winning customer service team by calling:

- In the US and Canada, call Crestron's corporate headquarters at 1-888-CRESTRON [1-888-273-7876] or 1-201-767-3400.
- In Europe, call Crestron International at +32-15-50-99-50.
- In Asia, call Crestron Asia at +852-2341-2016.
- In Latin America, call Crestron Latin America at +5255-5093-2160.
- In Australia and New Zealand, call Crestron Pacific at +613-9480-2999.

Future Updates

As Crestron improves functions, adds new features, and extends the capabilities of the TPS-4500IMW, additional information may be made available as manual updates. These updates are solely electronic and serve as intermediary supplements prior to the release of a complete technical documentation revision.

Check the Crestron website (www.crestron.com) periodically for manual update availability and its subjective value. Updates are available from the Downloads | Product Manuals section and are identified as an “Addendum” in the Download column.

Return and Warranty Policies

Merchandise Returns / Repair Service

1. No merchandise may be returned for credit, exchange, or service without prior authorization from CRESTRON. To obtain warranty service for CRESTRON products, contact the factory and request an RMA (Return Merchandise Authorization) number. Enclose a note specifying the nature of the problem, name and phone number of contact person, RMA number, and return address.
2. Products may be returned for credit, exchange, or service with a CRESTRON Return Merchandise Authorization (RMA) number. Authorized returns must be shipped freight prepaid to CRESTRON, Cresskill, N.J., or its authorized subsidiaries, with RMA number clearly marked on the outside of all cartons. Shipments arriving freight collect or without an RMA number shall be subject to refusal. CRESTRON reserves the right in its sole and absolute discretion to charge a 15% restocking fee, plus shipping costs, on any products returned with an RMA.
3. Return freight charges following repair of items under warranty shall be paid by CRESTRON, shipping by standard ground carrier. In the event repairs are found to be non-warranty, return freight costs shall be paid by the purchaser.

CRESTRON Limited Warranty

CRESTRON ELECTRONICS, Inc. warrants its products to be free from manufacturing defects in materials and workmanship under normal use for a period of three (3) years from the date of purchase from CRESTRON, with the following exceptions: disk drives and any other moving or rotating mechanical parts, pan/tilt heads and power supplies are covered for a period of one (1) year; touchscreen display and overlay components are covered for 90 days; batteries and incandescent lamps are not covered.

This warranty extends to products purchased directly from CRESTRON or an authorized CRESTRON dealer. Purchasers should inquire of the dealer regarding the nature and extent of the dealer's warranty, if any.

CRESTRON shall not be liable to honor the terms of this warranty if the product has been used in any application other than that for which it was intended, or if it has been subjected to misuse, accidental damage, modification, or improper installation procedures. Furthermore, this warranty does not cover any product that has had the serial number altered, defaced, or removed.

This warranty shall be the sole and exclusive remedy to the original purchaser. In no event shall CRESTRON be liable for incidental or consequential damages of any kind (property or economic damages inclusive) arising from the sale or use of this equipment. CRESTRON is not liable for any claim made by a third party or made by the purchaser for a third party.

CRESTRON shall, at its option, repair or replace any product found defective, without charge for parts or labor. Repaired or replaced equipment and parts supplied under this warranty shall be covered only by the unexpired portion of the warranty.

Except as expressly set forth in this warranty, CRESTRON makes no other warranties, expressed or implied, nor authorizes any other party to offer any other party to offer any warranty, including any implied warranties of merchantability or fitness for a particular purpose. Any implied warranties that may be imposed by law are limited to the terms of this limited warranty. This warranty statement supercedes all previous warranties.

Trademark Information

All brand names, product names, and trademarks are the sole property of their respective owners. Windows is a registered trademark of Microsoft Corporation. Windows95/98/Me/XP and WindowsNT/2000 are trademarks of Microsoft Corporation.



Crestron Electronics, Inc.
15 Volvo Drive Rockleigh, NJ 07647
Tel: 888.CRESTRON
Fax: 201.767.7576
www.crestron.com

Operations Guide – DOC. 5913
02.01

Specifications subject to
change without notice.