

TPS – 6000, 5000 & 4500 INSTALLATION GUIDE



INDEX:

- A) [CONNECTING THE TPS PANEL USING THE TPS-IMC](#)
 - 1) [CONNECTING THE TPS PANEL TO THE TPS-IMC](#)
 - 2) [CONNECTING THE AUDIO TO THE TPS-IMC](#)
 - 3) [CONNECTING THE VIDEO TO THE TPS-IMC](#)
 - 4) [CONNECTING THE RGB TO THE TPS-IMC](#)

- B) [CONNECTING THE TPS PANEL USING THE TPS-IMC-BV](#)
 - 1) [CONNECTING THE TPS PANEL TO THE TPS-IMC-BV](#)
 - 2) [CONNECTING THE AUDIO TO THE TPS-IMC-BV](#)
 - 3) [CONNECTING THE VIDEO TO THE TPS-IMC-BV](#)
 - 4) [CONNECTING THE RGB TO THE TPS-IMC-BV](#)

- C) [CONNECTING THE TPS PANEL USING THE TPS-IMW](#)
 - 1) [CONNECTING THE TPS PANEL TO THE TPS-IMW](#)
 - 2) [CONNECTING THE AUDIO TO THE TPS-IMW](#)
 - 3) [CONNECTING THE VIDEO TO THE TPS-IMW](#)
 - 4) [CONNECTING THE RGB TO THE TPS-IMW](#)

- D) [CONNECTING ETHERNET TO THE TPS PANEL](#)

- E) [CUSTOM INSTALLATION & CABLES](#)
 - 1) [TPS-BLOCK10](#)
 - 2) [TPS CABLES](#)

CONNECTING THE TPS PANEL USING THE TPS-IMC

Panel Connection for 6000, 5000 and 4500.

- One supplied with each TPS-5000 and TPS-6000; add additional units to provide connectivity at multiple locations.
- Provides breakout from the 10-pin Net/Video cable and 9-pin audio cable (15' included with touchpanel; other lengths available.)
- For Cresnet only, TPS-IMC is not mandatory if audio and video are not being used, although a custom 10-pin cable solution would be required (see TPS-Block10 below.)

1) CONNECTING THE TPS PANEL TO THE TPS-IMC

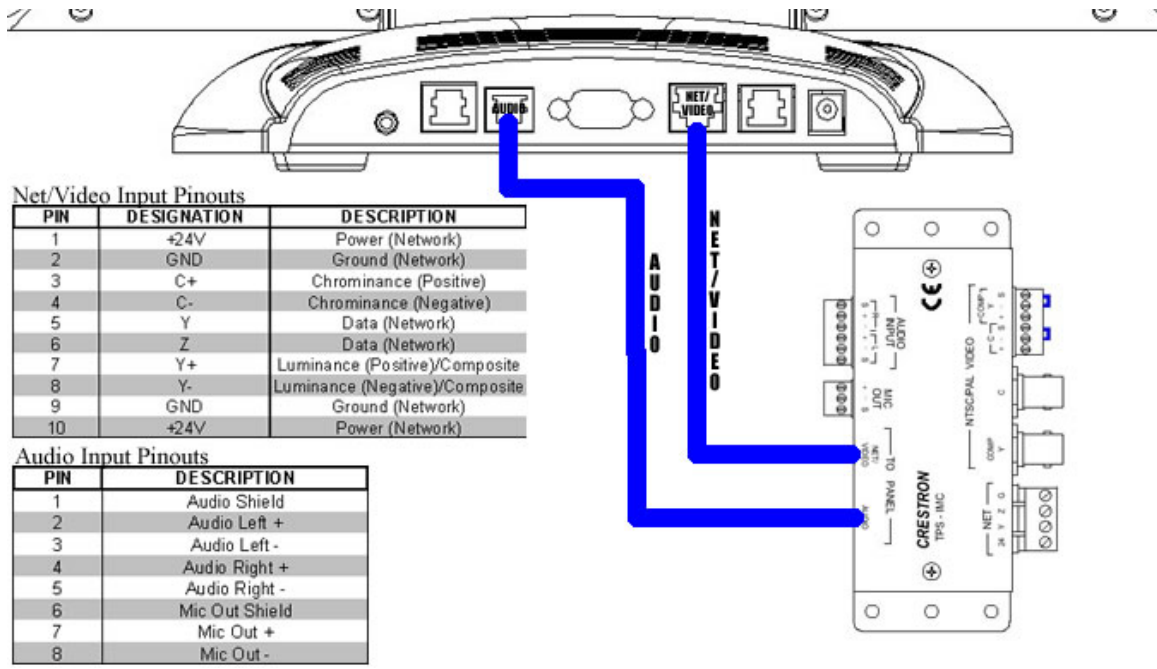

2) CONNECTING THE AUDIO TO THE TPS-IMC

Audio is available for the TPS-6000 and 5000.

- TPS-IMC supports balanced and unbalanced signals.

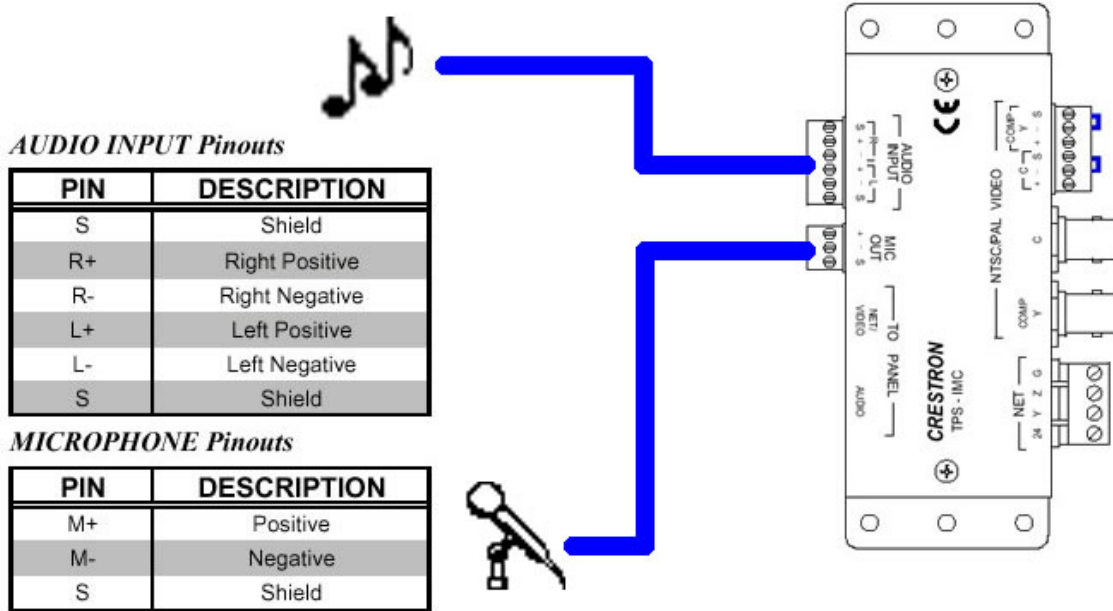

3) CONNECTING THE VIDEO TO THE TPS-IMC

Video is available for the TPS-6000, 5000 and 4500.

- TPS-IMC supports balanced and unbalanced video.

Before video can be enabled the TPS-VID card must be installed.

(For further information on installation please reference the TPS-VID manual)

Install TPS-VID

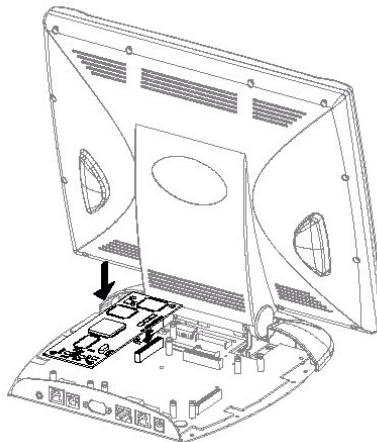

Connect to a video source only if the TPS-VID expansion card is installed in the touchpanel. The BNC connector and screw terminal mini Phoenix connector is connected in parallel. Possible options are no connection, balance video using twisted pair cable, unbalance video using twisted pair cable, or unbalanced video using coax cable. Depending on the option, the two jumpers on the NTSC/PAL VIDEO six-pin connector remain attached or are removed.

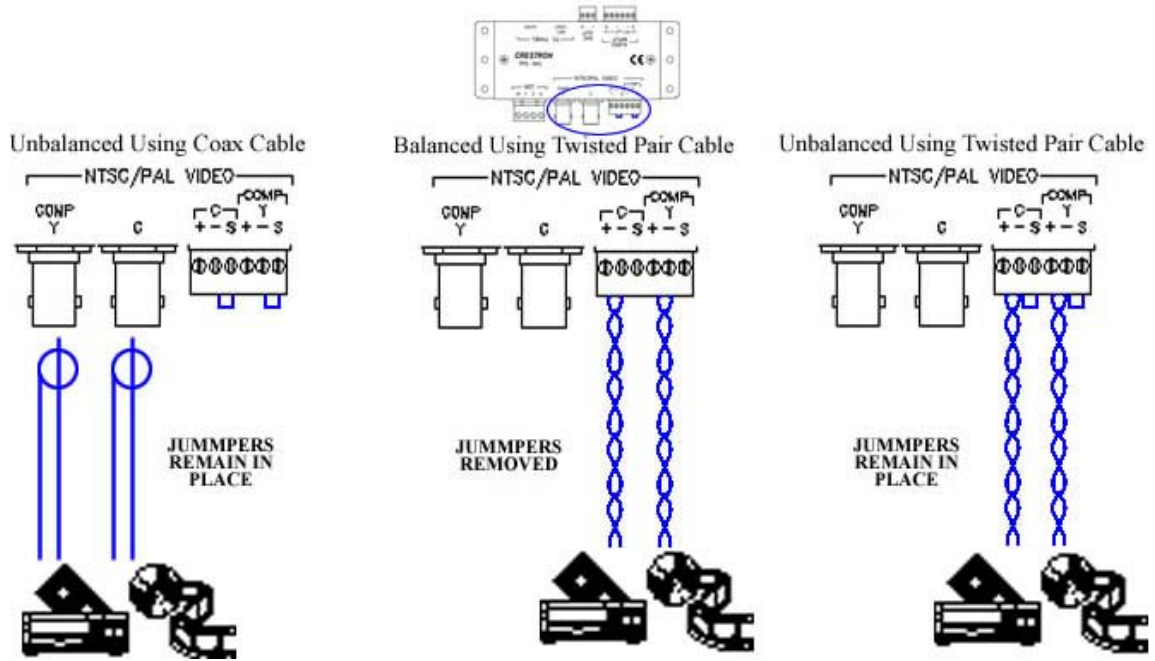

4) CONNECTING THE RGB TO THE TPS-IMC

RGB is only available for the TPS-6000 and 5000.

Note: RGB video does not pass through the TPS-IMC. (see below)

Before RGB video can be enabled the TPS-XVGA must be installed.

(For further information on installation please reference the TPS-XVGA manual)

Install TPS-XVGA

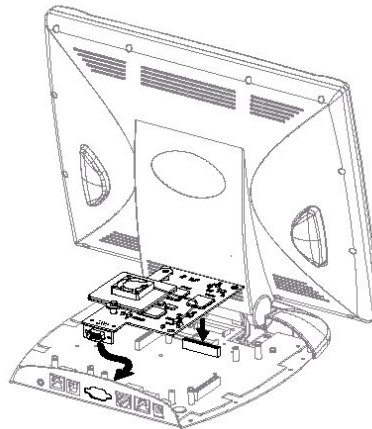

RGB(15PIN DB CONNECTION

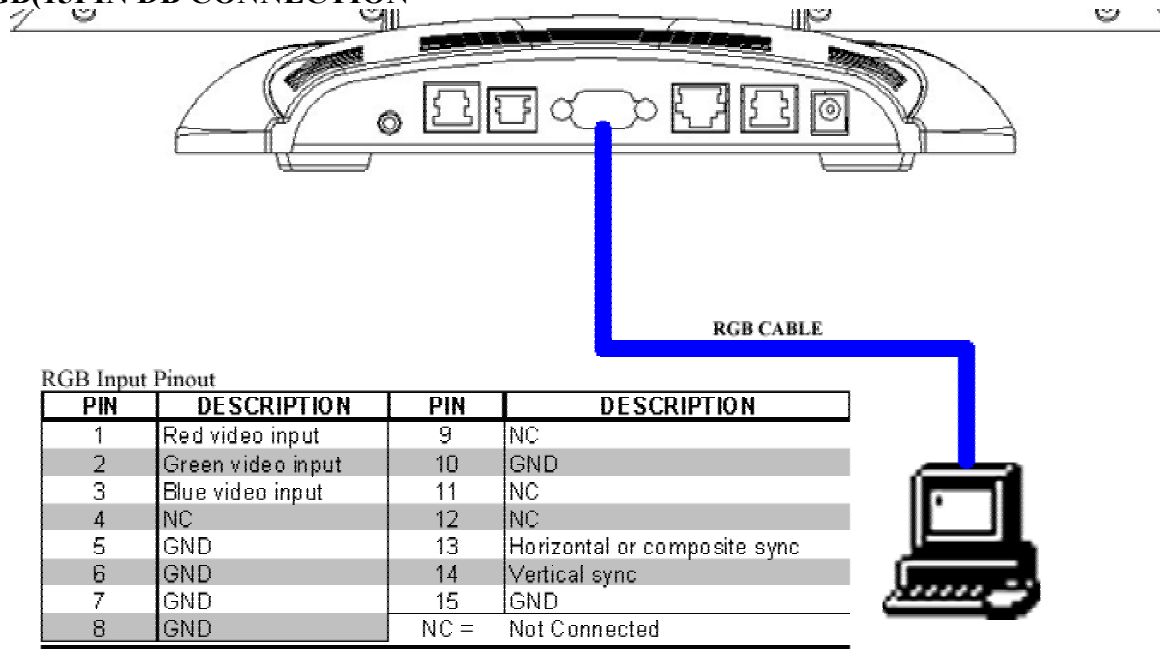

CONNECTING THE TPS PANEL USING THE TPS-IMC-BV

Panel Connection for 6000 and 5000.

Provides all of the functionality of a regular TPS-IMC and adds buffering and breakout for the 10-pin balanced XVGA cable, and a 8-pin audio cable.
Add additional units to provide connectivity at multiple locations.

1) CONNECTING THE TPS PANEL TO THE TPS-IMC-BV

NET/VIDEO(10PIN/RJ45)

RGB(10PIN/RJ45)

AUDIO(8PIN/RJ45)

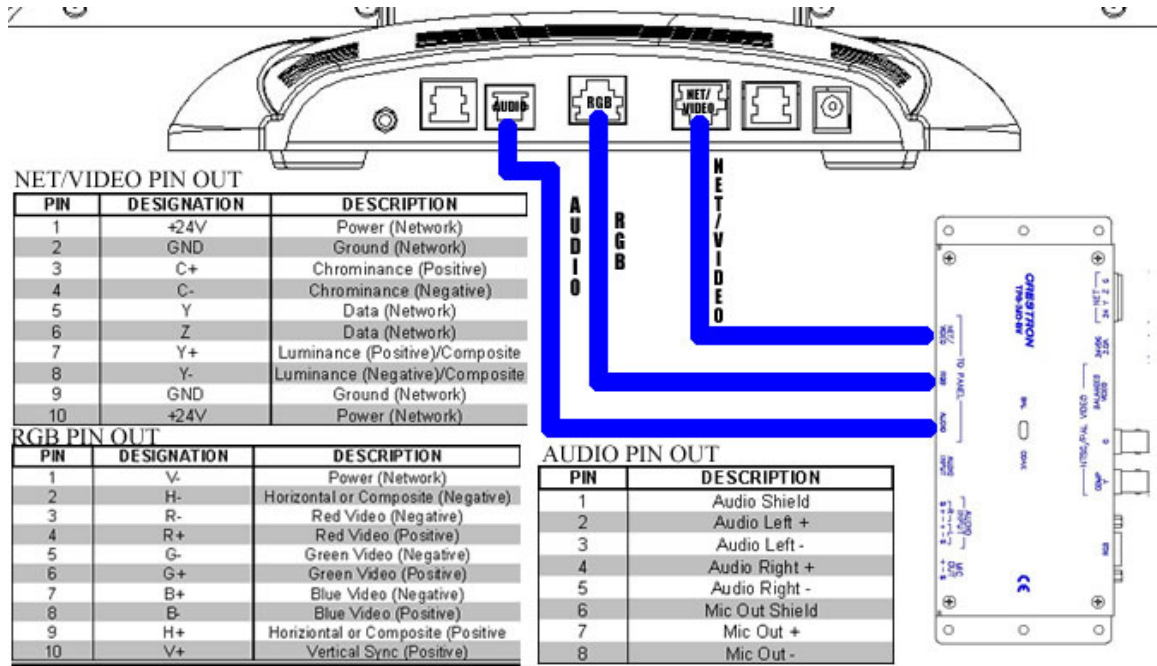

2) CONNECTING THE AUDIO TO THE TPS-IMC-BV

Audio is available for the TPS-6000 and 5000.

The TPS-IMC-BV supports Balanced and Unbalanced inputs.

AUDIO INPUT (RJ45) Pinouts

PIN	DESCRIPTION
1	Mic +
2	Mic -
3	Mic +
4	Audio Left +
5	Audio Left -
6	Mic -
7	Audio Right +
8	Audio Right -

AUDIO INPUT Pinouts

PIN	DESCRIPTION
S	Shield
R+	Right Positive
R-	Right Negative
L+	Left Positive
L-	Left Negative
S	Shield

MICROPHONE Pinouts

PIN	DESCRIPTION
M+	Positive
M-	Negative
S	Shield

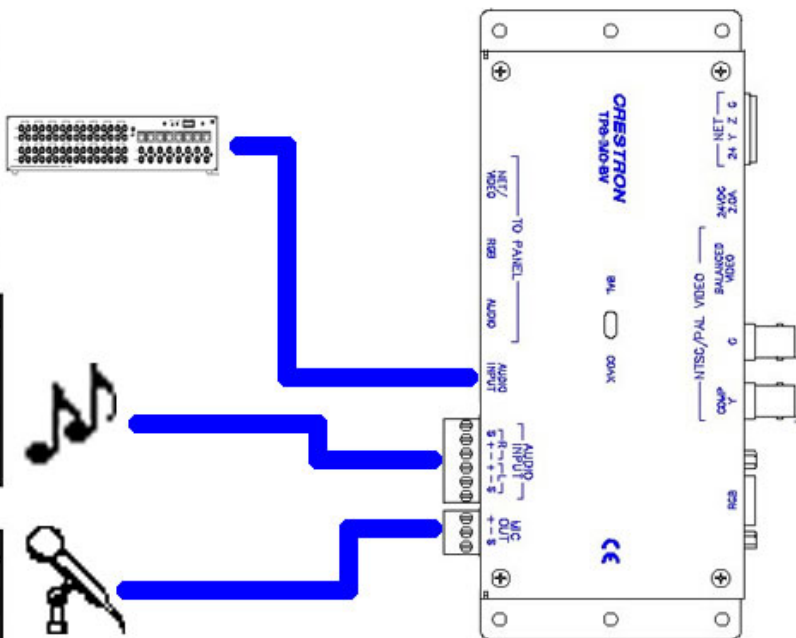

3) CONNECTING THE VIDEO TO THE TPS-IMC-BV

Video is available for the TPS-6000, 5000 and 4500.

Before video can be enabled the TPS-VID card must be installed.

(For further information on installation please reference the TPS-VID manual)

Install TPS-VID

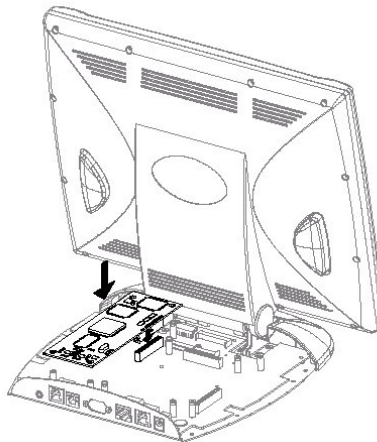

Connect to a video source only if the TPS-VID expansion card is installed in the touchpanel. The BNC connectors and RJ45 connector are connected in parallel. Use one or the other. For balanced video, use the RJ45.

Unbalanced Using Coax Cable

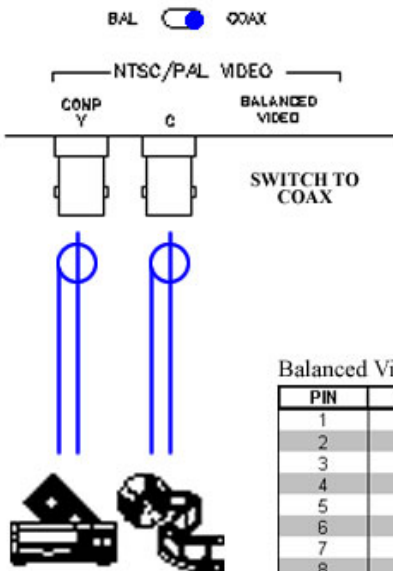

Balanced Using Cat 5

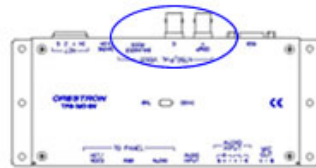
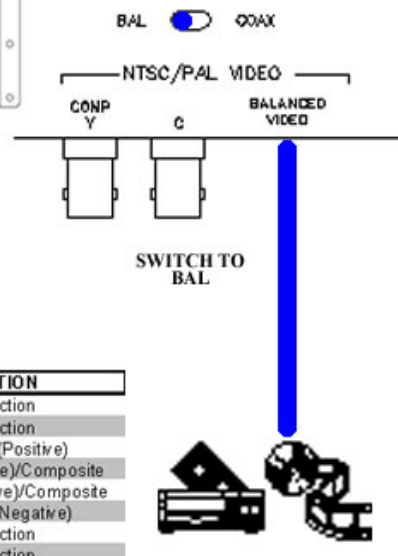

Balanced Video Input Pinouts

PIN	DESIGNATION	DESCRIPTION
1	N/C	No Connection
2	N/C	No Connection
3	C+	Chrominance (Positive)
4	Y+	Luminance (Positive)/Composite
5	Y-	Luminance (Negative)/Composite
6	C-	Chrominance (Negative)
7	N/C	No Connection
8	N/C	No Connection

4) CONNECTING THE RGB TO THE TPS-IMC-BV

RGB is only available for the TPS-6000 and 5000.

- Alternate XVGA card for TPS-6000 and 5000.
- Provides a 10-pin connector directly on the back of the touchpanel base.
- TPS-IMC-BV ships with 15' triamese cable consisting of a 10-pin net/video cable, a 10-pin balanced XVGA cable, and an 8-pin audio cable.
- Also included is the TPS-IMC-BV.

Before RGB video can be enabled the TPS-XVGA-BV must be installed.

(For further information on installation please reference the TPS-XVGA-BV manual)

Install TPS-XVGA-BV

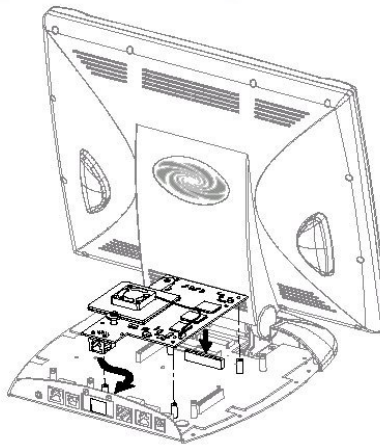

15 PIN DB CONNECTION

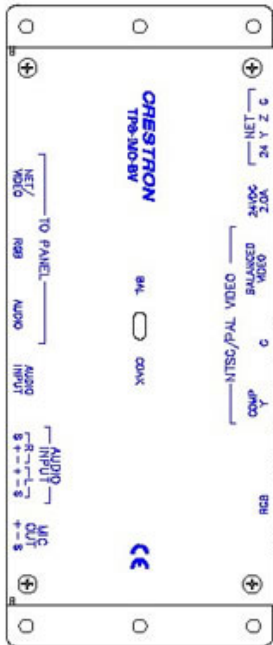

PIN	DESCRIPTION	PIN	DESCRIPTION
1	Red video input	9	NC
2	Green video input	10	GND
3	Blue video input	11	NC
4	NC	12	NC
5	GND	13	Horizontal or composite sync
6	GND	14	Vertical sync
7	GND	15	GND
8	GND	NC =	Not Connected

CONNECTING THE TPS PANEL USING THE TPS-IMW

Panel Connection for 6000, 5000 & 4500

2-Gang wall-mount version of TPS-IMC.

If audio is not required, substitute TPS-4500IMW.

1) CONNECTING THE TPS PANEL TO THE TPS-IMW

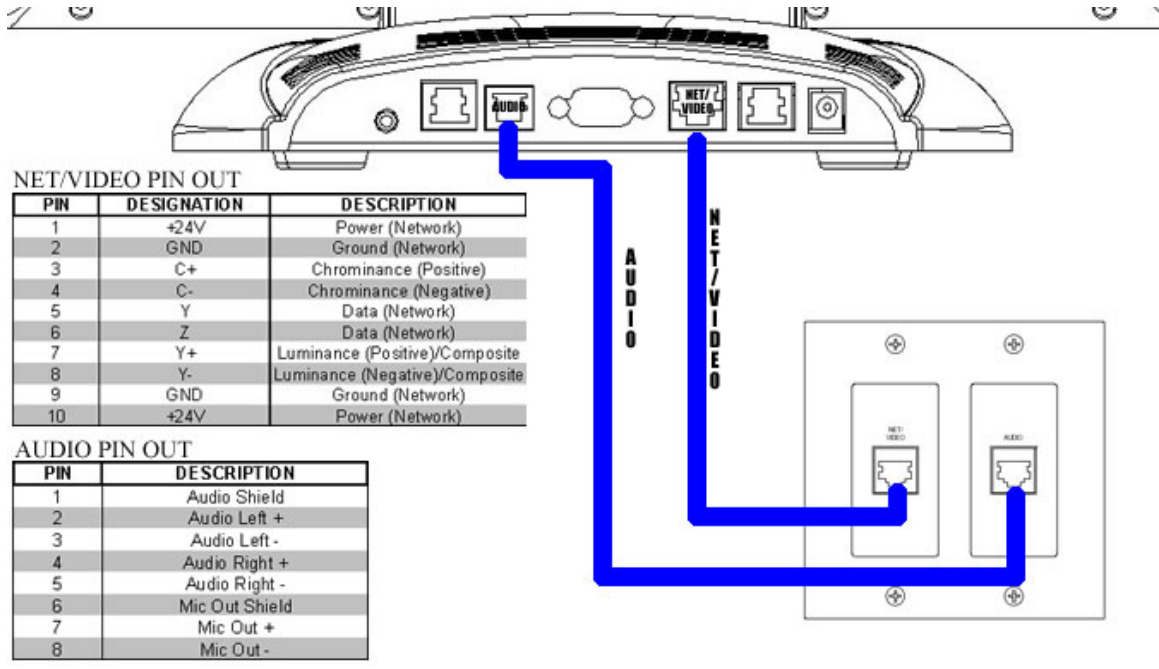

2) CONNECTING THE AUDIO TO THE TPS-IMW

Audio is available for the TPS-6000 and 5000.

TPS-IMW supports balanced and unbalanced audio.

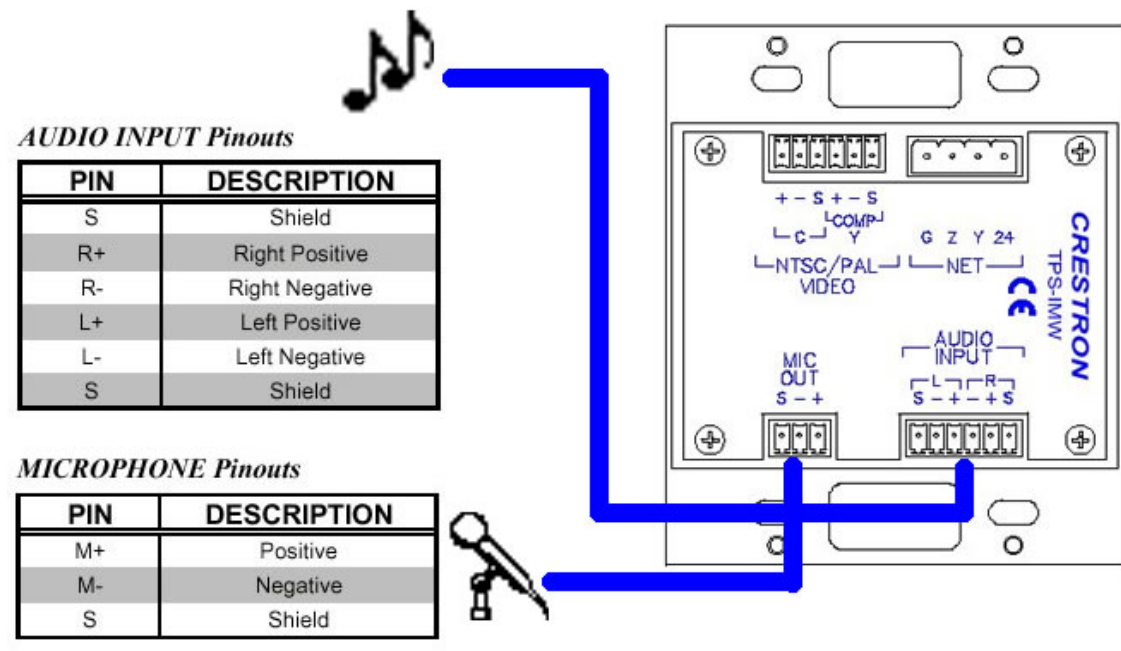

3) CONNECTING THE VIDEO TO THE TPS-IMW

Video is available for the TPS-6000, 5000 and 4500.

TPS-IMW supports balanced and unbalanced video

Before video can be enabled the TPS-VID card must be installed.

(For further information on installation please reference the TPS-VID manual)

Install TPS-VID

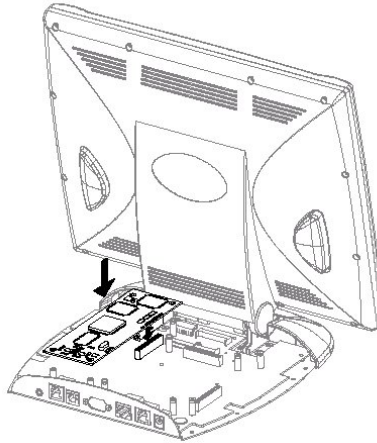

Connect to a video source only if the TPS-VID expansion card is installed in the touchpanel. Possible options are no connection, balance video using twisted pair cable, or unbalance video using twisted pair cable. Depending on the option, the two jumpers on the NTSC/PAL VIDEO six-pin connector remain attached or are removed.

Balanced Using Twisted Pair Cable

Unbalanced Using Twisted Pair Cable

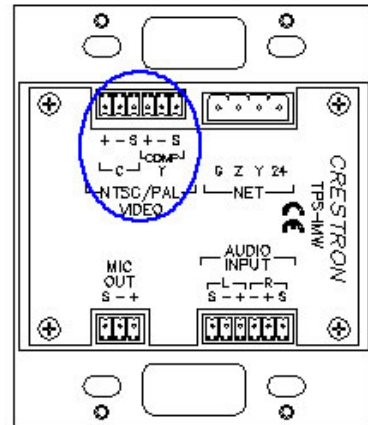
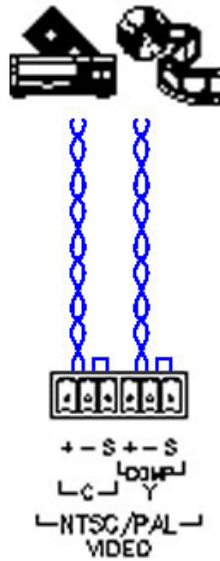
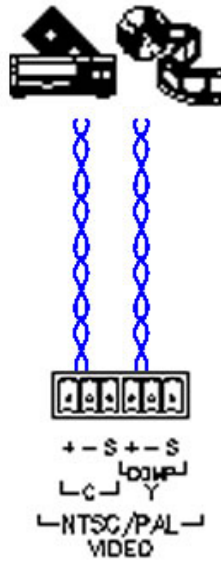

4) CONNECTING THE RGB TO THE TPS-IMW

RGB is only available for the TPS-6000 and 5000.

Note: RGB video does not pass through the TPS-IMW.(see below)

Before RGB video can be enabled the TPS-XVGA must be installed.

(For further information on installation please reference the TPS-XVGA manual)

Install TPS-XVGA

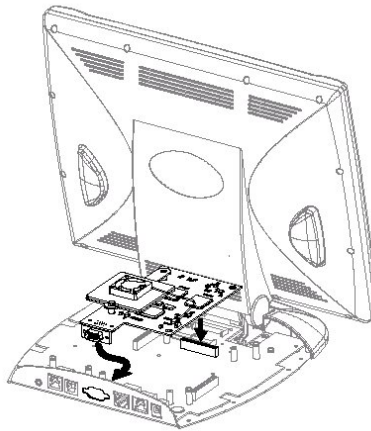

RGB 15-PIN DB CONNECTION

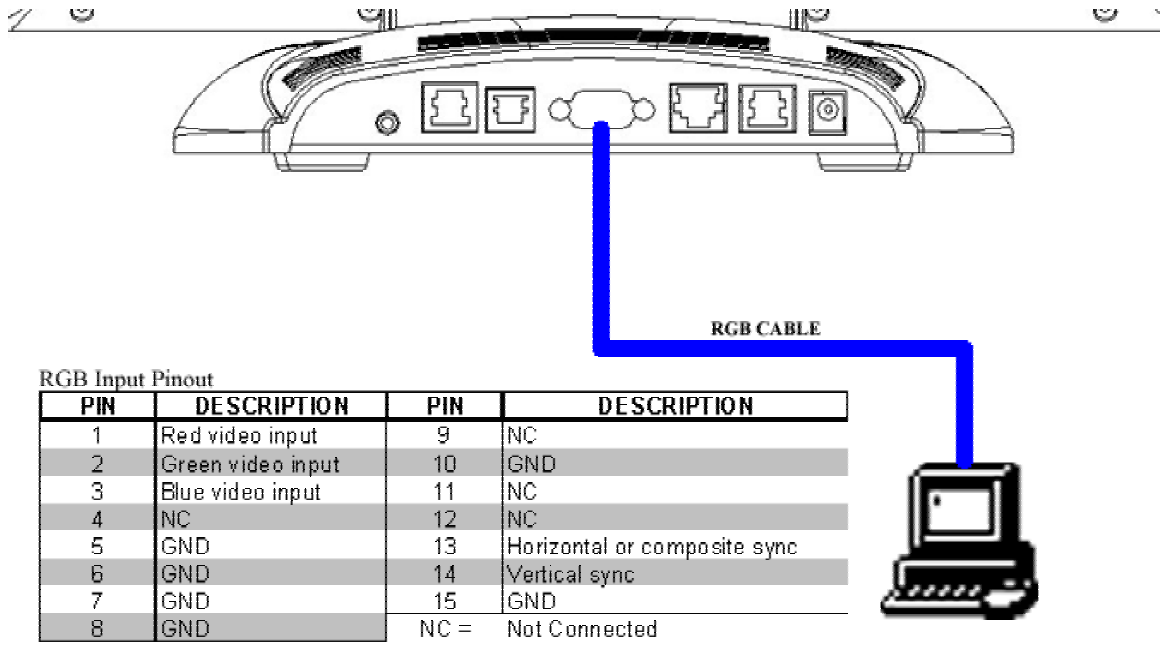

CONNECTING ETHERNET TO THE TPS PANEL

Ethernet interface card for TPS-6000 and TPS-5000.

Does not connect to IMC or IMW.

Requires 3rd-party CAT5 cable connected directly to any LAN port.

Before Ethernet can be enabled the TPS-ENET card must be installed.

(For further information on installation please reference the TPS-ENET manual)

Install TPS-ENET

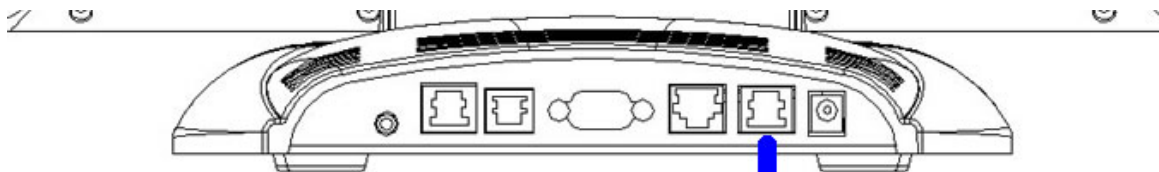
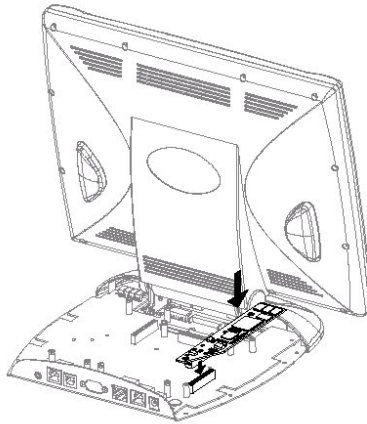

LAN Port Specifications for RJ45 port

PIN	DESCRIPTION
1	TD+
2	TD-
3	RD+
4	Connected to pin 5
5	Connected to pin 4
6	RD-
7	Connected to pin 8
8	Connected to pin 7

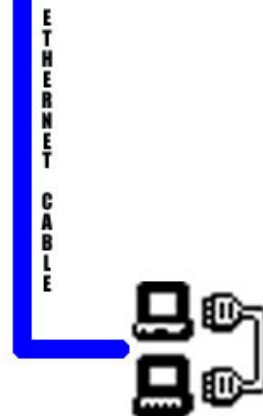

CUSTOM INSTALLATION & CABLES

1) TPS-BLOCK10

Provides a panel-mount connection for one 10-pin net/video or one 10-pin X VGA cable.

Use a 3rd TPS-BLOCK10 or any standard panel-mount 8-pin RJ-45 jack for the audio.

The TPS-BLOCK10 falls in line between the touchpanel and the IMC or IMC-BV breakout

The total cable length between the touchpanel and the IMC or IMC-BV should be kept as short as possible, never to exceed 50'.

Several manufacturers are providing solutions to allow mounting of one or more TPS-BLOCK10's into their interface panels and pop-ups.

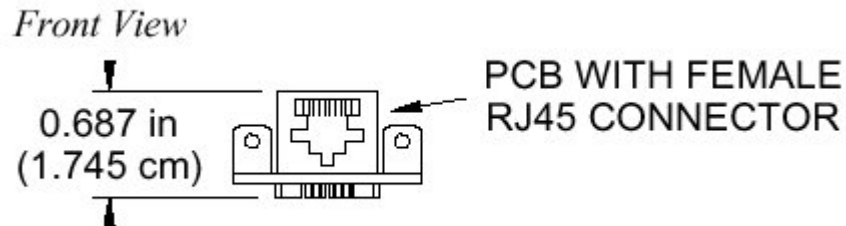

TPS-BLOCK10 EXTRON AAP

Panels are 2-Space AAP's and allow the mounting of a Single TPSBLOCK-10 assembly or (2) TPS BLOCK-10 assemblies.

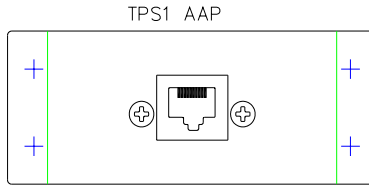

70-195-01,11,21,51
2 space AAP panel
Single connector

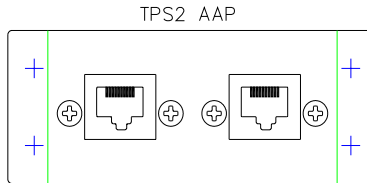

70-196-02,12,22,52
2 space AAP panel
Double connector

2) TPS CABLES

TPS-CBL-3/6/9

Maximum cable length is 30ft for the Net/Video cable.

Cable View

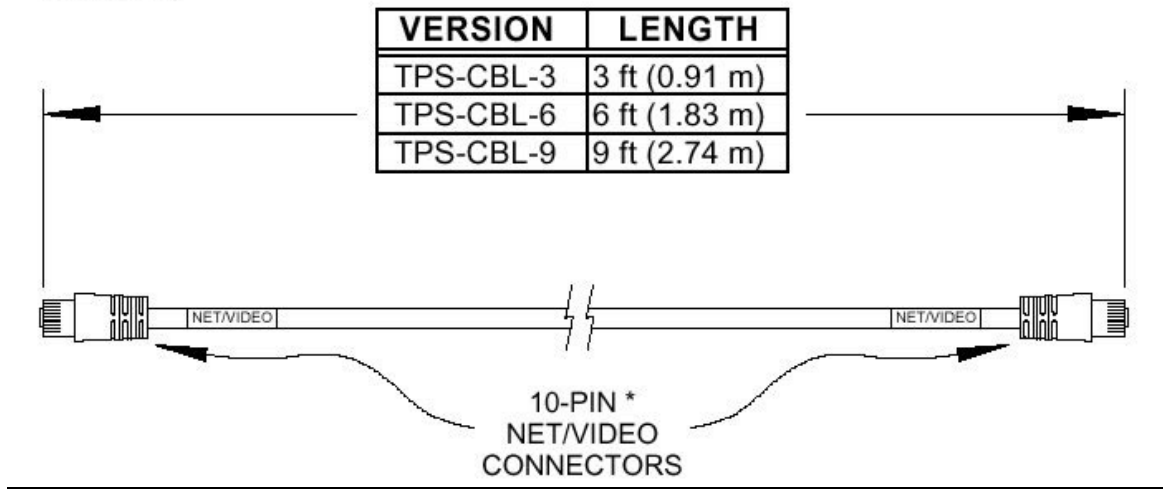

TPS-CBL-S3/6/9

Maximum cable length for the Net/Video and Audio cable is 30ft.

Siamese Cable View

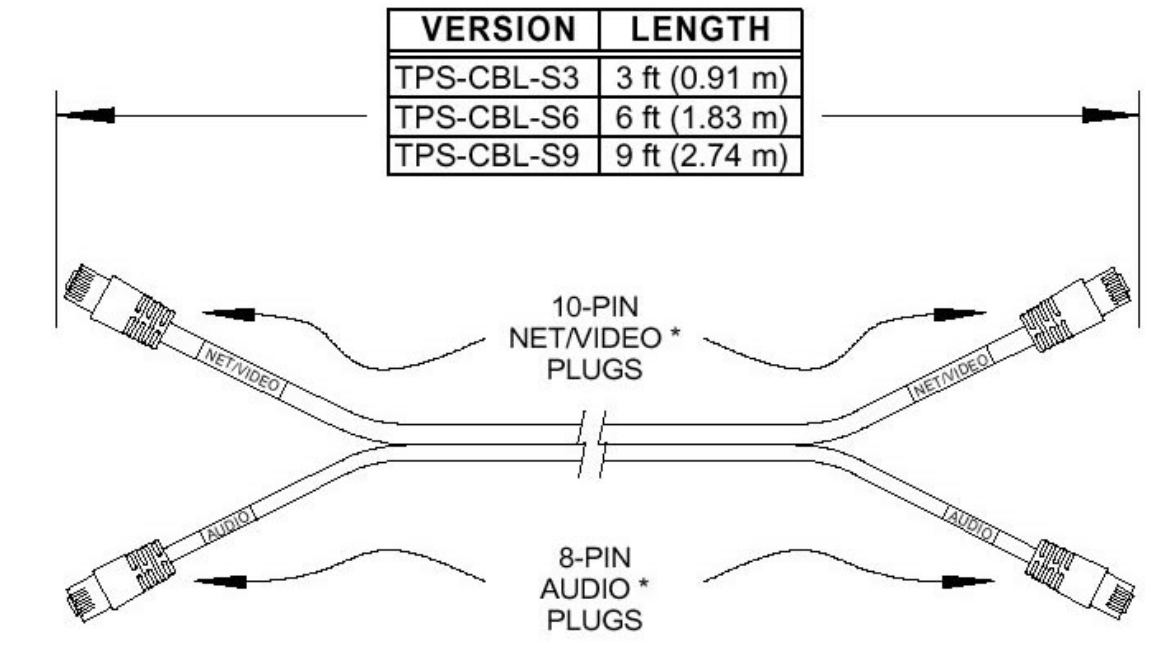

TPS-CBL-T3/6/9

Maximum cable length for the Net/Video, Audio and RGB cable is 30ft.

Triamese Cable View

VERSION	LENGTH
TPS-CBL-T3	3 ft (0.91 m)
TPS-CBL-T6	6 ft (1.83 m)
TPS-CBL-T9	9 ft (2.74 m)

