

# FT2A-UTK-SHELF

## Under-Table Utility Shelf for FT2 Series

Provides a convenient solution for holding a DigitalMedia™ transmitter or similar device beneath the table as part of a complete Crestron® FT2 series FlipTop™ installation. Measures 12.16 x 10.08 inches (309 x 256 mm) and supports a maximum weight of 5 pounds (2.3 kg). Includes raised edges to prevent items from sliding off. Attaches easily without tools to any side of the FlipTop chassis beneath the table.

A maximum of two shelves may be attached to a single FlipTop, with each shelf installed on opposing sides (either left and right, or front and rear). Shelves cannot be installed on the same side as a cable retractor or power supply (although power supplies may be placed on the shelf). When installed, the shelf surface sits 4.1 inches (104 mm) below the top surface of the table. Subtract the tabletop thickness to determine the vertical clearance available for devices placed on the shelf.

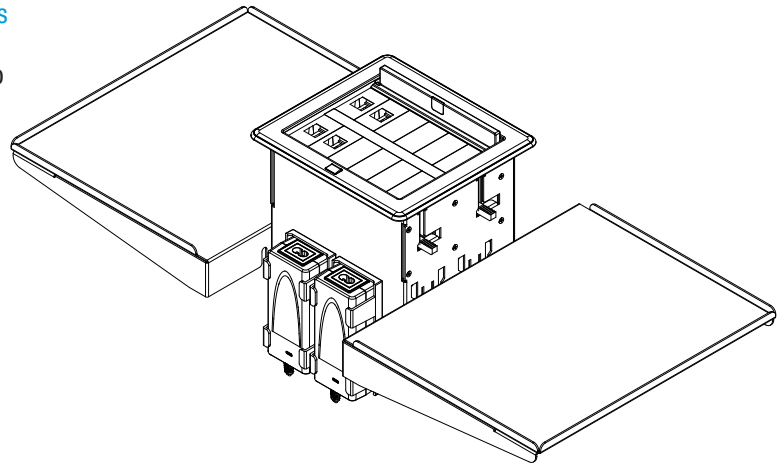

### Notes:

This product may be purchased from an authorized Crestron dealer. To find a dealer, please contact the Crestron sales representative for your area. A list of sales representatives is available online at <https://www.crestron.com/How-To-Buy/Find-a-Representative> or by calling 855-263-8754.

The specific patents that cover this and other Crestron products are listed online at <https://www.crestron.com/legal/patents>.

Certain Crestron products contain open source software. For specific information, please visit <https://www.crestron.com/opensource>.

Crestron, the Crestron logo, DigitalMedia, and FlipTop are either trademarks or registered trademarks of Crestron Electronics, Inc. in the United States and/or other countries. Other trademarks, registered trademarks, and trade names may be used in this document to refer to either the entities claiming the marks and names or their products. Crestron disclaims any proprietary interest in the marks and names of others. Crestron is not responsible for errors in typography or photography. Specifications are subject to change without notice. ©2018 Crestron Electronics, Inc.

