

Functional Summary

The CAEN-CK-7x1 & 7x2 CAEN Cover Extension Kits are designed to increase the overall depth of the CAEN-7x1 and CAEN-7x2 automation enclosures by 1.5 inches. Adding depth to these enclosures allows the enclosure to accommodate excess wiring and third-party devices that may not normally fit in the standard enclosure.

CAEN-CK Overall Dimensions (Front and Side Views)

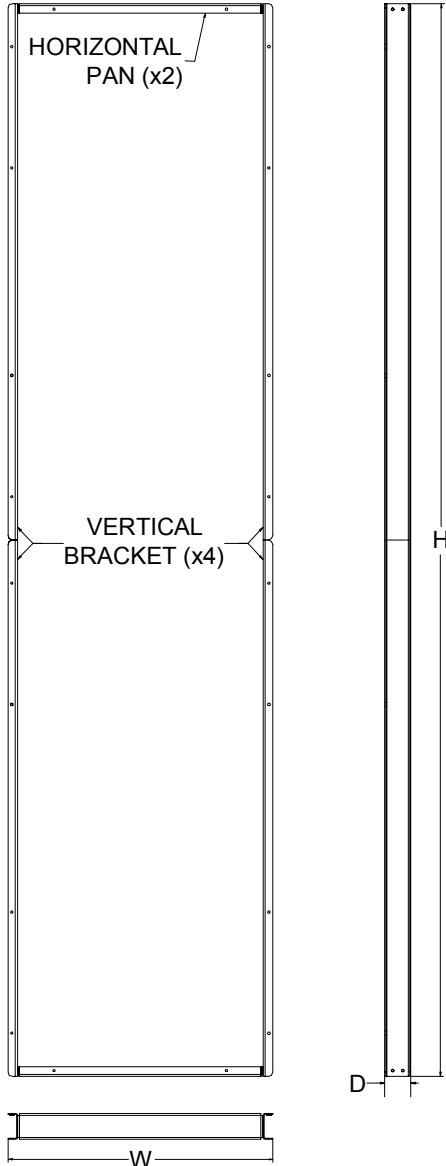

The following table lists the dimensions for the CAEN-CK-7x1 and CAEN-CK-7x2.

Dimensions of Enclosure Cover Kits

DIMENSION	CAEN-CK-7x1	CAEN-CK-7x2
H	62.00 in	62.00 in
D	1.50 in	1.50 in
W	15.35 in	26.50 in

Installation

The cover extension kit should be attached to a Crestron® Automation Enclosure in accordance with all national and local electrical codes. The enclosure cover and screws must be removed prior to installation. Both must be retained and used with the supplied screws to complete the following procedure.

Refer to the following procedure shown in the installation diagram when installing the CAEN Cover Extension Kit.

Installation Diagram

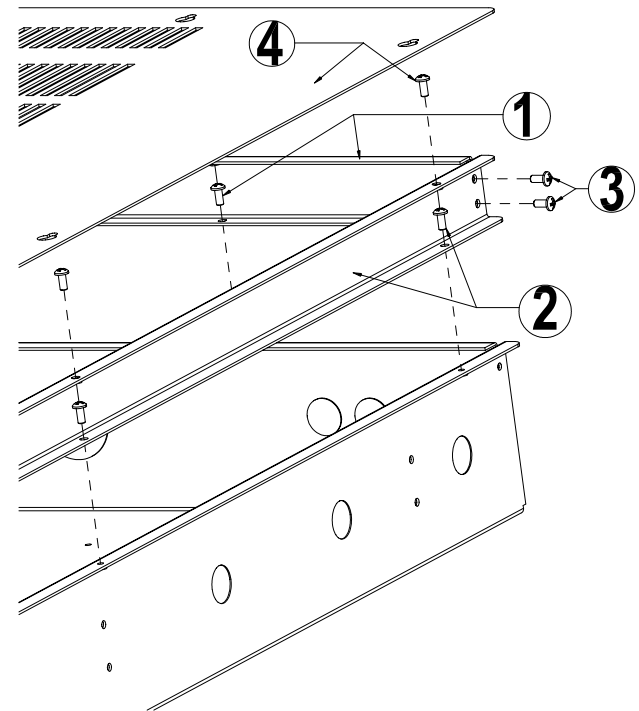

1. As shown in the installation diagram, place a horizontal pan on the bottom and top of the CAEN enclosure (**edges facing inward**). Use a #2 Phillips tip screwdriver to secure the horizontal pans to the enclosure using the 8-32 screws.

- As shown in the installation diagram, place two vertical brackets on the right side and two vertical brackets on the left side of the CAEN enclosure (**edges facing outward**). Use a #2 Phillips tip screwdriver and the 8-32 screws to loosely attach the vertical brackets to the enclosure.
- Secure the vertical brackets to the secured horizontal pans with a #2 Phillips tip screwdriver and the 8-32 screws. Tighten the screws holding the vertical brackets to the CAEN enclosure.
- After installing the required devices, use the remaining screws to install the CAEN cover.

Further Inquiries

If you cannot locate specific information or have questions after reviewing this guide, please take advantage of Crestron's award winning customer service team by calling the Crestron corporate headquarters at 1-888-CRESTRON [1-888-273-7876]. For assistance in your local time zone, refer to the Crestron website (www.crestron.com) for a listing of Crestron worldwide offices.

Return and Warranty Policies

Merchandise Returns / Repair Service

- No merchandise may be returned for credit, exchange, or service without prior authorization from CRESTRON. To obtain warranty service for CRESTRON products, contact the factory and request an RMA (Return Merchandise Authorization) number. Enclose a note specifying the nature of the problem, name and phone number of contact person, RMA number, and return address.
- Products may be returned for credit, exchange, or service with a CRESTRON Return Merchandise Authorization (RMA) number. Authorized returns must be shipped freight prepaid to CRESTRON, 6 Volvo Drive, Rockleigh, N.J., or its authorized subsidiaries, with RMA number clearly marked on the outside of all cartons. Shipments arriving freight collect or without an RMA number shall be subject to refusal. CRESTRON reserves the right in its sole and absolute discretion to charge a 15% restocking fee, plus shipping costs, on any products returned with an RMA.
- Return freight charges following repair of items under warranty shall be paid by CRESTRON, shipping by standard ground carrier. In the event repairs are found to be non-warranty, return freight costs shall be paid by the purchaser.

CRESTRON Limited Warranty

CRESTRON ELECTRONICS, Inc. warrants its products to be free from manufacturing defects in materials and workmanship under normal use for a period of three (3) years from the date of purchase from CRESTRON, with the following exceptions: disk drives and any other moving or rotating mechanical parts, pan/tilt heads and power supplies are covered for a period of one (1) year; touchscreen display and overlay components are covered for 90 days; batteries and incandescent lamps are not covered.

This warranty extends to products purchased directly from CRESTRON or an authorized CRESTRON dealer. Purchasers should inquire of the dealer regarding the nature and extent of the dealer's warranty, if any.

CRESTRON shall not be liable to honor the terms of this warranty if the product has been used in any application other than that for which it was intended, or if it has been subjected to misuse, accidental damage, modification, or improper installation procedures. Furthermore, this warranty does not cover any product that has had the serial number altered, defaced, or removed.

This warranty shall be the sole and exclusive remedy to the original purchaser. In no event shall CRESTRON be liable for incidental or consequential damages of any kind (property or economic damages inclusive) arising from the sale or use of this equipment. CRESTRON is not liable for any claim made by a third party or made by the purchaser for a third party.

CRESTRON shall, at its option, repair or replace any product found defective, without charge for parts or labor. Repaired or replaced equipment and parts supplied under this warranty shall be covered only by the unexpired portion of the warranty.

Except as expressly set forth in this warranty, CRESTRON makes no other warranties, expressed or implied, nor authorizes any other party to offer any warranty, including any implied warranties of merchantability or fitness for a particular purpose. Any implied warranties that may be imposed by law are limited to the terms of this limited warranty. This warranty statement supercedes all previous warranties.

Trademark Information

All brand names, product names, and trademarks are the sole property of their respective owners. Windows is a registered trademark of Microsoft Corporation. Windows95/98/Me/XP and WindowsNT/2000 are trademarks of Microsoft Corporation.